

THE DESIGN OF AN IRRADIATION FACILITY FOR THE DESTRUCTION OF  
SPENT NITROCELLULOSE PLASTIC EXPLOSIVES - DÉSIGN D'UNE  
INSTALLATION POUR DÉTRUIRE PAR IRRADIATION LES EXPLOSIFS  
PLASTIQUES FAIT EN NITROCELLULOSE ÉPUISEE

**J.O.A. Kim, M. L'Italien, P. Nault, C. Prechotko**

Department of Chemistry and Chemical Engineering  
Royal Military College of Canada/Collège militaire royal du Canada  
P.O. Box 17000; Station Forces  
Kingston, Ontario, Canada K7K 7B4

ABSTRACT

Nitrocellulose samples were irradiated in the SLOWPOKE-2 reactor to determine the required dose to lower the nitrogen content from 13% to 11%. That weight content of nitrogen in nitrocellulose permits recycling of nitrocellulose while neutralising the explosive characteristics of the polymer. The lowering of the nitrogen content was determined using a Nicolet FT-IR. The lowering of the areas under the peaks corresponding to the NO<sub>2</sub> groups were measured and related to the content of nitrogen in the molecule. That enabled us to estimate the dose required to lower the nitrogen content in the nitrocellulose. A facility capable of delivering 1.85 kGy of gamma irradiation to the spent nitrocellulose propellant was designed, using Cobalt-60, a radioisotope that decays through emission of gamma photons. The facility design incorporated a batch process, which irradiated twelve nitrocellulose filled aluminum tote boxes per batch. The tote boxes were designed to be of 52cm x 50cm x 20cm (length, height, thickness) in dimensions, and were optimized in geometry for high dose uniformity and low cycle time. The facility incorporated radiation shielding to protect the surrounding environment and personnel from the harmful gamma radiation emitted during irradiation processing, including an above ground concrete enclosure, and a underground water filled pool. With a total source activity of  $3.70 \times 10^{15}$  Bq, the facility would be able to process  $8.58 \times 10^3$  metric tons of nitrocellulose per year.

I. LA NITROCELLULOSE

A. Synthétisation de la nitrocellulose

La nitrocellulose est produite de plusieurs façons. La plus courante est de la synthétiser à l'aide d'hémicellulose, qui est trouvée dans le bois naturel, et avec de l'acide nitrique (HNO<sub>3</sub>) et de l'Acide sulfurique (H<sub>2</sub>SO<sub>4</sub>). La molécule de cellulose n'a que trois sites où la nitratisation est possible. Par conséquent, la fraction massique maximale d'azote à l'intérieur de la molécule de nitrocellulose est de 14,14%.

## B. Usages civils de la nitrocellulose

La nitrocellulose a plusieurs applications. Elle peut être utilisée dans les industries de peintures, de laques et dans l'industrie des cartouches sportives [1]. En général, pour ces applications, on utilise de la nitrocellulose qui a une teneur en azote entre 10,9% et 12,0%.

## C. Usage militaire de la nitrocellulose

Le premier usage historique de la nitrocellulose a été pour la fabrication de poudres à canon. Cet usage découle du fait que la nitrocellulose qui a une teneur en azote de plus de 12,0% possède des caractéristiques explosives très intéressantes pour des applications militaires. En effet, la nitrocellulose à teneur d'azote élevée possède une très haute énergie de combustion, alors qu'elle est facile à produire et à entreposer. La nitrocellulose fait encore partie de plusieurs propergols militaires à ce jour dans les Forces canadiennes.

### 1. Problèmes associés à l'usage militaire de la nitrocellulose

La nitrocellulose à teneur élevée en azote est très instable. Si la poudre n'est pas mouillée, la nitrocellulose peut devenir explosive à la moindre étincelle. Lorsque la nitrocellulose à teneur élevée en azote est produite à des fins militaires, on y ajoute des additifs afin de stabiliser la molécule et pour avoir les qualités explosives recherchées. Après un nombre d'années déterminés, la nitrocellulose devient périmée, et elle doit être détruite.

## D. Méthodes actuelles de destruction de la nitrocellulose

Plusieurs méthodes de destruction de la nitrocellulose périmée existent. La méthode couramment utilisée dans les Forces canadiennes est la combustion à ciel ouvert. Plusieurs problèmes existent avec cette méthode. Premièrement, la combustion de la nitrocellulose produit des gaz toxiques à l'environnement, tel le  $\text{NO}_x$  et le  $\text{CO}_2$ . Deuxièmement, le transport de la nitrocellulose pose un autre problème, car les explosifs deviennent moins stables avec l'âge, et un accident de la route pourrait avoir des conséquences dangereuses. Une autre méthode envisagée par les Forces canadiennes est la combustion de la nitrocellulose périmée dans un four. Cette méthode est avantageuse parce que tous les produits de la combustion sont recyclés et traités, donc l'environnement est protégé. Par contre, cette méthode est très coûteuse.

## E. Méthode proposée de destruction de la nitrocellulose périmée

La méthode que nous proposons afin de se débarrasser de la nitrocellulose périmée est l'irradiation des stocks. En effet, des expériences précédentes ont démontré que sous l'effet de radiations gamma, la teneur en azote de la nitrocellulose diminuait. Il serait donc possible d'irradier les stocks de nitrocellulose périmée afin d'abaisser leur teneur en azote, et ainsi les rendre recyclable. Cette méthode a l'avantage d'abaisser

dramatiquement les gaz toxiques émis en atmosphère, tout en trouvant un usage alternatif à la nitrocellulose.

## II. EXPÉRIENCE

### A. Méthodologie

Le but de l'expérience était de calculer la dose nécessaire pour abaisser la teneur en azote de la nitrocellulose en bas de niveau explosif, c'est-à-dire en bas de 12,0%. Pour ce faire, de la nitrocellulose mouillée à 13,1% de teneur en azote fut séparé en 40 échantillons. Il fut jugé nécessaire d'étudier l'effet du poids de l'azote sur la dénitruration par irradiation. Donc, 5 échantillons de 0,15 g et 5 échantillons de 0,3 g furent irradiés pendant 10, 15 et 30 minutes. 5 échantillons de chaque masse furent également irradiés à puissance réduite pendant 10 minutes. Les échantillons furent ensuite analysés à l'aide d'un spectrographe FT-IR, et la teneur en azote fut déduite après irradiation.

#### 1. Procédure expérimentale

Les échantillons furent pesés, puis mis en capsules et ensuite insérées dans un support spécialement conçu. Le support fut descendu dans la piscine du réacteur SLOWPOKE-II au Collège Militaire Royal du Canada, et furent laissés pendant la période de temps déterminée. Le support fut ensuite remonté à environ mi-chemin dans la piscine et laissé reposer pendant une période d'environ 48 heures, afin d'éliminer les produits radioactifs qui auraient pu se former à l'intérieur de nos échantillons. Les échantillons furent ensuite dissous dans du Tétrahydrofurane (THF) à 0,5% pour en faire l'analyse à l'aide d'un spectrographe FT-IR. Les spectres obtenus après l'analyse furent examinés à l'aide du programme d'ordinateur *Peak-fit* afin de mesurer l'aire sous la courbe de deux pics. Les pics à  $1660\text{ cm}^{-1}$  et à  $1284\text{ cm}^{-1}$  furent choisis, car ils sont représentatifs de la présence de  $\text{NO}_2$  dans la molécule. Le pic situé à  $1660\text{ cm}^{-1}$  correspond à la région d'absorption asymétrique des groupes  $\text{NO}_2$ . Cette région varie normalement entre  $1661\text{ cm}^{-1}$  et  $1499\text{ cm}^{-1}$  et dépend de la substitution et de l'insaturation du groupe  $\text{NO}_2$ . Le pic à  $1284\text{ cm}^{-1}$  quant à lui correspond à la région d'absorption symétrique des groupes  $\text{NO}_2$ . Afin de déterminer le taux de nitration dans nos échantillons irradiés, deux techniques furent utilisées. La première consiste à fabriquer une courbe de calibration en analysant plusieurs échantillons de nitrocellulose non-irradiée et de construire une courbe de calibration avec ceux-ci. La nitrocellulose non-irradiée fut diluée à différentes concentrations dans du THF et l'aire du pic représentant les groupes nitrates fut évalué. La loi de Beer-Lambert nous permet ainsi de porter en graphique l'aire du pic étudié en fonction de la concentration et de calculer le pourcentage d'azote d'un échantillon en sachant l'aire de son pic. La deuxième méthode fut de prendre plusieurs échantillons de nitrocellulose non-irradiée dissoute à un pourcentage donné (0.5% fut choisi). Une moyenne d'aire du pic des échantillons non-irradiés peut ainsi être faite et comparée avec nos échantillons irradiés pour déterminer la variation du pourcentage d'azote.

## B. Résultats

Temps (min)	Taux d'azote (%N p/r au pic à 1660 cm <sup>-1</sup> )	Taux d'azote (%N p/r au pic à 1284 cm <sup>-1</sup> )
10	7,76	9,67
15	14,28	15,08
30	9,07	7,94
10, puissance réduite	12,85	8,75

Ces résultats ont été obtenus à partir de la deuxième méthode d'analyse, c'est-à-dire celle de la comparaison avec un échantillon de 13,1% N à une concentration de 0,5% dans le THF.

## C. Discussion

En analysant les résultats, il est remarquable que le taux d'azote semble augmenter après 15 minutes d'irradiation. En se basant sur les recherches accomplies précédemment [2], il est clair que cette situation doit être causée par une défaillance dans la procédure expérimentale. Il fût donc jugé nécessaire de ne pas tenir compte de ces résultats et de se concentrer sur les résultats obtenus après 10 minutes, 30 minutes et 10 minutes à puissance réduite. En examinant ces résultats, il devient clair que l'irradiation pendant 10 minutes à intensité réduite est la dose optimale pour l'abaissement de la teneur en azote de la nitrocellulose. Par contre, une dose exacte n'a pu être déterminée, à cause de la nature trop séparée de nos résultats. Pour cette étude, nous avons donc considéré qu'une dose de 1,85 kGy serait acceptable pour rendre la nitrocellulose en état d'être recyclée, c'est-à-dire avec un taux de nitration qui serait plus bas que 12,0%.

## III. RADIOISOTOPE SELECTION

The radioisotope selected to provide the source of radiation was Cobalt-60, a radioisotope well known for its reliability as well as its safety in industrial applications such food irradiation. Cobalt-60 possesses many advantages as a source. Firstly, Cobalt-60 decays strictly through a beta and gamma decay chain that produces two gamma photons with each disintegration. The absence of neutron decay from the Cobalt-60 decay chain allows materials to be irradiated without imparting any degree of radioactivity to the processed material, and eliminates the need to store the processed products in a cooling facility in order to allow the products' imparted radioactivity to subside. Secondly, Cobalt-60 spontaneously produces two gamma photons at 1.33 and 1.17MeV with each radioactive disintegration. These two gamma photons are easily capable of passing through the nitrocellulose material and doing useful denitration work. Thirdly, with its convenient 5.24 year half life, a Cobalt-60 based irradiator would require

little or no maintenance. In fact, it is feasible that the Cobalt-60 source could remain useful for up to ten years without any extensive maintenance, depending on the tolerances of the irradiation process and the preferences of the operator. Finally, Cobalt-60 is produced in Canada, and is locally availability through suppliers such as MDS NORDION, at a reasonable cost of \$2.00 CAD/Currie. This makes Cobalt-60 based irradiation a highly economically attractive endeavour.

#### IV. COBALT-60 SOURCES

The type of Cobalt-60 source selected for use in the irradiation facility is known as the C-188 source [3]. The C-188 is comprised of a stack of Cobalt-60 pellets that are doubly encapsulated into an inner cylindrical tube made of a zircaloy as well as a corrosion resistant outer tube made of ASTM 316 stainless steel. The C-188 is a rod shaped source that stands 451.5mm tall with a 11.1mm diameter. The activity<sup>1</sup> of each C-188 source can be custom manufactured to a maximum of  $4.81 \times 10^{14}$  Bq (13 kCi).

The C-188 source was selected for a number of reasons. Firstly, being a Canadian product, the C-188's are easier to procure than foreign sources since transportation and licensing would involve only one government. As well, the C-188 was selected due to its exceptional safety record that it has achieved over the past 35 years which has consistently meet IAEA<sup>2</sup>, CSA<sup>3</sup>, and ISO<sup>4</sup> specifications.

C-188 sources are not intended for use as stand alone sources, but rather they are intended for use as the building blocks of larger gamma irradiation sources, called source racks. Common arrangements of source racks include curtain-like arrangements, where irradiated products pass on either side of the curtain, or ring arrangements, where irradiated products pass through a tunnel made of C-188 sources.

#### V. SOURCE RACK CONFIGURATION

The source rack configuration chosen was a 2 x 3 (two row by three column) arrangement of the sub-modules (Fig. 1). The 2x3 design geometry allows for simple calculation of the dose delivered to the nitrocellulose, since it can be represented as a large rectangular source that is the aggregate of the six sub-modules. The 2x3 configuration also incorporates geometric symmetry; a property which, when managed properly, allows to the operator to overcome problems of dose uniformity in the irradiated samples.

The total activity of the source rack was chosen to be  $3.70 \times 10^{15}$  Bq (100kCi), a relatively small amount of activity. The source rack's activity was chosen to be small, since nitrocellulose possesses a relatively low density (between 1.55-1.66 g/cm<sup>3</sup>), and also requires a fairly small dose to achieve proper denitration (1.85 kGy).

---

<sup>1</sup> units of activity: 1Currie (Ci) =  $3.7 \times 10^{10}$  Becquerels(Bq)

<sup>2</sup> International Atomic Energy Agency

<sup>3</sup> Canadian Standards Association

<sup>4</sup> International Organization for Standardization

## VI. TOTE CONTAINERS FOR IRRADIATION

Due to the symmetry inherent in the source rack configuration, simple rectangular totes were chosen as a means of containing the nitrocellulose during their irradiation processing. In order to maximize irradiator efficiency, it was decided to have twelve identical tote boxes, six totes on either face of the source curtain (Figure 2).

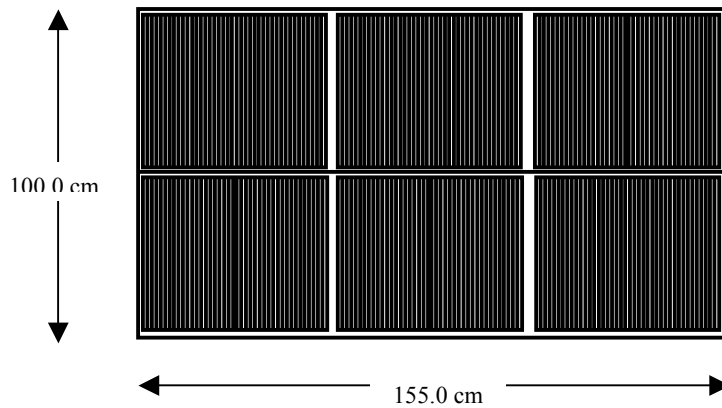

Figure 1 – The 2x3 Source Rack Design With Total Activity of  $3.70 \times 10^{15}$  Bq (100 kCi)

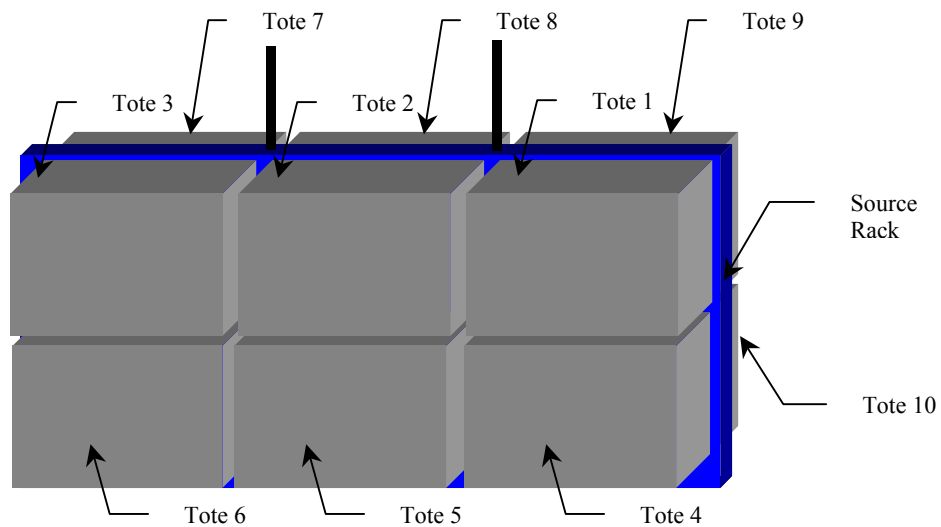
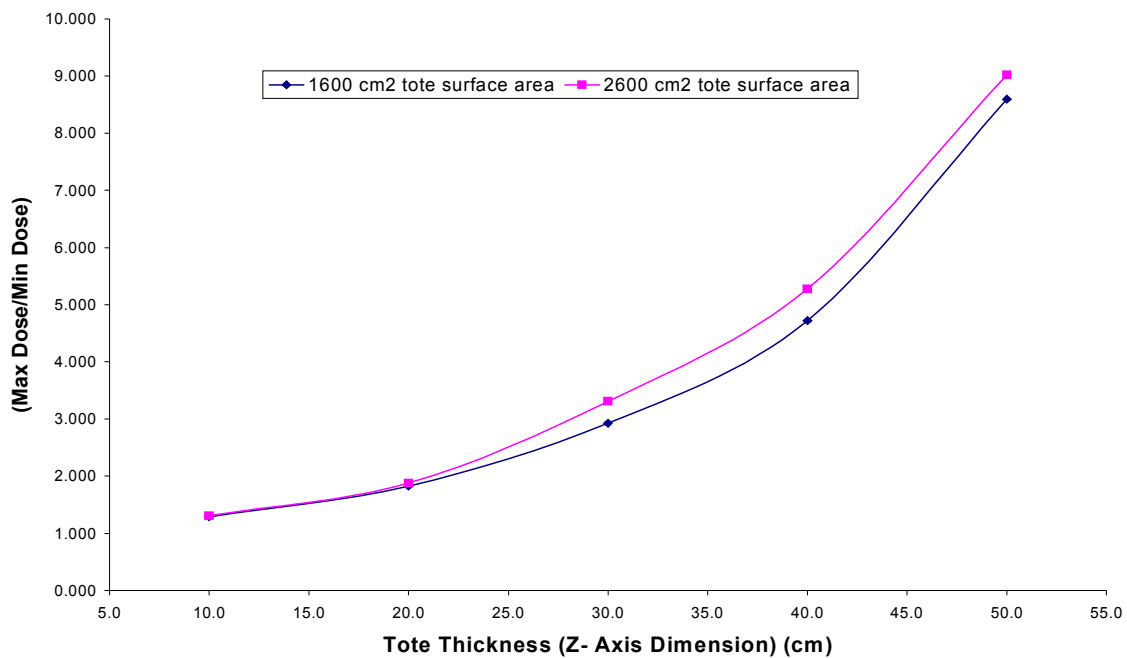

Figure 2 – Spatial Orientation of Tote Boxes With Respect to the Source Rack

Ten different tote geometries were devised and scrutinized using a series of Microshield 5™ simulations. The end goal of the tote simulations was to determine the optimum geometry to minimize the max-to-min dose ratio inside of the totes, as well as maximize processing rates. It should be noted that these dose rate simulations, using the ten tote configurations, were done in accordance with a mechanical tote interchange process where totes spend half of their irradiation time on one side of the source rack, and then are repositioned on the opposite side of the source rack for the rest of the irradiation time.

The behaviour of the ten different tote configurations in the dose rate simulations illustrated some very important trends. The first trend observed was that thinner totes corresponded to smaller max-to-min dose ratios along the z-axis of the tote. As well, the difference in the max-to-min dose rate ratio between the totes with 1600.0cm<sup>2</sup> to those with 2500.0cm<sup>2</sup> of surface area exposed to the source rack was relatively small at smaller z-axis dimensions (smaller than 25cm), see [Figure 3](#).



[Figure 3](#) – (Max/Min) Dose Ratio as a Function of Tote Thickness

At Z-axis values smaller than 20cm, the difference observed in maximum-to minimum dose ratio values between the two variant cross sections was minimal, however the corresponding difference in processing rate was of disproportionately large. For example at  $Z = 20\text{cm}$ , the max-to-min dose ratio values for the totes of cross sections of 1600cm<sup>2</sup> and 2600cm<sup>2</sup> were 1.85 and 1.88 respectively while the processing rates were  $8.58 \times 10^3$  metric tonns/yr and  $1.15 \times 10^4$  metric tonns/yr respectively ([Fig 4](#)).

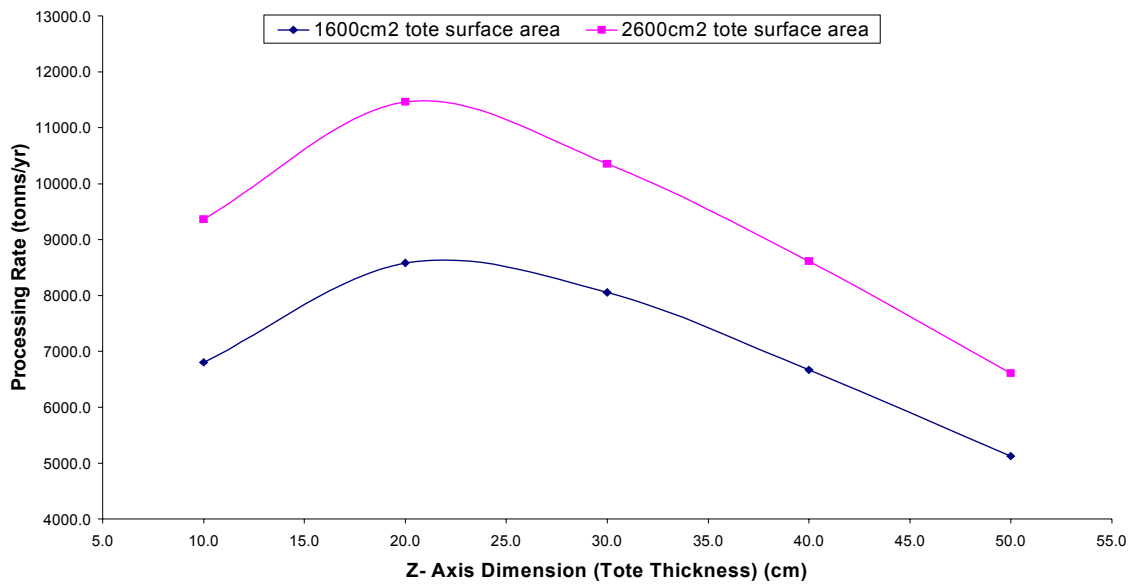

Figure 4 - Nitrocellulose Processing Rate as a Function of Tote Thickness

This large difference in processing rate has great economic repercussions that far outweigh any marginal improvement in dose uniformity. Since the irradiated nitrocellulose can be sold to manufacturers as a recyclable material, the rate at which the nitrocellulose can be processed translates into revenue rates. Therefore, since the nitrocellulose's processing rate reaches a maximum at a tote thickness near 20cm, the tote's thickness was selected to be 20cm. Thus the dimensions of each tote box was chosen to be 52 cm x 50 cm x 20 cm (X,Y,Z) respectively (fig 5)

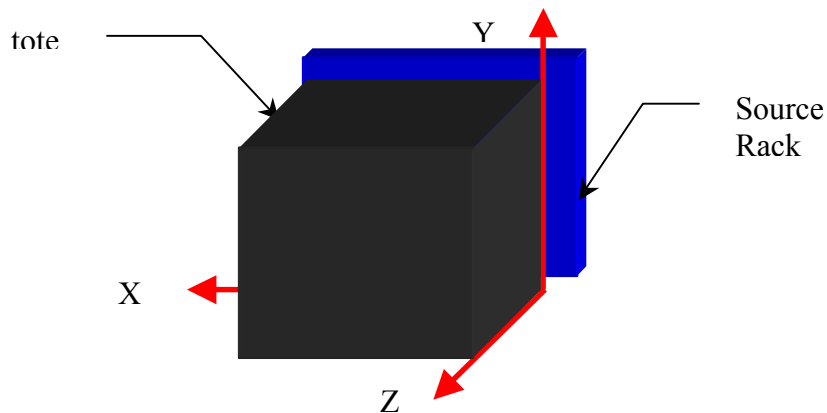

Fig. 5 – Spatial Orientation of Tote Box used in Optimization Trials



With this tote configuration, the axis containing the largest maximum-to-minimum dose ratio gradient is still the Z-axis (Fig. 5). Thus if one determined that the tote arrangement lacked the appropriate dose uniformity as per required by a nitrocellulose recycler, a decrease in the tote's Z-axis dimensions would be in order (see Fig 6 & Fig 7)

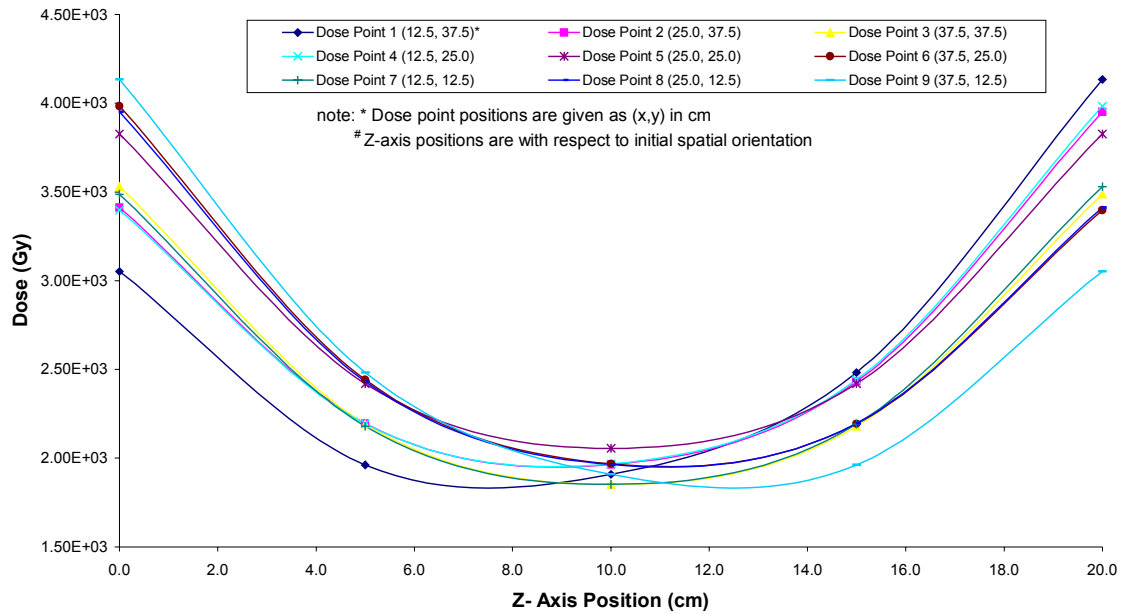

Figure 6 – Dose in tote 1 as a function of Z-axis position

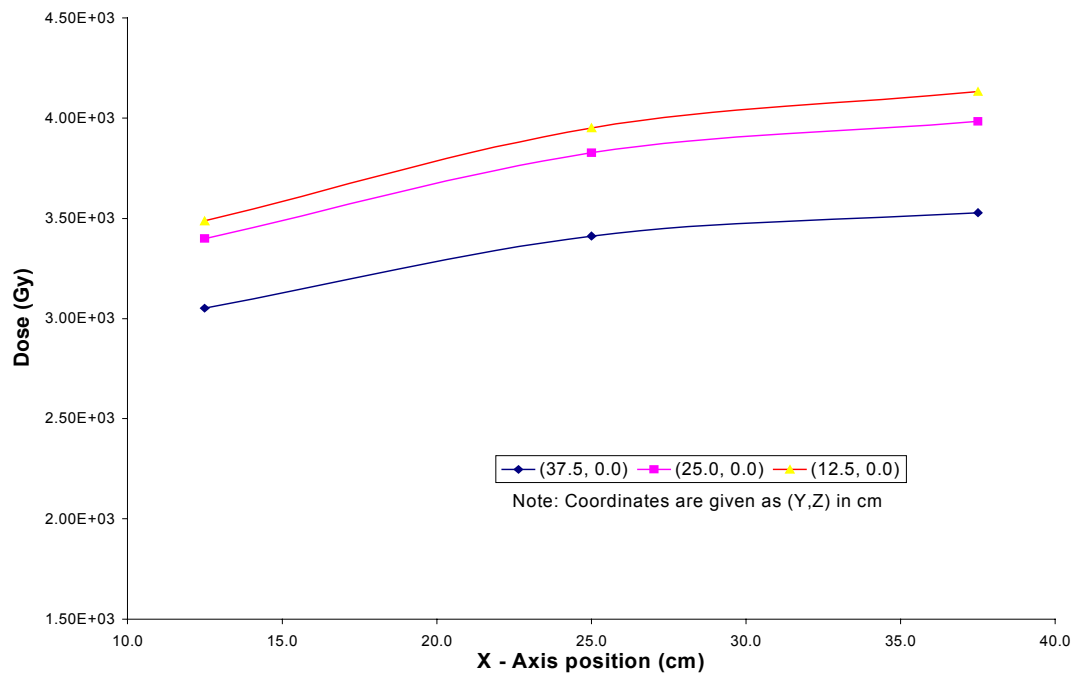

Figure 7 – Dose in Tote 1 as a function of X-axis Position

## VII. RADIATION SAFETY STANDARDS AND SHIELDING

For the design of the radiation shielding of the facility, the authors endeavored to ensure that the shielding met the civilian requirement of 5mSv/year with a ten times safety factor. Thus shielding was designed such that the maximum allowable dose received by an individual standing directly outside of the shielding enclosure for the entire year would not exceed 0.5mSv. Shielding was thus built for a  $1.480 \times 10^{16}$  Bq (400 kCi) source.

Since the irradiator would operate as a batch process, shielding had to be designed such that no gamma radiation exposure could possibly occur when the batch's totes are being exchanged at the beginning and end of each cycle. In order to accomplish this, the source rack as well as a small section of the containment shielding was chosen to be a moveable. The movement of the source rack, at the beginning and end of each batch, thus called for the design of two sets of shields: one for when irradiation is occurring, and another for when the irradiator is not in use or undergoing source rack maintenance. The simplest shielding solution for our facility would be an above ground/underground combination enclosure (Fig. 8 & Fig.9) to provide shielding for when the irradiator is in use, and when it is not in use. The centerpiece of the shielding arrangement would be an open air, water filled pool.

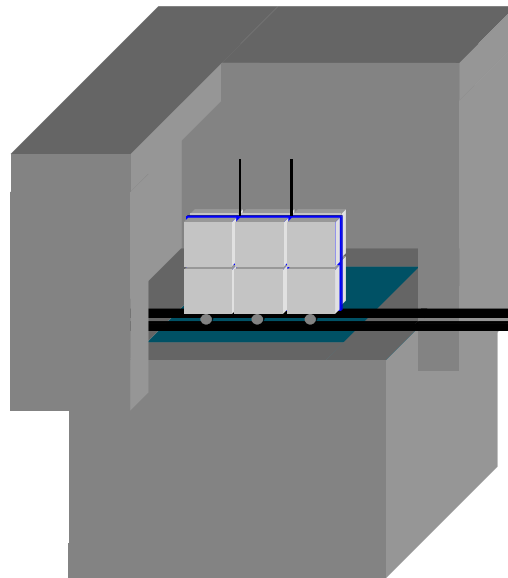

Figure 8 Cutaway View of Above Ground & Pool Shielding Enclosures With Tote Boxes, Source Rack, and Mobile Section of Shielding Enclosure In Operating Positions

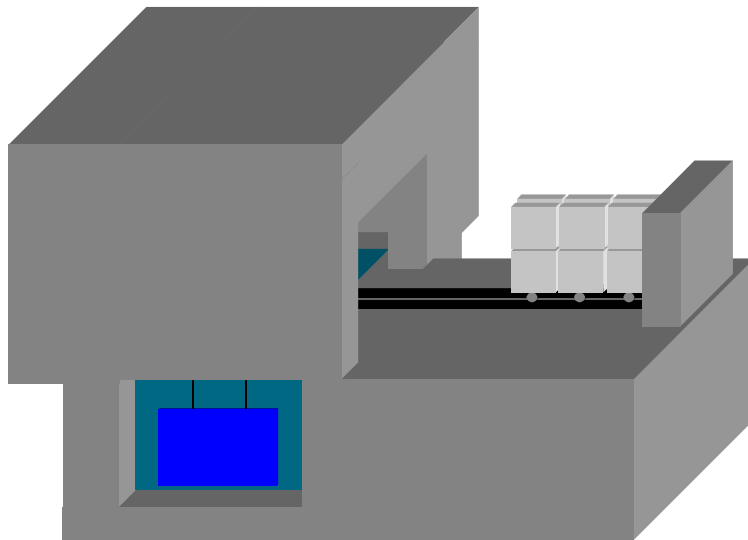

Figure 9 – Above Ground & Pool Shielding Enclosures with Tote Boxes, Source Rack, and Mobile Section Of Shielding Enclosure In the Load/Unload Position

The movement of the mobile section of the facility's shielding and the tote boxes, would be accomplished through the use of a system of rails. This would also allow access into the irradiation inclosure at the beginning and end of each batch of irradiation processing.

The dimensions and specifications and schematics of each of the shielding enclosure's components were determined using a series of Microshield 5™ calculations, and were omitted from this paper for the sake of brevity.

## VIII. PROCESS QUALITY INSURANCE THROUGH USE OF DOSIMETERS

The verification of dose uniformity and the quality of the irradiation processing during the operation of the facility needs to be performed on the outgoing processed materials, especially if the processed material were to be sold as recyclable materials.

An alternative to FTIR testing to determine the level of denitration would be to use commercially available Polymethylmethacrylate (PMMA) dosimeters. Dosimeter manufacturers, such as Harwell Ltd. who manufactures the Perspex™ line of dosimeters, provide calibration curves which relate the irradiation doses as a function specific absorbance. Thus in order to determine the degree of denitration achieved during processing, a calibraion curve would need to prepared which relates the degree of denitration to dose. With this done, the determination of the level of denitration would be

a matter of taking a simple specific absorbance reading (using a spectrophotometer) of a dosimeter that was in the same tote as the nitrocellulose of interest. It should be noted that the dosimeter method of quality assurance would offer a considerable cost advantage to the operators of the facility, as it significantly reduces the need for costly FTIR testing.

## IX. SOURCE ACTIVITY DECAY & IRRADIATION PERIODS

The total activity of the source rack decreases as a function of time. This has practical implication on the operation of the facility. In order to compensate for this loss of activity, the users of the irradiator would need to increase the period of irradiation at regular intervals. Although recalculating the ideal irradiation period each day, or for each batch would be a simple task, implementing those changes on the production line would be somewhat more difficult a task. With each change in the batch irradiation period, facility workers must change the rhythm and intensity of work, thus increasing the risk of workplace accidents or mistakes. It is thus suggested that the period of irradiation be set and changed on a monthly basis, beginning the month with the irradiation period that is ideal for the last day of the month in question.

The effect of the decrease in total source activity on the quality of the irradiation processing was also investigated. Five Simulations were performed in Microshield 5™, in order to determine the effects of decreased source activity on the max-to-min dose ratio inside of the tote boxes. It was found that the max-to-min dose ratio increases by small values as a function of time (Fig. 10). The replacement schedule of the source rack will thus be a function of the range of nitrogen content that is considered acceptable for recycling purposes, since the larger the max-to-min dose ratio, the larger the range of nitrogen content of the nitrocellulose inside of the tote box.

A simple manner of increasing the dose uniformity, while not having to replace the entire source rack would be to use totes of smaller surface area, such as a tote which has a surface tote surface area of 1600cm<sup>2</sup> as opposed to 2600cm<sup>2</sup>. By switching to a smaller tote, the edge effects of the source become less important a factor on dose uniformity, thus the max-to-min dose ratios improve slightly.

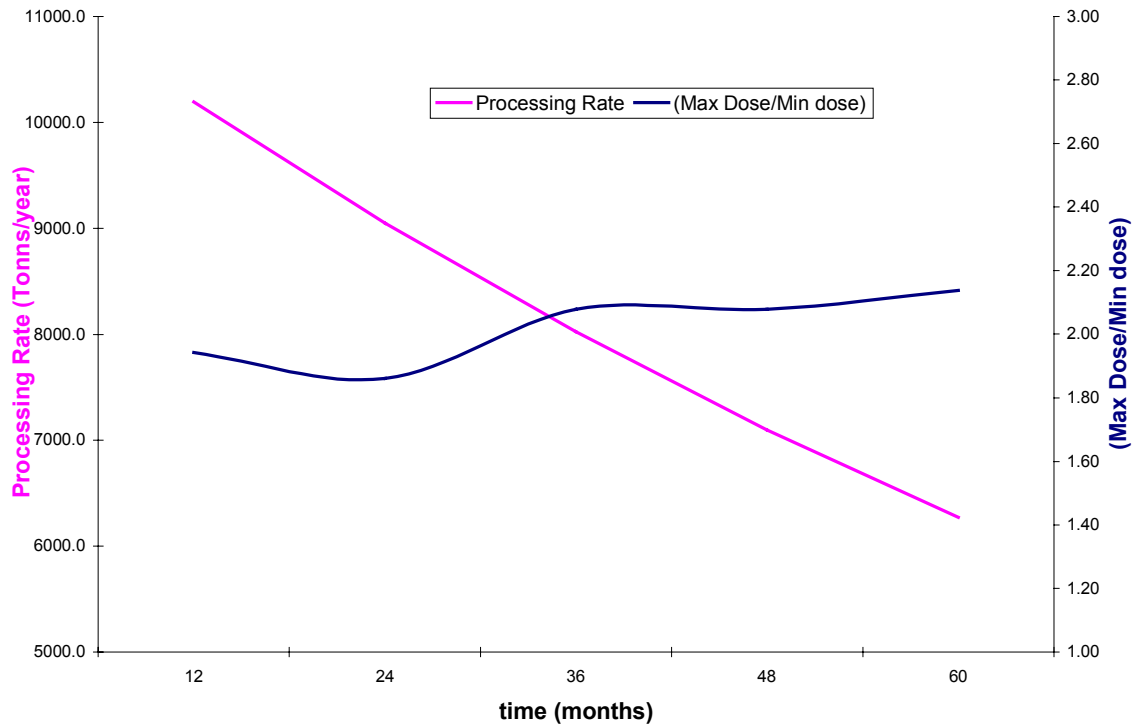

Figure 10 – Processing Rate and Max-to-Min Dose Ratio As a Function of Time

Note: Tabular forms of this data is found in Appendix B

## X. DISCUSSION

### A. Systematic Uncertainties Associated With Tote Optimization & Design In Microshield 5<sup>TM</sup>

The use of Microshield 5<sup>TM</sup> as a means to determine the dose received by the nitrocellulose inside of the tote boxes presents several sources of systematic uncertainties.

The primary purpose of Microshield 5<sup>TM</sup> is to design radiation shielding and to “estimate exposure from gamma radiation”[5] to people and materials beyond that shielding. Microshield 5<sup>TM</sup> does not allow for calculations of dose points immersed inside of objects, such as the doses of radiation received inside our tote boxes. The simulation of the nitrocellulose inside the tote box was thus achieved by creating a custom shielding material (composed of nitrocellulose), creating two shields (one made of aluminium in order to represent the tote box wall, and the other made of nitrocellulose), and placing the dose point directly behind the nitrocellulose shield. The thickness of the nitrocellulose shield was made to be equivalent to Z-axis position of the dose point inside the box. Thus in order to determine the dosimetry of the tote’s entire thickness, the size of the nitrocellulose shield was incrementally increased in 5 cm intervals until the entire thickness of the box was represented.

The systematic uncertainty for the dose values calculated using Microshield 5<sup>TM</sup> stem from the inability of the program to “represent back-scatter from materials immediately

beyond the dose point" [4]. The size of this systematic error can not be accurately determined using Microshield 5™ alone, but one would need to conduct physical experiments with case geometries, materials, and dimensions similar to those of our facility. The difference between the actual doses received and those computed using the Microshield™ method would constitute the exact magnitude of the uncertainty.

Although the magnitude of the uncertainty in the doses received in the nitrocellulose cannot be calculated without further experimental lab work, the order of magnitude of the uncertainty associated with gamma photon back-scattering is known to be in the order of 12 to 15 percent [4] for applications not unlike this facility. Thus the actual dose received in the totes would be 12 to 15 percent larger than those calculated using Microshield 5™.

In addition to the last form of uncertainty discussed, Microshield 5™ itself has its own level of uncertainty associated with all of its calculations. The magnitude of the program's uncertainty is "known to be within 10 to 15% of the true situation"[4]. This range of uncertainties applies to all of the dose point exposure rates, and the values calculated as a function of those values including: the cycle times, processing rates, exposure rates, and the max-to-min dose ratios.

The last source of uncertainty stems from the source rack geometry that was used in the Microshield 5™ simulations. Microshield 5™ does not allow for more than one source in the calculation of doses at a given dose point. Although in reality, the source rack would be a composed of some 240 C-188 sources, it is not possible to simulate for each individual C-188 source, thus a single rectangular source of dimensions 155 cm x 100cm x 1.11 cm (x,y,z) was made in order to represent the entire source rack and all of the C-188 sources. This approximation imparts uncertainties as large as large as -15.9%, where the rectangular geometry gives rise to a dose rate that is larger in magnitude in the dose that would result from cylindrical geometry. Thus the real dose rates at the dose points in the nitrocellulose filled totes would be smaller than their values calculated using the Microshield 5™ simulations.

## B. Production of Ions, Gases, and Heat During Facility Operation

Two gaseous products, NO<sub>2</sub> and O<sub>3</sub>, would be produced as a result of interaction of the gamma photons with the nitrocellulose and surrounding air. These products would need to be managed through proper ventilation of the facility or perhaps, in the case of NO<sub>2</sub>, captured for recycling purposes.

The water filled pool shield for the source rack would also need to be protected from the build-up of ions. This would serve to protect the C-188 sources from corrosion, among other things. The simplest manner in which to achieve ion-free water in the pool would be to cycle the pool's water through ion-exchange resins.

The source would also produce heat, which would need to be removed from the above ground shielding enclosure during irradiation as well as from the pool when the

source is in storage. The magnitude of the heat produced by Cobalt-60 decay is known to be  $1.54 \times 10^{-2}$  watts per curie, thus our source rack would produce a maximum of  $1.54 \times 10^3$  watts of heat energy. This heat removal could be achieved through ventilation or heat exchangers.

### C. Computer Controls & Instrumentation

Computer controls and instrumentation would be required to control the the mechanical interchange of the tote boxes, as well as the raising and lowering of the source. Computer controls and instrumentation would offer a safety advantage over manual operation of the facility, as specific safety precautions, protocols, and procedures for irradiation cycles could be programmed and executed flawlessly. This, however, is beyond the scope of this project and it would most likely be subject to work by a computer engineer.

## XI. CONCLUSIONS

1. Le pourcentage d'azote dans la nitrocellulose diminue clairement avec l'irradiation
2. Une dose d'environ 1,85 kGy serait nécessaire pour abaisser le taux d'azote dans la nitrocellulose de la façon désirée.
3. The Canadian Forces surplus of nitrocellulose does not validate the need to build such a facility, however, the Canadian Forces could build such a facility to process all of NATO's spent nitrocellulose propellant. By selling excess irradiator time and the processed nitrocellulose to industry, such a facility could become a very profitable investment. This facility's design should be brought to the attention of the Canadian Forces for review and consideration at an official level, as a means of disposing future Canadian and International stocks of spent nitrocellulose.
4. Des expériences plus approfondies sur la nitrocellulose seraient nécessaires afin de déterminer plus précisément la dose nécessaire.
5. Des expériences sur l'irradiation des autres constituants des propergols seraient nécessaires avant de pouvoir mettre le projet en oeuvre.
6. A computer code which accounts for back-scattering effects from material beyond the dose point should be created, in order to properly determine the dose rates of irradiation at the dose points inside of the tote box.

## References

1. Grandou P. et Pastour P., *Peintures et Vernis*, Hermann, Paris, p.247-253
2. Capt Heppel-Masys, *Effet des radiations gamma, des électrons et des neutrons sur la nitrocellulose*
3. MDS Nordion. *Cobalt-60 C-188 Sources – Product Information*. Nordion Marketing Comm. # 94243
4. Lamarre, G.B. Bonin, H.W. *Experimental and Computational Determination of Radiation Dose Rates In The SLOWPOKE-2 Research Reactor at The Royal Military College of Canada*. Kingston, Ontario: The Department of Chemistry and Chemical Engineering, 1999.
5. *Microshield Version 5 – Users Manual*. Rockville, Maryland: Grove Engineering, 1998. Pp. 1-5