

TECHNICAL REPORTS SERIES NO. 407

Heavy Water Reactors: Status and Projected Development



INTERNATIONAL ATOMIC ENERGY AGENCY, VIENNA, 2002

HEAVY WATER REACTORS:
STATUS AND PROJECTED
DEVELOPMENT

The following States are Members of the International Atomic Energy Agency:

AFGHANISTAN	GREECE	PARAGUAY
ALBANIA	GUATEMALA	PERU
ALGERIA	HAITI	PHILIPPINES
ANGOLA	HOLY SEE	POLAND
ARGENTINA	HUNGARY	PORTUGAL
ARMENIA	ICELAND	QATAR
AUSTRALIA	INDIA	REPUBLIC OF MOLDOVA
AUSTRIA	INDONESIA	ROMANIA
AZERBAIJAN	IRAN, ISLAMIC REPUBLIC OF	RUSSIAN FEDERATION
BANGLADESH	IRAQ	SAUDI ARABIA
BELARUS	IRELAND	SENEGAL
BELGIUM	ISRAEL	SIERRA LEONE
BENIN	ITALY	SINGAPORE
BOLIVIA	JAMAICA	SLOVAKIA
BOSNIA AND HERZEGOVINA	JAPAN	SLOVENIA
BRAZIL	JORDAN	SOUTH AFRICA
BULGARIA	KAZAKHSTAN	SPAIN
BURKINA FASO	KENYA	SRI LANKA
CAMBODIA	KOREA, REPUBLIC OF	SUDAN
CAMEROON	KUWAIT	SWEDEN
CANADA	LATVIA	SWITZERLAND
CENTRAL AFRICAN REPUBLIC	LEBANON	SYRIAN ARAB REPUBLIC
CHILE	LIBERIA	TAJKISTAN
CHINA	LIBYAN ARAB JAMAHIRIYA	THAILAND
COLOMBIA	LIECHTENSTEIN	THE FORMER YUGOSLAV REPUBLIC OF MACEDONIA
COSTA RICA	LITHUANIA	TUNISIA
CÔTE D'IVOIRE	LUXEMBOURG	TURKEY
CROATIA	MADAGASCAR	UGANDA
CUBA	MALAYSIA	UKRAINE
CYPRUS	MALI	UNITED ARAB EMIRATES
CZECH REPUBLIC	MALTA	UNITED KINGDOM OF GREAT BRITAIN AND NORTHERN IRELAND
DEMOCRATIC REPUBLIC OF THE CONGO	MARSHALL ISLANDS	UNITED REPUBLIC OF TANZANIA
DENMARK	MAURITIUS	UNITED STATES OF AMERICA
DOMINICAN REPUBLIC	MEXICO	URUGUAY
ECUADOR	MONACO	UZBEKISTAN
EGYPT	MONGOLIA	VENEZUELA
EL SALVADOR	MOROCCO	VIET NAM
ESTONIA	MYANMAR	YEMEN
ETHIOPIA	NAMIBIA	YUGOSLAVIA, FEDERAL REPUBLIC OF
FINLAND	NETHERLANDS	ZAMBIA
FRANCE	NEW ZEALAND	ZIMBABWE
GABON	NICARAGUA	
GEORGIA	NIGER	
GERMANY	NIGERIA	
GHANA	NORWAY	
	PAKISTAN	
	PANAMA	

The Agency's Statute was approved on 23 October 1956 by the Conference on the Statute of the IAEA held at United Nations Headquarters, New York; it entered into force on 29 July 1957. The Headquarters of the Agency are situated in Vienna. Its principal objective is "to accelerate and enlarge the contribution of atomic energy to peace, health and prosperity throughout the world".

© IAEA, 2002

Permission to reproduce or translate the information contained in this publication may be obtained by writing to the International Atomic Energy Agency, Wagramer Strasse 5, P.O. Box 100, A-1400 Vienna, Austria.

Printed by the IAEA in Austria
April 2002
STI/DOC/010/407

TECHNICAL REPORTS SERIES No. 407

HEAVY WATER REACTORS:
STATUS AND PROJECTED
DEVELOPMENT

INTERNATIONAL ATOMIC ENERGY AGENCY
VIENNA, 2002

VIC Library Cataloguing in Publication Data

Heavy water reactors : status and projected development. — Vienna :
International Atomic Energy Agency, 2002.

p. ; 24 cm. — (Technical reports series, ISSN 0074-1914 ; no. 407)

STI/DOC/010/407

ISBN 92-0-111502-4

Includes bibliographical references.

1. Heavy water reactors I. International Atomic Energy Agency.
- II. Series: Technical reports series (International Atomic Energy Agency) ; 407.

VICL

02-00284

FOREWORD

At the beginning of 2001, heavy water reactors (HWRs) represented about 7.8% of the electricity producing reactors in terms of number and 4.7% in terms of capacity of all current operating reactors. HWR technology offers fuel flexibility, low operating costs and a high level of safety, and therefore represents an important option for countries considering nuclear power programmes.

As a result of the success gained with the development of HWR technology since the 1960s, the IAEA International Working Group on Heavy Water Reactors (IWG-HWR) recommended that details of this development be published. This report is the result of that recommendation.

The report outlines the characteristics of HWRs and provides an insight into the technology for use by specialists in countries considering nuclear programmes, as well as providing a reference for engineers and scientists working in the field, and for lecturers in nuclear technology.

The main emphasis of the report is on the important topics of economics, safety and fuel sustainability. Additionally, it describes the historical development of HWRs and provides a comprehensive review of the different national efforts made in developing varying reactor concepts and in taking them to the stage of prototype operation or commercial viability. It covers in limited detail some aspects of technology specific to HWRs, such as heavy water production technology, heavy water management and fuel channel technology. The environmental aspects of operating HWRs are addressed in one section. The last section addresses the possible future directions likely to be taken in the development of HWR technology for the three concepts that represent different national efforts.

The pressurized heavy water pressure tube reactor design as typified by the CANDU reactor is the dominant reactor technology among the heavy water concepts. As a result, most examples of the approaches and design descriptions are drawn from this technology. Input from Member States operating different designs or variants forms an integral part of the report.

The IAEA technical officer responsible for this publication was R.B. Lyon of the Division of Nuclear Power. The IAEA acknowledges, with gratitude, the efforts made by E. Price of AECL, who worked extensively with the IAEA to develop and pull together the various contributions that form this report.

EDITORIAL NOTE

Although great care has been taken to maintain the accuracy of information contained in this publication, neither the IAEA nor its Member States assume any responsibility for consequences which may arise from its use.

The use of particular designations of countries or territories does not imply any judgement by the publisher, the IAEA, as to the legal status of such countries or territories, of their authorities and institutions or of the delimitation of their boundaries.

The mention of names of specific companies or products (whether or not indicated as registered) does not imply any intention to infringe proprietary rights, nor should it be construed as an endorsement or recommendation on the part of the IAEA.

The authors are responsible for having obtained the necessary permission for the IAEA to reproduce, translate or use material from sources already protected by copyrights.

CONTENTS

1.	INTRODUCTION	1
2.	HWR EVOLUTION	2
2.1.	General background	2
2.2.	Heavy water moderated, heavy water cooled reactor	7
2.3.	Genealogy of boiling light water, heavy water moderated power reactors	12
2.4.	Heavy water moderated, organic cooled reactor	14
2.5.	Genealogy of pressure vessel HWRs	14
2.6.	Genealogy of heavy water moderated, gas cooled reactors	15
2.7.	Summary	15
3.	CHARACTERISTICS OF HWRs	16
3.1.	Pressure tube type HWR (heavy water cooled, heavy water moderated) characteristics	16
3.2.	Pressure tube boiling light water coolant, heavy water moderated reactors	55
3.3.	Characteristics of a pressure vessel PHWR	77
3.4.	Characteristics of heavy water moderated, gas cooled reactors ...	99
3.5.	Unique features of HWR technology	113
4.	ECONOMICS OF HWRs	153
4.1.	Introduction	153
4.2.	Economics of HWRs	155
4.3.	Factors influencing capital costs	155
4.4.	Factors influencing O&M costs	159
4.5.	Factors influencing fuel costs	160
4.6.	The next twenty years	160
5.	SAFETY ASPECTS OF HWRs	161
5.1.	Introduction	161
5.2.	Design characteristics of current HWRs related to safety	161
5.3.	Behaviour of current HWRs in postulated accidents	198
5.4.	Safety enhancements under way for current generation HWRs ...	256
5.5.	HWRs over the next ten years	292

5.6.	Safety enhancement options for next generation HWRs (ten to twenty years)	302
5.7.	Options beyond twenty years	309
5.8.	Conclusions	319
6.	HWR FUEL CYCLES	320
6.1.	The natural uranium fuel cycle	323
6.2.	HWR fuel cycle flexibility	371
6.3.	Advanced HWR fuel designs	381
6.4.	SEU and recycled uranium	410
6.5.	HWR/PWR synergistic fuel cycles	451
6.6.	HWR MOX with plutonium from spent HWR natural uranium fuel	492
6.7.	HWR MOX fuel for ex-weapons plutonium dispositioning	494
6.8.	Plutonium annihilation	502
6.9.	Thorium	508
6.10.	HWR/FBR synergistic fuel cycles	540
6.11.	Summary of HWR fuel cycle strategies and technology developments required	541
7.	ENVIRONMENTAL CONSIDERATIONS	546
7.1.	Introduction	546
7.2.	Status and evolution: Design and operation	548
7.3.	Future directions and improvements	568
7.4.	Conclusions	573
8.	VISION OF ADVANCED HWR DESIGNS	575
8.1.	Introduction	575
8.2.	Economic vision	577
8.3.	Safety vision	580
8.4.	Vision of sustainability	583
8.5.	Concepts under development	584
8.6.	The Indian AHWR	600
8.7.	The HWR 1000 ultimate safe gas cooled reactor	617
8.8.	The next generation of CANDU	622
8.9.	Conclusions	647

APPENDIX: PARAMETERS OF THE PRINCIPAL TYPES OF HWR . . .	649
REFERENCES	684
CONTRIBUTORS TO DRAFTING AND REVIEW	702

1. INTRODUCTION

In 1996, the 40th General Conference of the IAEA approved the establishment of a new International Working Group (IWG) on Advanced Technologies for Heavy Water Reactors (HWRs).¹ At its first meeting, held in June 1997, the IWG-HWR recommended that the IAEA prepare a technical report to present:

- The status of HWR advanced technology in the areas of economics, safety and fuel cycle flexibility and sustainable development;
- The advanced technology developments needed in the following two decades to achieve the vision of the advanced HWR.

The IAEA convened two Consultants Meetings and two Advisory Group Meetings in order to prepare the report. One of the Consultants Meetings was on Fuel Cycle Flexibility and Sustainable Development; the other was on Passive Safety Features of HWRs — Status and Projected Advances. The IWG-HWR agreed on the essential features that the development of HWRs must emphasize. These ‘drivers’ are:

- *Improved economics.* The fundamental requirement enabling all successful high technology developments to advance is real economic improvement, consistent with improved quality.
- *Enhanced safety.* In order to meet the increasingly stringent requirements of the regulatory authorities, the public and the operators, an evolutionary safety path will be followed, incorporating advanced passive safety concepts where it is feasible and sensible to do so.
- *Sustainable development.* The high neutron economy of HWRs results in a reactor that can burn natural uranium at high utilization of ²³⁵U, utilize spent fuel from other reactor types and, through various recycle strategies, including use of thorium, extend fissile fuel resources into the indefinite future.

This publication has been built around these three drivers. Thus, these topics are extensively reviewed in Sections 4, 5 and 6. Sections 2 and 3 provide an introduction into the background of HWR technology in various countries, while Section 7 addresses the important issue of environmental concerns. Section 8 discusses the projected development of the technology. The Appendix shows the national status of heavy water nuclear power plants. The objectives of this publication are to:

¹ This group has since (2001) been replaced by the Technical Working Group on Advanced Technologies for Heavy Water Reactors (TWG-HWR).

- Present the status of HWR technology;
- Document the safety characteristics of current HWR designs and the potential enhancements;
- Present a ‘vision’ of the long term development of the HWR, for use into this century, as an electricity source that is sustainable and flexible and which retains a low cost operational condition;
- Illustrate the short and medium term potential for design evolution of the heavy water type reactor;
- Describe the basis of the economic competitiveness of the HWR, its resistance to severe cost increases and the capability for extensive source localization;
- Provide a reference publication on HWRs and help guide the activities of the IWG-HWR.

Those organizations developing and operating HWRs recognize the potential for development of this line of reactors, and it is the intent of this report to illustrate that potential. Various countries and organizations have, in the past, explored a number of variants of HWRs and there is a desire to continue to explore some of these options in the future. Currently, the pressurized heavy water cooled, heavy water moderated design is an economically competitive one which will likely continue to dominate the heavy water type reactor for some time.

This report concentrates on heavy water moderated reactors used for electricity production. Reactors for district heating and research reactors are not discussed, except where historical multipurpose use was a rationale for developing the concept.

2. HWR EVOLUTION

2.1. GENERAL BACKGROUND

In the 1950s, having proved the feasibility of producing large amounts of energy by nuclear fission in the course of operating research reactors for the production of isotopes, the use of nuclear energy for the commercial production of electricity was under development in a number of countries. This required the production of energy as heat at temperatures much higher than the coolant temperatures of the isotope production reactors. Thus, there was a need for R&D programmes to develop solutions to material, coolant and safety issues. HWR programmes were started in Canada, France, Germany, Italy, Japan, Sweden, Switzerland, the United Kingdom, the United States of America and the former USSR. Each country built research and prototype power reactors, some operating successfully for a number of years, but only the heavy

water moderated, heavy water cooled version developed in Canada proceeded to the stage of commercial implementation to become one of the three internationally competitive reactor types available at the end of the 20th century and which has been exported to a number of countries.

The development of heavy water moderated reactors followed different streams: pressure tube heavy water cooled, pressure vessel heavy water cooled, pressure tube light water cooled, pressure tube gas cooled and one pressure tube organic cooled design. Figures 1 and 2 are time charts showing the duration of concept design development, construction and operating time for each of the electricity producing heavy water designs (the data appear in Table I). The charts show quite clearly the concentration of design and construction effort in the 1960s and 1970s [1].

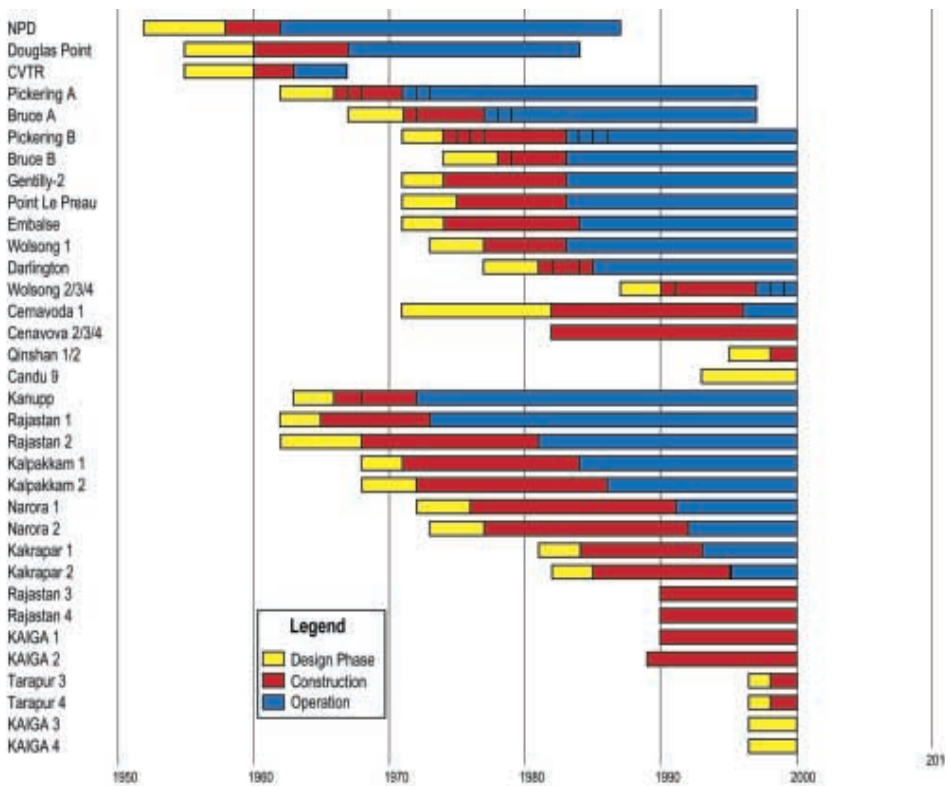

FIG. 1. Pressure tube pressurized heavy water moderated and heavy water cooled reactors.

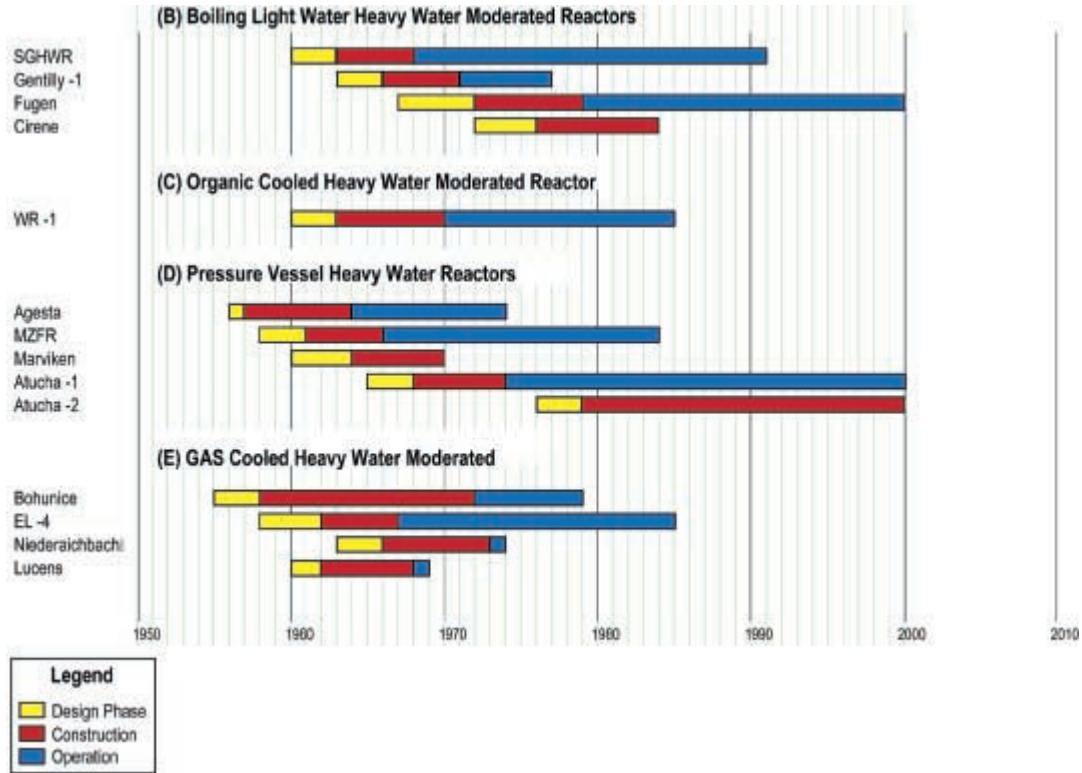

FIG. 2. Other heavy water moderated reactors.

TABLE I. DESIGN, CONSTRUCTION AND OPERATIONAL PHASES OF THE PRESSURE TUBE HEAVY WATER MODERATED HEAVY WATER COOLED REACTORS

Plant	Date of commencement of:		Date of startup/ connection to grid	Date of shutdown
	Design	Construction		
NRU	~1952	1958	1962	1987
Douglas Point	~1955	1960	1967	1984
CVTR	~1955	1960	1963	1967
Pickering A (1–4)	~1962	1966/66/67/68	1971/71/72/73	1997 ^a
Bruce A (1–4)	~1967	1971/70/72/72	1977/76/78/79	1997 ^b
Pickering B (5–8)	1971	1974/75/76/76	1983/84/85/86	
Bruce B (5–8)	1974	1978/78/79/79	1985/84/86/87	
KANUPP	1963	1966–1968	1972	
Gentilly 2	1971	1974	1983	
Point Lepreau	1971	1975	1983	
Embalse	1971	1974	1984	
Wolsong 1	1973	1977	1983	
Darlington (1–4)	1977	1982/81/84/85	1990/90/92/93	
Wolsong 2	1987	1990	1997	
Wolsong 3,4	1990	1991	1998/99	
Cernavoda 1	1971	1982	1996	
Cernavoda 2,3,4,5	1971	1982		
Qinshan 1,2	1995	1998		
CANDU 9	1993			
India				
Rajasthan 1	1962	1965	1973	
Rajasthan 2	1962	1968	1981	
Kalpakkam 1		1971	1984	
Kalpakkam 2		1972	1986	
Narora 1		1976	1991	
Narora 2		1977	1992	
Kakrapar 1		1984	1993	
Kakrapar 2		1985	1995	
Rajasthan 3		1990		
Rajasthan 4		1990		
Kaiga 1		1990		
Kaiga 2		1989		
Tarapur 3		1998		
Tarapur 4		1998		

^a Temporary shutdown. Restart scheduled for late 2002.

^b Temporary shutdown. Restart scheduled for 2003.

TABLE I. (cont.)

Plant	Date of commencement of:		Date of startup/ connection to grid	Date of shutdown
	Design	Construction		
Boiling light water heavy water moderated reactors				
SGHWR	~1960	1963	1968	1991
Gentilly 1	1963	1966	1971	1977
Fugen	1967	1972	1979	
Cirene	1972	1976/84		1988
Organic cooled heavy water moderated reactor				
WR 1	1960	1963	1970	1985
Pressure vessel heavy water reactors				
Ågesta	~1956	1957	1964	1974
MZFR	~1958	1961	1966	1984
Marviken	~1960	1964		
Atucha 1	~1965	1968	1974	
Atucha 2	~1976	1979		
Heavy water moderated gas cooled reactors				
Bohunice	~1955	1958	1972	1979
EL 4	~1958	1962	1967	1985
Niederaichbach	~1963	1966	1973	1974
Lucens	~1960	1962	1968	1969

At the beginning of 2001, 31 heavy water cooled and moderated nuclear power plants were in operation, having a total capacity of 16.5 GW(e), representing roughly 7.76% by number and 4.7% by generating capacity of all current operating reactors. One heavy water moderated, boiling light water cooled reactor was in operation. Six heavy water nuclear power plants were under construction, representing about 18.18% by number and 12.47% by generating capacity of the total units under construction [2]. In total, more than 745 reactor-years of HWR operating experience has been accumulated.

2.2. HEAVY WATER MODERATED, HEAVY WATER COOLED REACTOR

2.2.1. Genealogy of the CANDU HWR

Development of the initial design for a heavy water moderated, heavy water cooled pressure tube reactor was principally undertaken in Canada and had its origins in the activities conducted by physics groups during the early 1940s. Canada's atomic physics programme of the 1930s had been boosted by that time by participants from wartime allied countries, particularly the UK. In Montreal, this group studied how a mixture of heavy water and uranium could sustain a chain reaction. In 1944, the group was assigned the task of developing a 10 MW HWR system, heavy water moderated, natural uranium fuelled, to be used to produce neutrons for research and isotopes, initially fissile isotopes, for weapon research [3].

The Chalk River site was chosen in 1944 for what was to become the Chalk River Laboratories. At this site, development and construction of the Canadian heavy water moderated research reactors ZEEP (1945), NRX (1947) and NRU (1957), and the development of the laboratories, took place.

With the experience it gained in heavy water reactors, Canada chose to develop the heavy water moderated power reactor that became known as CANDU. This choice made best use of Canada's experience with heavy water research reactors and, of particular importance, by putting an emphasis on neutron economy it enabled Canadian uranium to be used as reactor fuel, obviating the necessity of enriching the uranium in foreign facilities. At that time, all enrichment facilities had been built and operated primarily for military purposes.

In 1955, the first small scale prototype heavy water moderated and cooled reactor was committed as a joint undertaking by Atomic Energy of Canada Ltd (AECL), Ontario Hydro (OH (now Ontario Power Generation)) and a private sector company, Canadian General Electric (CGE). The initial design employed a pressure vessel, but in 1957 the design was changed to the pressure tube type. Named the Nuclear Power Demonstration (NPD), this reactor commenced operation in 1962, generating 25 MW of electricity. NPD was followed by the tenfold larger prototype, Douglas Point, which commenced operation in 1967. Located at what later was to become OH's Bruce Nuclear Power Development site on Lake Huron, Douglas Point, together with NPD, established the technological base necessary for the larger commercial CANDU units that followed.

Construction of the first two such commercial units marked the beginning of what currently is OH's eight unit Pickering station. These two units, with a capacity of 500 MW each, were constructed under a tripartite capital financing arrangement between OH, AECL and the Ontario Government. Prior to their completion, OH committed a further two units as a wholly OH investment. The four units came into operation during the period 1971–1973 and established an excellent early performance record.

Following the construction of the first four units of Pickering station (Pickering A), OH proceeded with the four unit Bruce A station. Its 800 MW units came into operation in the late 1970s and were followed by four additional units at Pickering (Pickering B) and at Bruce (Bruce B). The latest four unit OH station, Darlington A, started commercial operation in 1991.

Canada made two early entries into the international power reactor supply field. As a first entry, AECL assisted the Indian Department of Atomic Energy (DAE) in the construction of a 200 MW reactor of the Douglas Point type (Rajasthan 1). Following the start of construction of a sister unit (Rajasthan 2), the programme in India was continued by India alone.

The second entry was the supply to Pakistan, by CGE, of a 120 MW CANDU reactor. CGE had developed this design on the basis of its earlier work in the design of NPD. Following this successful commercial sale, CGE had hoped to expand its markets for CANDU type plants, both domestic and foreign. Despite a major effort, these hopes were not realized and CGE subsequently decided to abandon the reactor supply market and concentrate its future nuclear business on the supply of fuel and fuel handling systems for CANDU reactors.

With the withdrawal of CGE from the reactor export market, the lead role passed to AECL. In this new role, AECL inherited a CGE conceptual design for a single unit CANDU based on the Pickering design. With its power increased to over 600 MW compared with Pickering's 500 MW, this new design (CANDU 6) was adopted by Hydro Quebec for its Gentilly 2 station and by New Brunswick Power for its Point Lepreau station. AECL sold two sister units, one to Argentina (Embalse) and one to the Republic of Korea (Wolsong). These four units, when completed in the early 1980s, quickly established excellent operating histories that have continued to the present day. The four operating units have now increased to eight with the startup of one unit in Romania (Cernavoda) and three further units in the Republic of Korea.

Four further units are under construction at Cernavoda. Two units are under construction in China (Qinshan phase III, units 1 and 2).

With the successful CANDU 6 design well established, AECL developed two further CANDU designs: a smaller (450 MW) CANDU 3 and a larger CANDU 9 in the 900 MW range. Development of the CANDU 3 design was shelved in the early 1990s when the projected market for it disappeared owing to the following factors: difficulty of financing small nuclear plants, reduction in the price of natural gas, and the development of gas turbine based generating stations with increased capacity, high efficiency and short construction time. The CANDU 9, however, is under active development, building on well-proven CANDU technology and offering significant improvements in cost, construction schedule, operability and safety. The evolution of the CANDU design is illustrated graphically in Fig. 3. In the Appendix, the design parameters of the unit types operating or under construction are tabulated.

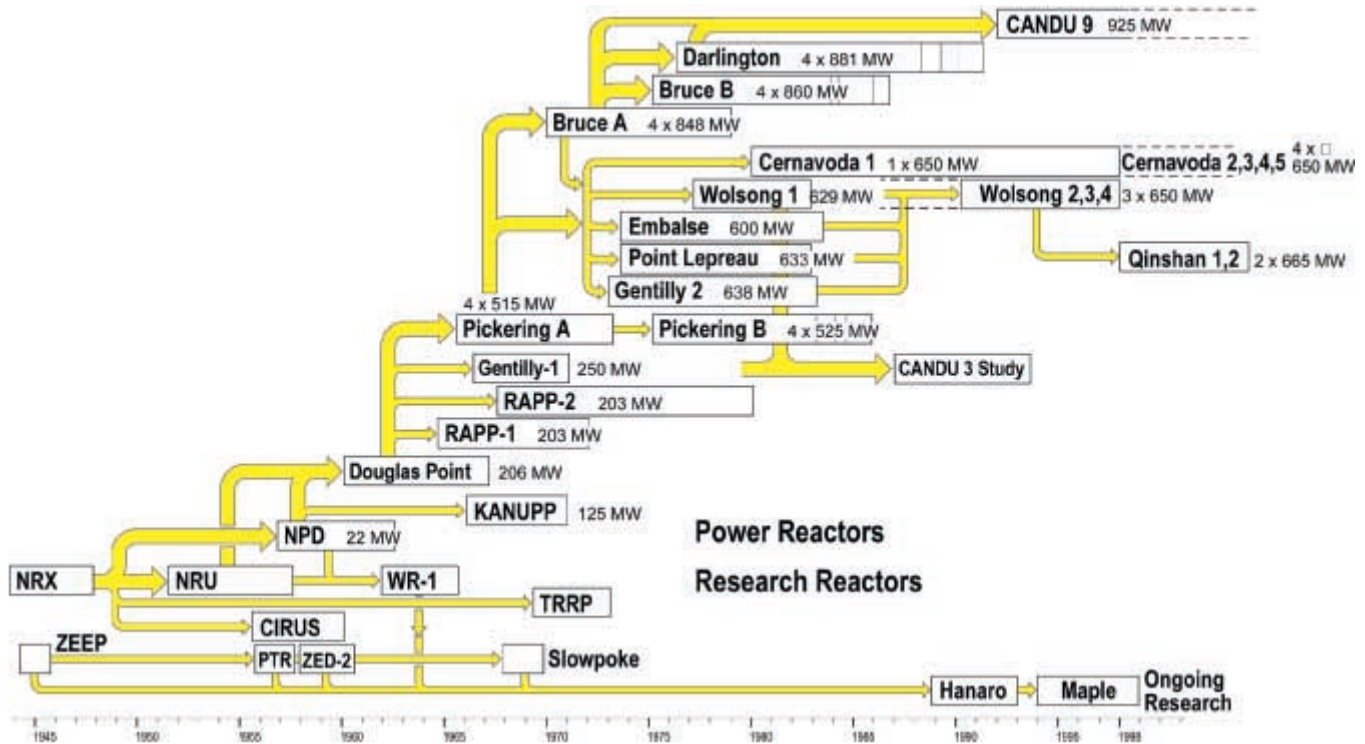

FIG. 3. Genealogy of CANDU reactors.

2.2.2. The pressure tube HWRs in India

The formulation of the long term, three stage Indian nuclear programme was based on judicious utilization of domestic reserves of uranium and abundant reserves of thorium. The emphasis of the programme was on self-reliance, with thorium utilization as a long term objective.

The three stages of the Indian nuclear power programme are:

- *Stage I:* This stage envisages construction of natural uranium fuelled, heavy water moderated and cooled pressurized heavy water reactors (PHWRs). Spent fuel from these reactors is reprocessed to obtain plutonium.
- *Stage II:* This stage envisages construction of fast breeder reactors (FBRs) fuelled by plutonium produced in Stage I. These reactors would also breed ^{233}U from thorium.
- *Stage III:* This stage would comprise power reactors using ^{233}U /thorium as fuel.

The Indian nuclear power programme commenced with the construction of the Tarapur Atomic Power Station (Tarapur 1 and 2) boiling light water reactors (BWRs) which use enriched uranium as fuel and light water as the moderator. These units were set up in 1969, on a turnkey basis, by General Electric Company (USA), essentially to 'jump start' the nuclear power programme and demonstrate the technical viability of operating them within the Indian regional grid system, which was, at that time, relatively small. Subsequently, India selected HWRs for Stage I of its nuclear power programme because of the following inherent advantages:

- The HWR uses natural uranium as fuel, which, being readily available in India, helps cut heavy investment on enrichment, which is capital intensive.
- The uranium requirement for the HWR is the lowest, and plutonium production, required for FBRs (planned for the second phase of the Indian nuclear power programme), is the highest.
- The infrastructure available in the country was suitable for undertaking the manufacture of equipment for the HWR reactor.

India started constructing pressure tube HWRs with Rajasthan 1, which started commercial operation in 1973. When AECL assistance stopped during construction of Rajasthan 2, DAE, and eventually the Nuclear Power Corporation of India Ltd (NPCIL), completed it and constructed and operate a total of eight HWR units to date, mostly 220 MW(e) units (see Appendix).

An additional six units are under construction, of which two are 500 MW(e) units, with eight more units in the planning stage (see Table I and the Appendix).

TABLE II. EVOLUTION OF PHWR TECHNOLOGY IN INDIA

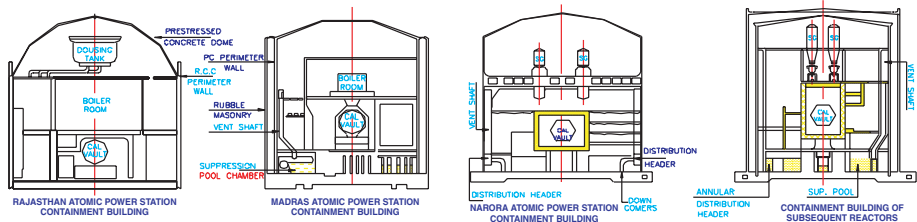

System	Rajasthan 1 and 2	Kalpakkam 1	Kalpakkam 2	Narora and Kakrapar	Kaiga, Rajasthan 3 and 4 onwards	500 MW(e)
Fuel (first charge)	19 element wire wrap			19 element split spacer graphite coated		37 element split spacer graphite coated
Pressure tube material	Rajasthan 1 to Kakrapar 1: Zircaloy 2 (Retubed in Rajasthan 2 with Zr-2.5%Nb)			Kakrapar 2 onwards: Zr-2.5%Nb		
Pressure tube manufacture	Hot extruded and cold drawn		Double pilgered			
Garter springs	Two loose fit; Rajasthan 2 retubed with four tight fit			Four loose fit up to Kakrapar 1	Kakrapar 2 onwards, four tight fit	
Pressure tube/calandria tube annulus	Air filled open			CO ₂ filled closed		
Reactor shutdown system	Moderator dumping			Shut off rods Liquid poison tube system Liquid poison addition/injection system		
Calandria and end shields	Separate			Integrated		
End shields	Carbon steel, slab type		Stainless steel, ball filled			
Calandria vault	Air filled			Water filled		
Fuelling machine	Mobile on rails			Mobile on bridge		
Primary heat transport	Single loop Eight pumps/eight steam generators			Single loop Four pumps/four steam generators		Two loops, four pumps/ four steam generators

TABLE II. (cont.)

System	Rajasthan 1 and 2	Kalpakkam 1	Kalpakkam 2	Narora and Kakrapar	Kaiga, Rajasthan 3 and 4 onwards	500 MW(e)
Primary heat transport pressure control	Feed and bleed					Pressurizer
Emergency core cooling	Injection of low pressure heavy water Fire fighting system as backup Rajasthan 2 backfitted with HPI system during retubing			High pressure heavy water injection Medium pressure light water injection Long term recirculation through suppression pool		
Pressure suppression	Dousing tank at top	Vapour suppression pool				
Containment	Single wall	Partial double wall shell, single dome		Full double wall shell, single dome	Full double containment	
Control system	Transistorized and relay logic based control system			Micro-processor based control system	Distributed microprocessor based control and operator information system	

India has progressively carried out a large number of significant improvements in the basic design (from Rajasthan 1 to Kakrapar 2 and the 500 MW(e) reactors). The evolution of the Indian PHWR programme is shown in Table II.

In parallel with the indigenous self-reliant three stage programme, India is also searching for suitable sources for the import of light water reactor technology which conforms to the latest safety standards and which is economically attractive. The recent deal with the Russian Federation for the setting up two 1000 MW(e) light water reactor units at Kudankulam is a step in this direction.

2.3. GENEALOGY OF BOILING LIGHT WATER, HEAVY WATER MODERATED POWER REACTORS

Pressure tube reactors using heavy water moderator and boiling light water coolant have been developed in three countries: Canada, UK and Japan. A fourth,

Italy, developed the Cirene reactor, which was intended to have boiling light water coolant, and although the reactor was completed, it was not started up owing to a nuclear moratorium imposed by the Italian Government [4].

In the UK, the 100 MW(e) Winfrith steam generating heavy water reactor (SGHWR) commenced operation in 1967 and was shut down in 1990. The UK authorities had decided in 1974 to adopt an upgraded commercial version of the SGHWR (650 MW(e)) for their next power station orders. However, by 1976 the decision had been reversed because of the predicted high unit cost of the commercial version combined with a forecast predicting sharply reduced demand for electricity, the need to satisfy more stringent safety criteria with design changes and the limited potential seen for export orders [5]. Despite this, the Winfrith SGHWR continued operation for a number of reasons until 1990. In common with all pressure tube reactors of this type, it had vertical pressure tubes, with boiling starting in the region of the first bundle. The reactor used enriched fuel.

In Canada, the boiling light water, heavy water reactor concept was initiated in the early 1960s and developed and put into operation as the 250 MW(e) Gentilly 1 plant in 1970. It was the only boiling light water design to use natural uranium fuel. It operated for only a short time before being shut down in 1979 [6].

In Japan, the Power Reactor and Nuclear Fuel Development Corporation (PNC) designed Fugen Advanced Test Reactor (165 MW(e)) was started up in 1978 and is still operating, having a lifetime load factor of 67% [7]. This reactor, which uses enriched fuel, was to be the prototype for a larger 600 MW(e) unit, which was intended to reuse spent light water reactor fuel. However, the need for this reactor declined with the employment of mixed oxide (MOX) fuel in the light water reactors (LWRs).

The design of the 600 MW(e) demonstration unit was based on the Fugen prototype and was effectively completed by the Electric Power Development Company (EPDC) [8]. Many of the systems and components were the same as those used in Fugen, but the number of fuel channel assemblies (648) was, naturally, higher than Fugen, and the channel power was increased by 20% by flattening the power distribution in the core. A rapid poison injection system replaced the moderator dump. In the mid-1990s, a decision was taken not to proceed with construction because the total project cost was very high.

Each of the above plants benefited from the close working relationships and collaboration existing between the design teams in Japan, UK, Italy, and Canada. The designers held regular meetings, known by the acronym JUICE (Japan, United Kingdom, Italy, Canada Exchange).

Gentilly 1 was the only light water cooled, heavy water moderated reactor to use natural uranium fuel, although the original design intent of Cirene had been to use natural uranium. The economics of this design are influenced by the power output of each channel, and usually necessitates using more channels to achieve the equivalent output of the pressurized type.

2.4. HEAVY WATER MODERATED, ORGANIC COOLED REACTOR

In 1959, AECL agreed to help fund development of a reactor concept suggested by CGE for a pressure tube heavy water moderated reactor with liquid organic coolant (CANDU-OCR) [6]. The concept partially derived from a programme for development of organic cooled and organic moderated pressure vessel reactors being pursued by General Atomics in the USA. The reactor had features similar to an HWR, with steam generators to transfer heat. The potential attractions were lower capital cost than a pressurized heavy water cooled and moderated reactor, lower coolant pressure and a higher operating temperature (higher thermal efficiency), lower heavy water leakage and minimal activity transport by the coolant. Fuelling costs with uranium dioxide fuel were higher than those for the standard HWR but were expected to be lower with the use of uranium carbide or uranium metal fuel. A 40 MW heavy water moderated, organic cooled research reactor was built at Pinawa, Manitoba (WR 1) and the concept proven.

The main operating difficulties associated with the reactor which had to be overcome were the stability of the coolant under radiation and the fire hazard associated with a leakage of coolant. The coolant was eventually run at reactor outlet temperatures as high as 425°C. Heat transfer problems from fuel to coolant were eventually solved by employing the appropriate coolant composition and chemistry, and by using uranium carbide and U₃Si fuels clad with zirconium alloy. With the feasibility proven, a design and cost study done in 1971/72 showed a 10% cost advantage in the concept. However, by this date the Pickering A reactors were operating very well and the need for an alternative concept decreased owing to a lack of utility interest. The concept was shelved, but the WR 1 reactor was operated as a research facility until 1985, when it was taken out of service.

2.5. GENEALOGY OF PRESSURE VESSEL HWRs

The first pressurized heavy water pressure vessel reactor was designed and constructed at Ågesta in Sweden by the Swedish Atomic Energy Board and ASEA [9]. It was a small reactor (65 MW), which supplied district heating and a small amount of electricity to a suburb of Stockholm. It operated from 1964 until 1975.

Following on closely from the Swedish project, a pressure vessel HWR was constructed by Siemens AG at Karlsruhe in Germany. This was the MZFR multi-purpose research reactor with an output of 57 MW(e) [10]. This reactor was intended to initiate a possible line of reactors that would not need uranium enrichment technology in order to operate. It started up in 1966 and operated successfully until 1984. Some of the output was used for the district heating of buildings at the Karlsruhe Research Centre.

On the basis of the MZFR performance, the first commercial order for a 330 MW(e) pressure vessel HWR was obtained from Argentina's Comisión Nacional de Energía Atómica (CNEA) in 1968 [11]. The new plant, Atucha 1, entered commercial operation in 1974 and has operated quite satisfactorily since, with a capacity factor near to 90% for most years, except during a major shutdown (for reactor internal repairs) in 1989–1990. Over the past few years, and up to the year 2000, a complete replacement of the 252 fuel channels has been carried out during extended, planned annual outages.

A subsequent design for a 745 MW(e) pressure vessel HWR was developed by Siemens-KWU. It was derived from the Atucha 1 design and incorporated more recent developments already used in the PWR Konvoi-1300 design produced by this company [12]. An order was then placed by CNEA in 1979 for a unit, designated Atucha 2, to be located adjacent to the previous plant. Lack of adequate funding resulted in slow construction progress until 1995, and although 80% complete, work on it has virtually stopped.

The design is claimed to be capable of increasing power output to 900–1000 MW(e) without requiring basic changes to be made to the reactor vessel.

A boiling heavy water pressure vessel reactor was designed and constructed at Marviken in Sweden; the project starting in 1960. However, it was not started up and the project was terminated in 1969 [13].

2.6. GENEALOGY OF HEAVY WATER MODERATED, GAS COOLED REACTORS

The line of heavy water moderated gas cooled reactors has been the subject of concept evaluation in a number of countries, and small electricity producing reactors have been built and operated in three countries. In France, the EL 4, which incorporated a pressure tube design, was started up in 1967 and operated until 1985 [14]. The reactor coolant was CO₂.

In Germany, the Niederaichbach reactor was a design that used pressure tubes and gas coolant (CO₂) with heavy water moderation. It had a net output of 100 MW(e) and only operated for a short time (~18 months) between 1973 and 1974 [15].

A 150 MW, CO₂ cooled, natural uranium fuelled heavy water moderated reactor of Russian design was built at the Bohunice A1 plant in Slovakia and started operation in 1973. In 1977, the reactor suffered an accident which resulted in fuel melting, after which the reactor was taken out of service [16].

2.7. SUMMARY

The pressure tube heavy water moderated, heavy water cooled reactor has been by far the most successful reactor of the heavy water type used for electricity

production. However, future development of heavy water moderated reactors is not confined to reactors of this type.

The pressure tube heavy water cooled design will be evolved into reactors with more economic features, as is the case with a line of 600–700 MW reactors termed the CANDU 6E. A further line of reactors evolved from the Bruce B/Darlington integrated designs is the single unit CANDU 9 (900–1000 MW). This design has been completed and is available for construction. Further conceptual designs evolving from the current CANDU 9 and which use slightly enriched fuel or more channels can, with only limited design changes, produce reactors with outputs of 1200 MW or 1500 MW respectively. The twenty year evolutionary path taken by the CANDU design is currently moving towards a supercritical coolant design which employs high temperature light water to increase thermodynamic efficiency and reduce capital cost (see Section 8).

The boiling light water design is being developed in India for the advanced heavy water reactor (AHWR) design with enhanced passive features and which is capable of using thorium based and recycled fuel.

The gas cooled heavy water design used for Bohunice is the basis of an ultrasafe reactor conceptual design developed by the Russian Institute of Theoretical and Experimental Physics (ITEP) in conjunction with other Russian organizations. The reactor would have a 1000 MW output and use a vessel of prestressed concrete.

At present, the following countries have active heavy water power reactor programmes: Argentina, Canada, China, India, Japan, Pakistan and Romania (see the reference table in the Appendix).

3. CHARACTERISTICS OF HWRs

3.1. PRESSURE TUBE TYPE HWR (HEAVY WATER COOLED, HEAVY WATER MODERATED) CHARACTERISTICS

3.1.1. Introduction

The dominant type of HWR is the heavy water cooled, heavy water moderated pressure tube reactor as defined for the CANDU HWR and the Indian HWRs. This type of reactor is designed to use natural uranium, but it can also use SEU or a variety of fuels. Typically, the reactor core is contained in a cylindrical austenitic stainless steel tank (calandria) which holds the heavy water moderator at low temperatures (<80°C) and low pressure (~0.1 MPa) [17]. The ends of the cylinder are closed with two parallel end shields which are perforated with holes for the fuel channels, the holes being arranged in a square lattice pattern. Thin walled Zircaloy 2 tubes are

fastened to each inner tube sheet and act as stays for the end shields in order to form a leaktight tank. The holes in each end shield are connected with stainless steel tubes (lattice tubes) (Fig. 4).

Each fuel channel consists of a Zr–2.5%Nb pressure tube joined to martensitic stainless steel end fittings, and occupies the tubular holes or lattice sites formed by each combined lattice tube and calandria tube. The fuel channel end fittings are supported on a pair of sliding bearings at each end, and the pressure tube is supported and separated from the calandria tube by annular spacers (Fig. 5).

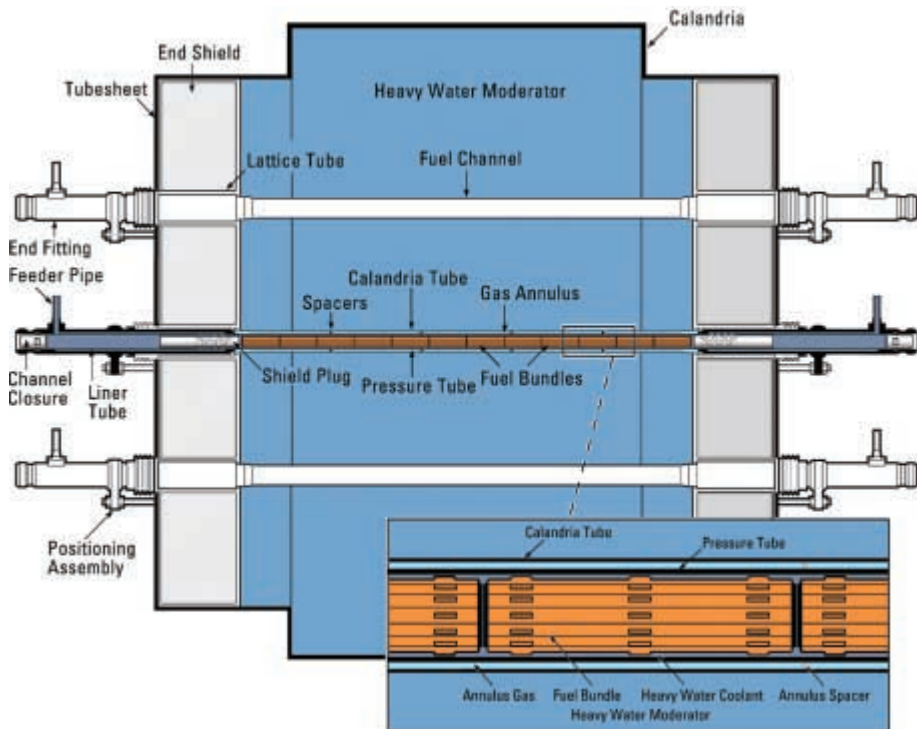
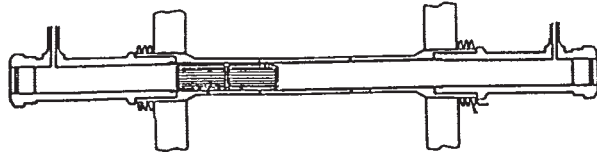

FIG. 4. Cross-section of CANDU calandria.



**SIMPLIFIED CROSS SECTION
OF A CANDU FUEL CHANNEL**

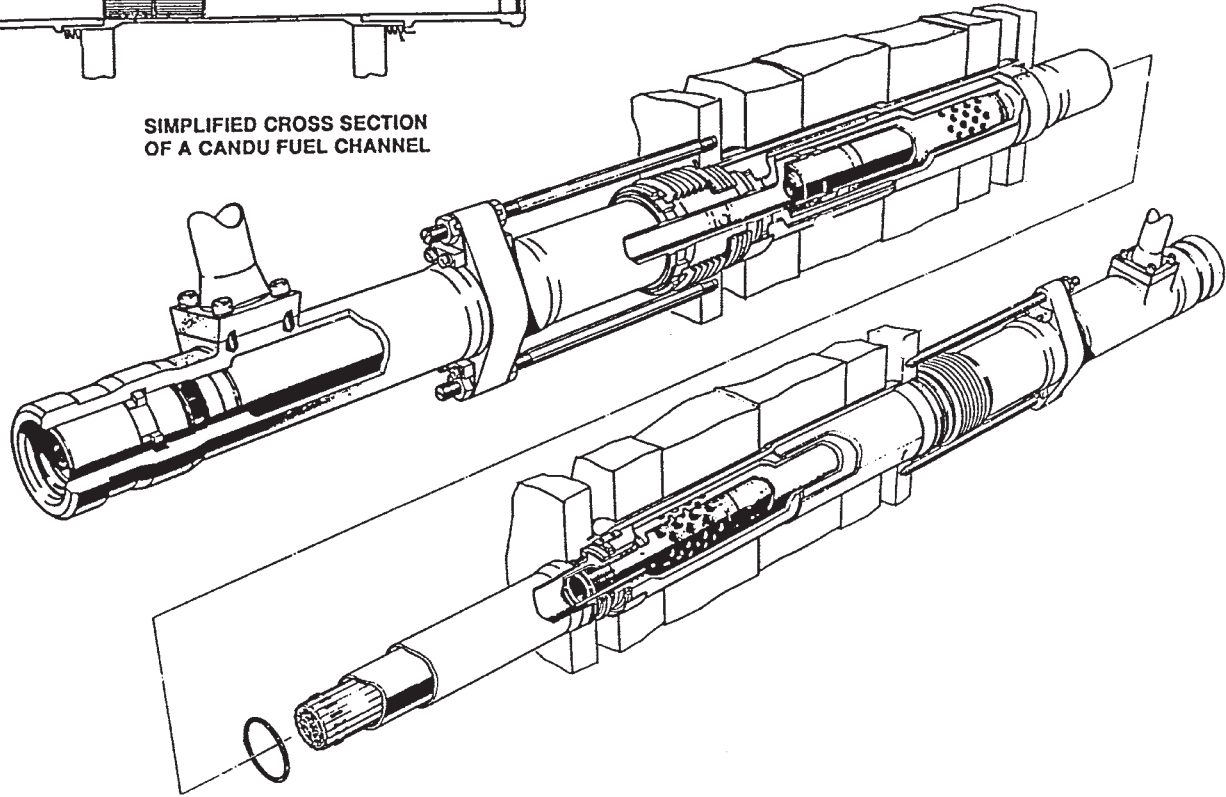

FIG. 5. CANDU PHWR fuel channel.

The end fittings have a closure plug at each end which can be removed by a fuelling machine in order to insert or remove 0.5 m long fuel bundles. The channel can contain either 12 (CANDU 6) or 13 (Bruce/Darlington 800 MW reactors) bundles. At a side port on each end fitting, the fuel channel is connected to feeder pipes. The coolant leaves each channel through carbon steel feeder pipes which transfer the heavy water coolant to and from the headers, from which it is sent to the steam generators before being pumped back to the channels. Control mechanisms operate in the cool moderator and are contained in tubular sheaths that penetrate the matrix of calandria tubes, either vertically or horizontally. An illustration of the reactor assembly is shown in Fig. 6.

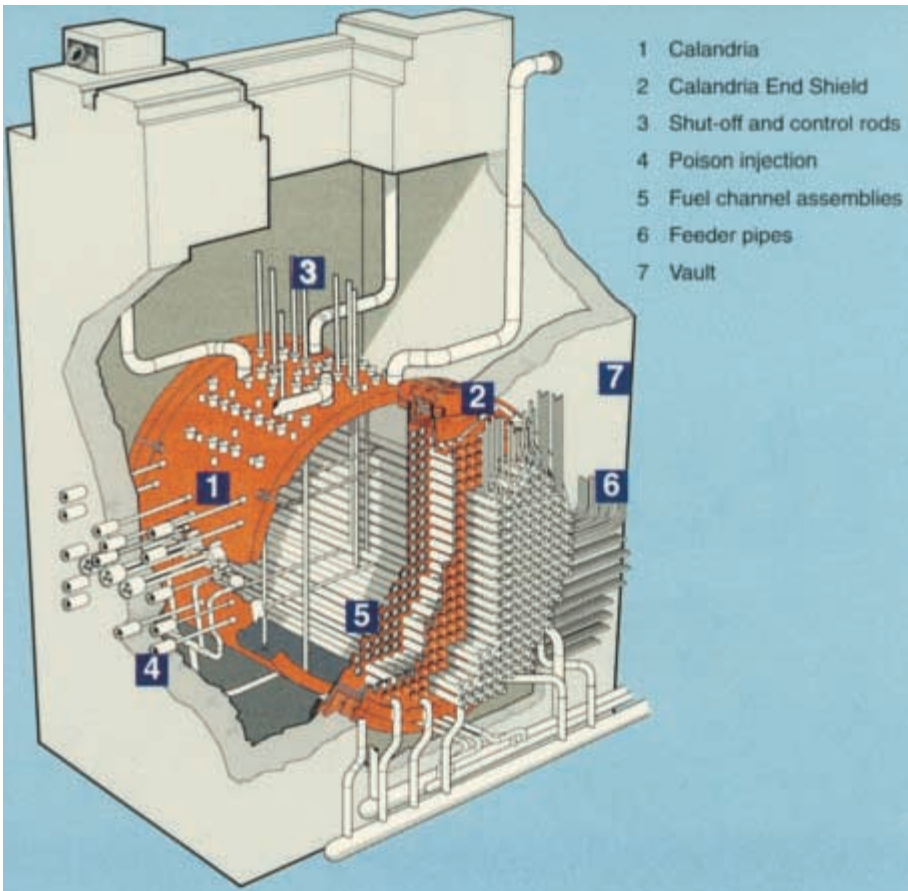

FIG. 6. Illustration of a CANDU PHWR.

3.1.2. Design and operating characteristics

The pressure tube, heavy water cooled, heavy water moderated reactor has certain characteristics which facilitate operation and safety analysis, and which provide fuel options [18]. These are summarized in the following sections.

3.1.2.1. Pressure tubes as the reactor pressure boundary

Pressure tube characteristics are as follows:

- Pressure tubes are thin walled components with a simple geometry. This facilitates repetitive manufacture and inspection, both pre-service and in-service.
- Pressure tubes are replaceable. At the end of their life, they can be replaced in order to extend the plant life.
- As a result of their having thin walls, there is no concern as regards overstressing the reactor pressure boundary under a fast cooldown, e.g. steam main break.
- A growing defect in a pressure tube, will in most cases, leak before the tube breaks, allowing detection by means of the annulus gas system and time for a shutdown to replace the tube.
- Even if a pressure tube should fail, the damage is limited to the channel itself and some surrounding in-core components. The other channels will not fail.
- The pressure tube geometry means that no fuel element is more than a few centimetres away from the moderator, which can act as an emergency heat sink for postulated severe accidents such as a loss of coolant accident (LOCA) combined with loss of emergency core cooling (LOECC). This also provides an inherent limit to metal–water reactions in a severe accident since the fuel bundle is close to the emergency heat sink.
- The horizontal channel orientation means that ‘graceful’ sagging occurs in the event of a beyond design basis severe core damage accident, that is, assuming a LOCA with LOECC and loss of moderator cooling, the fuel channels would slump onto the bottom of the calandria, resulting in heat transfer to the water in the shield tank (at which point some melting may occur).
- Pressure tubes preclude the possibility of a sudden, large, high pressure melt ejection occurring and eliminate one potential challenge to containment integrity.
- Since there are no large high pressure pipes directly connected to the reactor structure, there are no overturning forces placed on the reactor from a large LOCA.

3.1.2.2. *Fuel*

Fuel characteristics are as follows:

- The fuel design is simple and performs well. Typically, the defect rate in operating CANDU's is less than 0.1% of all bundles (even smaller, of the order of 0.001%, in terms of fuel elements).
- On-power fuelling means that there is very little reactivity hold-up needed in the reactor control system (and no need for boron in the coolant to hold down reactivity, resulting in a simpler design). The control rod reactivity worth can therefore be kept quite small (2 mk per rod or less).
- The high neutron economy, and hence low reactivity hold-up, of HWRs means that the reactor is very unlikely to become critical after any postulated beyond design basis severe core damage accident.
- The low remaining fissile content in spent fuel means that there are no criticality concerns in the spent fuel bay.
- The use of natural uranium fuel allows the storage and handling of new fuel with minimal criticality concerns since the fuel bundles require heavy water to become critical.

3.1.2.3. *Fuelling*

Fuelling characteristics are as follows:

- On-power refuelling, and a failed fuel detection system, allow fuel which becomes defective in operation to be located and removed without shutting down the reactor. This reduces the radiation fields from released fission products, allows access to most of the containment while the reactor is operating, and reduces operator doses.
- As a result of on-power fuelling, the core state does not change after about the first year of operation. Thus, the reactivity characteristics remain constant throughout plant life, resulting in simpler operation and analysis.
- The ability to couple tools to the fuelling machine allows it to be used for some inspections without necessitating removal of the pressure tube and in some instances without defuelling the channels.

3.1.2.4. *Moderator*

Moderator characteristics are as follows:

- The cool, low pressure moderator removes 4.5% of the fuel heat during normal operation; about the same as the amount of decay heat removed shortly after shutdown. It can therefore act as a long term emergency heat sink for a LOCA plus LOECC; the heat transfer is effective enough to prevent melting of the UO_2 fuel and preserve channel integrity.
- The HWR has an inherent prompt shutdown mechanism (besides the engineered shutdown systems and the control system) for beyond design basis severe core damage accidents. If steam is introduced into the moderator as a result of, for example, multiple channel failures, then the immediate effect of loss of moderation would cause the reactor to be shut down.
- In the case of a channel failure, the moderator acts as an energy absorbing ‘cushion’, preventing failure of the calandria vessel. Even for beyond design basis severe core damage accidents, where a number of channels are postulated to fail, the calandria may leak but would retain its gross structural integrity.
- The low pressure, low temperature moderator contains the reactivity mechanisms and distributes the chemical trim, boron, for reactivity purposes and gadolinium nitrate for shutdown purposes.

3.1.2.5. *Heat transport system (HTS)*

The heat transport characteristics are as follows:

- As a result of the economic value of heavy water, the designers of HWRs pay great attention to preventing coolant leaks. Leak detection equipment is highly sensitive and therefore leaks developing from whatever source can be detected very early.
- The HTS contains minimal chemical additives (LiOH for pH control and H_2 for producing a reducing chemistry).

3.1.2.6. *Shield tank*

Shield tank characteristics are as follows:

- The shield tank is a large source of water surrounding the calandria. In the case of beyond design basis severe core damage accidents such as a LOCA plus LOECC plus loss of moderator heat removal plus failure of make-up to the moderator, the shield tank can provide water to the outside of the calandria shell, ensuring that it remains cool and therefore intact, thereby keeping the damaged core material inside the calandria. Recent HWR designs have added make-up to the shield tank and steam relief to ensure that this is effective. Heat can be transferred from the debris through the thin walled calandria shell to the

shield tank without the debris melting through. This inherent 'core catcher' provides debris retention and cooling functions.

- As a severe core damage sequence can be stopped in the calandria, the challenge to containment is much reduced.

3.1.2.7. *Reactivity control*

Reactivity control characteristics are as follows:

- HWRs using natural uranium have a positive void coefficient, which leads to positive power coefficients. This is accommodated in the design by employing independent fast acting shutdown systems based on poison injection into the moderator and spring assisted shut-off rods.
- The long prompt neutron lifetime (about 1 ms) means that for reactivity transients even above prompt critical, the rate of rise in power is relatively slow. For example, the reactor period for an insertion of 5 mk is about 0.85 s^{-1} , whereas for 7 mk it is about 2.4 s^{-1} . The shut down systems are, of course, designed to preclude prompt criticality.
- The separation of coolant and moderator, and the slow time response of moderator temperature, eliminates moderator temperature feedback effects of power transients. The only way of diluting moderator poison (if present) is through an in-core break, which is small and the effect of which is slow relative to shutdown system capability.
- The reactivity control mechanisms penetrate the low pressure moderator, not the coolant pressure boundary. They are therefore not subject to pressure assisted ejection in the event of an accident and can be relied upon to perform their function.
- Both bulk power and spatial control are fully automated with digital control and computerized monitoring of the plant state, which simplifies the job of the operator and reduces the chances of operator error.
- The control, the adjuster and the shut-off rods are of simple design and have relatively large tolerances (e.g. loose fit in guide tubes). They do not interact with the fuel bundles at all and are not, therefore, subject to jamming in the event of an accident damaging the fuel.
- In the case of a severe accident (LOCA plus LOECC), the damaged fuel is confined to the fuel channels, and therefore there is no risk of melting the control rods.

3.1.2.8. Shutdown cooling

HWRs have a shutdown cooling system which can remove decay heat after shutdown from full pressure and temperature conditions. It is not necessary to depressurize the HTS.

3.1.2.9. Safety systems

The safe operation of a reactor necessitates that the fuel be kept adequately cool at all times in order to prevent loss of fuel cladding integrity and the consequent dispersion of radioactive species into the coolant. The safety systems that prevent or mitigate fuel damage are:

- Systems that shut down the reactor in the case of accidents (Section 3.1.2.7).
- Systems that refill the reactor fuel channels with water and remove residual or decay heat from the fuel. The emergency core cooling system (ECCS) fulfils this purpose. The fuel requires heavy water to go critical and the light water of the ECCS suppresses criticality. There is no need to add boron to the ECCS water.
- Systems that prevent release of radioactivity into the environment. The major system is the containment building. Current HWRs have a containment isolation system that has been demonstrated by on-power testing to have a probability of unavailability of less than 10^{-3} years/year. The building volumes are relatively large, resulting in low design pressures. Reference should be made to Section 5 for details of the operation of the safety systems.
- Most HWRs have two, independent, diverse, reliable, testable, redundant, fail-safe shutdown systems (as well as the control system) which do not share instrumentation, logic actuation devices or in-core components. One system uses rods, the other liquid poison injection. Each of the shutdown systems is effective, by itself, for all design basis accidents. With each one demonstrated by on-power testing to a reliability of 999 times out of 1000 attempts, the risk of a transient or accident occurring without shutdown is negligible.
- Each safety shutdown system has the ability to shut down the reactor from the most reactive state in an accident to zero power cold conditions. Moderator poison is only needed in the long term (hours) to compensate for xenon decay.
- The positive void coefficient, while it must be compensated for in an accident by the shutdown systems, has the advantage of resulting in fast and responsive neutronic trips for a number of accidents. It also ensures an inherent power reduction for rapid cooldown accidents such as steam main failure.

- Most HWRs have two sources of emergency electrical power: Group 1 Class III diesels and separate, independent, seismically qualified Group 2 Class III diesels. This greatly reduces the risk of station blackout.

3.1.2.10. *Licensing: Consultative process*

The HWR regulators' licensing philosophy usually places the onus on the proponent to demonstrate that the plant is safe while the regulator audits the result. The regulator does not prescribe the design in detail, thereby avoiding the conflict of interest inherent in reviewing its own design. Besides encouraging innovation, this process places full responsibility for safety on the organization which owns and operates the plant, consistent with IAEA recommendations.

3.1.2.11. *Licensing: Scope of safety analysis*

The scope of analysis aspect of licensing has the following characteristics:

- HWR regulations typically specify the classes of accident to be considered in the design. These include not only failures of an operating system (e.g. LOCA), but also such failures combined with a failure of the mitigating system (e.g. LOCA plus LOECC, with credit for only one shutdown system in any accident). The latter are design basis accidents in HWRs and must meet dose limits using deterministic analysis. The requirement to include these 'dual' failures means that the least unlikely severe accidents are *within* the design basis and must not cause severe core damage. This results in a robust design.
- Although the list of 'design basis' accidents is specified in part in regulations, the proponent is required to demonstrate that the analysis has covered a complete set. This ensures that the scope of analysis is comprehensive.
- Regulatory requirements in most HWR jurisdictions imply the use of probabilistic safety assessment (PSA), not just after the design is complete, but very early on in the design phase, when any identified weaknesses can still be rectified relatively inexpensively.

3.1.3. **Nuclear steam supply system (NSSS)**

3.1.3.1. *Introduction*

The CANDU 6 is used as the basis for describing the features of the CANDU HWR. All CANDU 6 power plants are fundamentally the same, although there are differences in detail which largely result from different site conditions and from

improvements made in the newer designs. The basic design features of the current generation of Indian 220 MW(e) HWRs and the 500 MW(e) versions are also generally similar except in some quantitative details. A separate description of these reactors has not been provided in order to avoid repetition of contents.

The generation of heat for the NSSS starts with controlled fission in the natural uranium fuel which is distributed among several hundred reactor fuel channels. Each 6 m long fuel channel is fuelled with 12 fuel bundles. Pressurized heavy water coolant is circulated through the fuel channels and steam generators in a closed circuit. The fission heat produced in the fuel is transferred to heavy water coolant flowing through the fuel channels, the coolant carrying the heat to the steam generators where it produces light water steam. This steam is used to drive the turbine generator to produce electricity. Figure 7 illustrates the process.

3.1.3.2. *Reactor assembly*

The generic features of the reactor assembly are described in Section 3.1.2.

3.1.3.3. *Fuel and fuel handling system*

The CANDU 6 HWR fuel bundle consists of 37 elements arranged in concentric rings as shown in Fig. 8. Each element consists of natural uranium in the form of cylindrical pellets of sintered uranium dioxide contained in a Zircaloy 4 sheath, capped at each end. The 37 elements are held together by welding them to end plates to form the fuel bundle. The required separation of the fuel elements is maintained by spacers brazed to the fuel elements at the transverse midplane. The outer fuel elements have bearing pads brazed to the outer surface to support the fuel bundle in the pressure tube and to prevent contact between the fuel element cladding and the pressure tube. Other fuel bundle designs, incorporating a different number of elements, are used in various reactors [19].

The fuel handling system:

- Provides facilities for the storage and handling of new fuel,
- Refuels the reactor remotely while it is operating at any level of power,
- Transfers the irradiated fuel remotely from the reactor to the storage bay.

The fuel changing operation is based on the combined use of two remotely controlled fuelling machines, one operating at each end of a fuel channel (Fig. 9). New fuel bundles, from one fuelling machine, are inserted into a fuel channel in the same direction as the coolant flow and the displaced irradiated fuel bundles are received into the second fuelling machine at the other end of the fuel channel [20]. Typically, either 4 or 8 of the 12 fuel bundles in a fuel channel are exchanged during

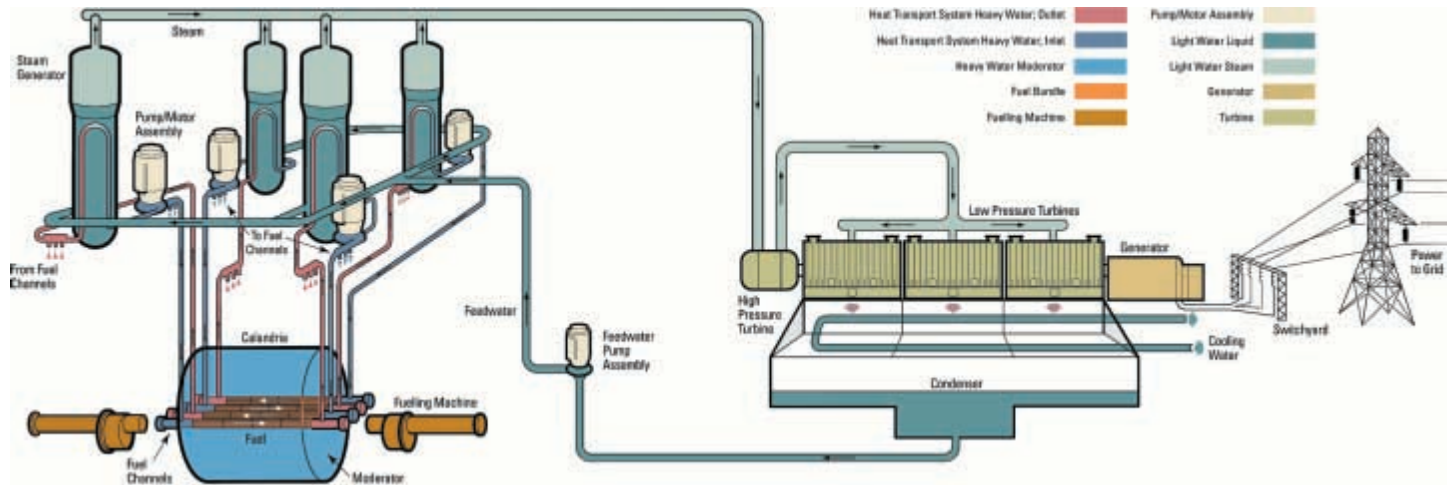

FIG. 7. Nuclear steam supply system.

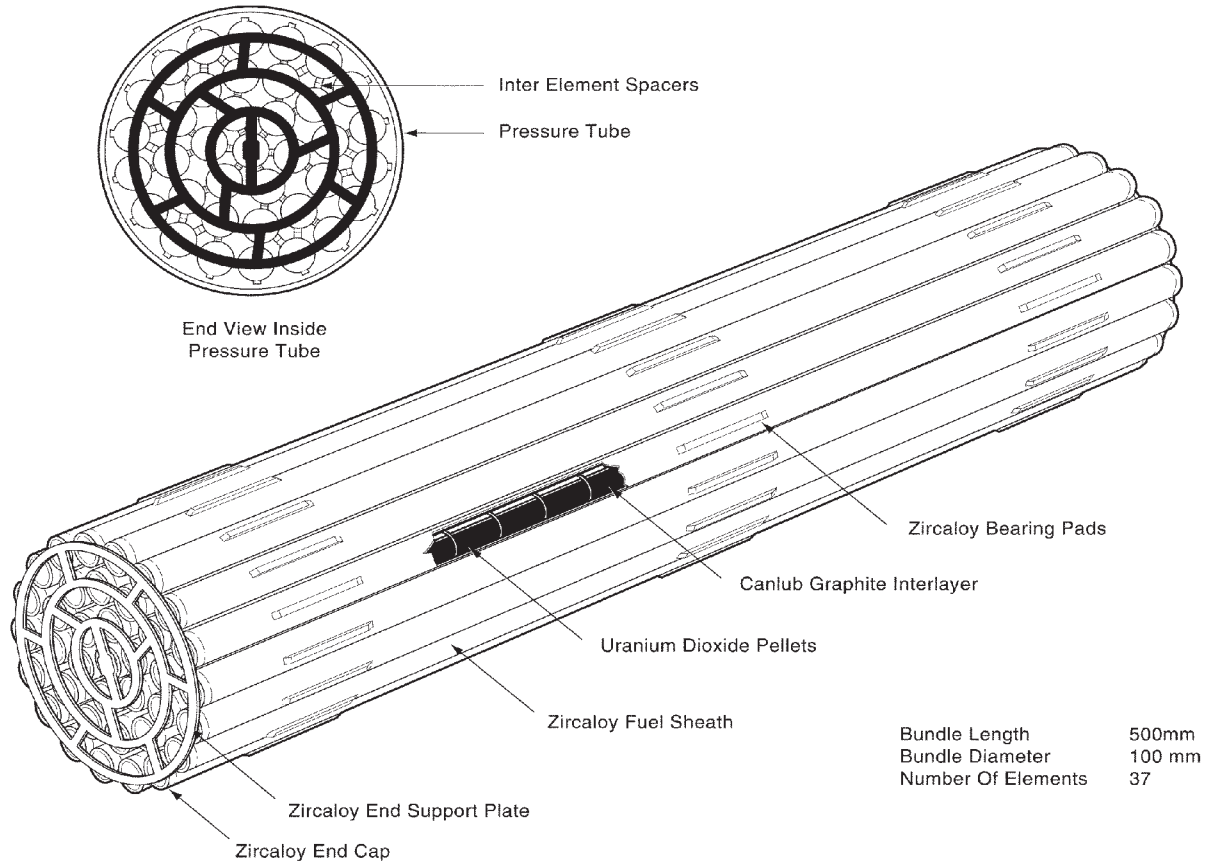

FIG. 8. CANDU 37 element fuel bundle.

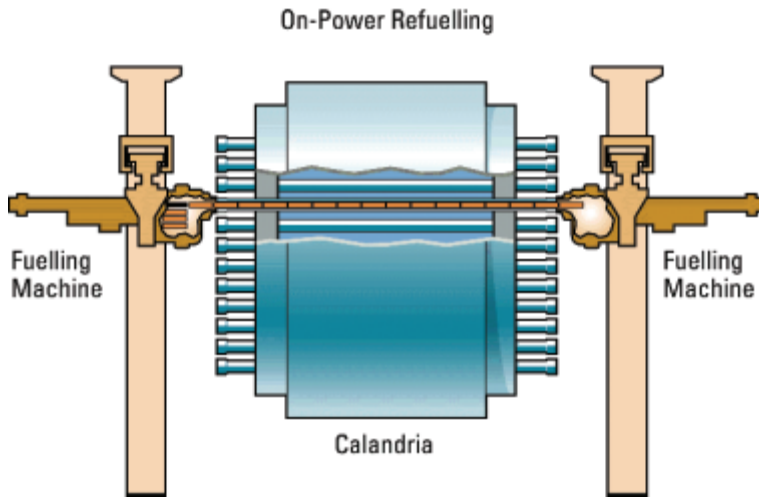

FIG. 9. On-power refuelling.

a refuelling operation. In the case of a CANDU 6 size reactor, an average of 10 natural uranium fuel channels are refuelled each week.

Either machine can load or receive fuel. The direction of loading depends upon the direction of coolant flow in the fuel channel being fuelled, which alternates from channel to channel.

The fuelling machines receive new fuel while connected to the new fuel port and discharge irradiated fuel while connected to the discharge port. The entire operation is directed from the control room through a preprogrammed computerized system. The control system provides a printed log of all operations and permits manual intervention by the operator.

New fuel is received in the new fuel storage room located in the service building. This room accommodates six months' fuel inventory and can store, temporarily, all the fuel required for the initial fuel loading.

When required, the fuel bundles are transferred to the new fuel transfer room located in the reactor building. The fuel bundles are identified and loaded manually into the magazines of the two new fuel ports. Transfer of the new fuel bundles into the fuelling machines is remotely controlled.

Irradiated fuel received in the discharge port from the fuelling machine is transferred remotely onto an elevator which lowers it into a discharge bay filled with light water. The irradiated fuel is then conveyed, under water, through a transfer canal

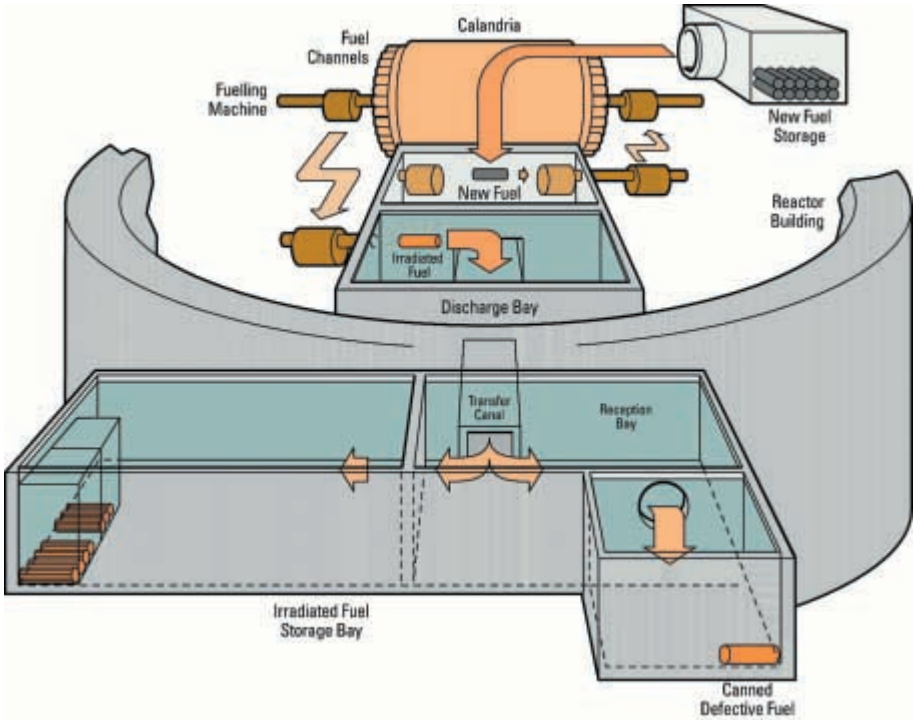

FIG. 10. Fuel transfer system for CANDU PHWR.

into a reception bay, where it is loaded onto storage trays or baskets and passed into the storage bay (Fig. 10).

The discharge and transfer operations are remotely controlled by station staff. Operations in the storage bays are carried out under water, using special tools aided by cranes and hoists. Defective fuel is inserted into cans under water to limit the spread of contamination before transfer to the fuel bay. The storage capacity of the bays is sufficient to accommodate a minimum of 10 years' accumulation of irradiated fuel.

Neither new nor irradiated CANDU fuel can achieve criticality in air or light water, regardless of the storage configuration. Thus, dry storage of fuel is possible after interim storage in the spent fuel bay. Provision for safeguarding fuel is made by putting an identification number on each bundle, which is recorded at various stages during fuel usage to facilitate traceability.

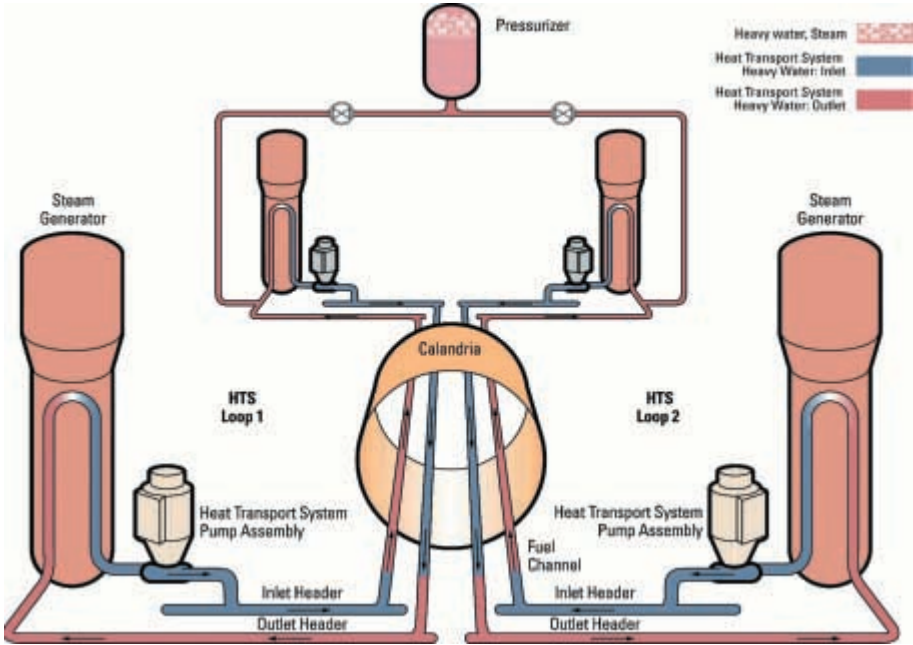

FIG. 11. Two loop HTS in a CANDU PHWR.

3.1.3.4. HTS

The primary heat transport system (PHTS) in a CANDU 6 unit consists of two loops arranged in a figure-of-eight configuration with the coolant making two passes in opposite directions through the core during each complete circuit (Fig. 11) [21]. The two PHTS pumps in each loop operate in series, causing the coolant to transport the fission heat generated in the fuel to the steam generators where it is transferred to light water, producing steam to drive the turbine. Each loop has one inlet and one outlet header at each end of the reactor core. The coolant is fed to each of the fuel channels through individual feeder pipes and returned from each channel through individual feeder pipes to the outlet headers.

The pressure in the PHTS of a CANDU 6 reactor is controlled by a pressurizer connected to the outlet headers at one end of the reactor.² Valves can isolate the two

² Nuclear power plants which do not allow the coolant to boil in the channels, do not use a pressurizer and rely on the feed and bleed system for control.

loops in the event of a LOCA. Pressure in the pressurizer is controlled by heaters in the pressurizer and by steam bleed. Other key features of the circuit are:

- The steam generators consist of an inverted U-tube bundle housed within a cylindrical shell. The steam generators include an integral preheater on the secondary side of the U-tube outlet section, and integral steam separating equipment in the steam drum above the U-tube bundle.
- The heat transport pumps are centrifugal motor driven pumps, mounted with the shaft vertical and with a single suction and double discharge.
- In the event of electrical power supply interruption, cooling of the reactor fuel is maintained for a short period of time by the rotational momentum of the heat transport pumps during reactor power rundown, and by natural convection after the pumps have stopped.
- Chemistry control is relatively simple because chemicals do not have to be added to the PHTS for the purpose of reactivity control.
- Carbon steel piping, which is ductile and relatively easy to fabricate and to inspect, is used in the HTS. Low concentrations of chromium are nowadays added to the steel to prevent flow assisted corrosion from outlet water undersaturated in iron.

3.1.3.5. Heat transport auxiliary systems

Four auxiliary systems, attached to the HTS to perform specific functions, are illustrated in Figs 12 and 13.

(a) Pressure and inventory control system

The heat transport pressure and inventory control system provides:

- Pressure and inventory control for each HTS loop,
- Overpressure protection,
- A controlled degassing flow.

The system consists of a pressurizer, D₂O feed pumps, feed and bleed valves, D₂O storage tank, degasser condenser, liquid relief valves and safety valves.

Heavy water in the pressurizer is heated electrically to pressurize the vapour space above the liquid. The volume of the vapour space is designed to cushion pressure transients, without allowing excessively high or low pressures to be generated in the HTS.

The pressurizer also accommodates the change in volume of the reactor coolant occurring in the HTS when the reactor moves from zero power to full power. This

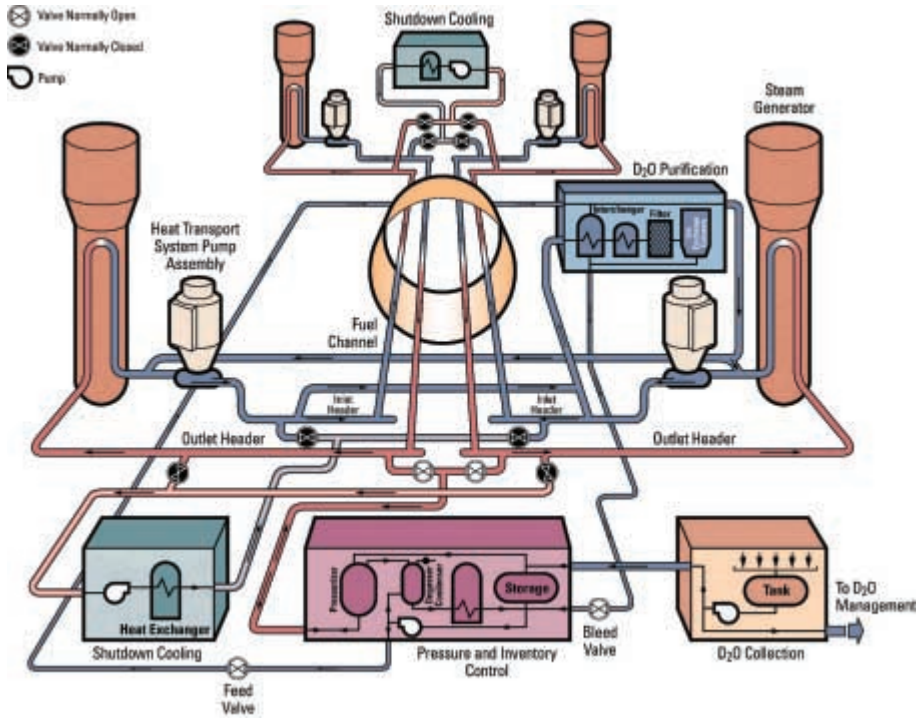

FIG. 12. Auxiliary systems of the HTS.

permits the reactor power to be increased or decreased rapidly, without imposing a severe demand on the D_2O feed and bleed components of the system.

When the reactor is at power, pressure is controlled by the pressurizer, heat is added to the pressurizer via the electric heaters in order to increase pressure, and heat is removed from the pressurizer via the D_2O steam bleed to reduce pressure. The coolant inventory is adjusted by the feed and bleed circuit. Pressure can also be controlled by the feed and bleed circuit with the pressurizer isolated at low reactor power and when the reactor is shut down. This feed and bleed circuit is designed to accommodate the changes in coolant volume that take place during heat-up and cooldown.

(b) D_2O collection system

The main purpose of the D_2O collection system is to:

- Collect leakage from mechanical components,
- Receive D_2O sampling flow,
- Receive D_2O drained from equipment prior to maintenance.

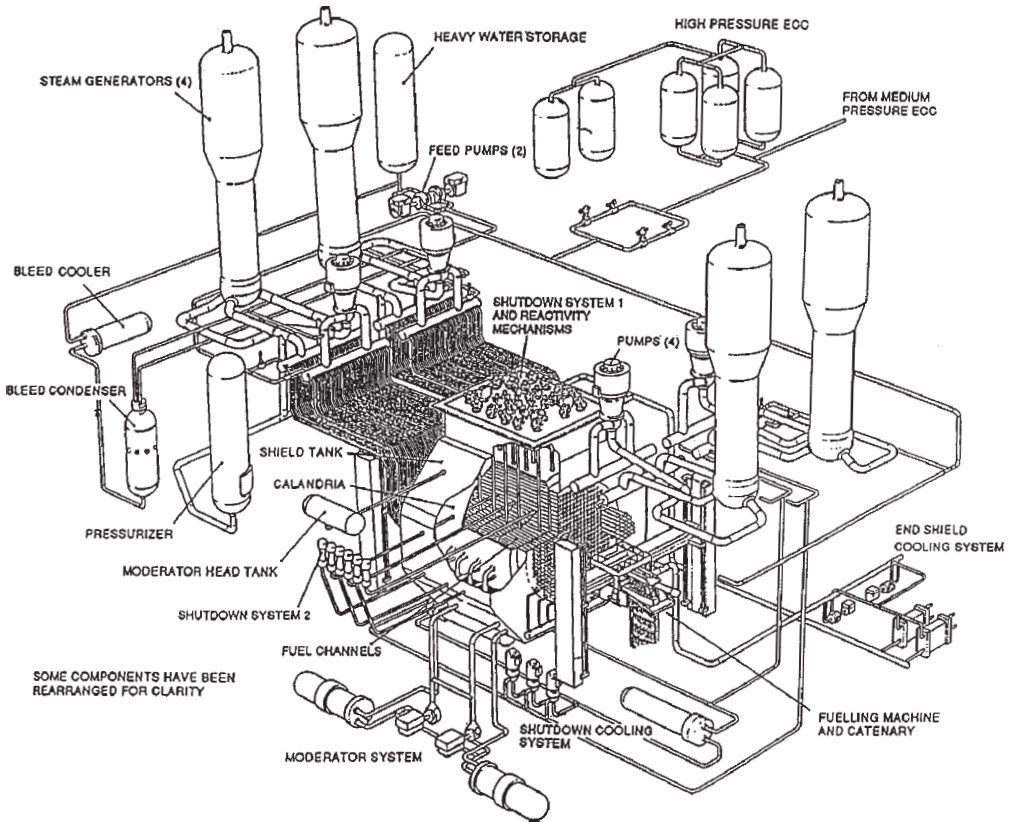

FIG. 13. Illustration of the relative location of components in the CANDU PHWR and the auxiliary systems' components in the HTS and the moderator system.

The collected D_2O is pumped from the collection tank to the storage tanks of the pressure and inventory control system for reuse in the HTS. However, if the isotopic purity of the collection tank contents is low, the D_2O can be pumped into drums for upgrading.

(c) Shutdown cooling system

The shutdown cooling system is capable of:

- Cooling the HTS from $177^\circ C$ down to $54^\circ C$, and holding the system at that temperature indefinitely;

- Providing core cooling during maintenance work on the steam generators and heat transport pumps when the HTS is drained down to the level of the headers;
- Being put into operation with the HTS at full temperature and pressure.

The shutdown cooling system consists of two independent circuits, one located at each end of the reactor. Each circuit consists of a pump and a heat exchanger, connected between the inlet and outlet headers of both HTS loops. The system is normally full of D₂O and isolated from the HTS by power operated valves.

The shutdown cooling pumps are sized to ensure that boiling does not occur in any of the fuel channels at initial startup. During normal cooldown, steam from the steam generators bypasses the turbine and flows into the turbine condenser, thereby reducing the HTS temperature to 177°C in approximately 30 minutes.

In order to achieve cooldown from 177°C to 77°C, the isolating valves at the reactor headers are opened and all heat transport pumps are kept running. The heat transport pumps force a portion of the total core flow through the shutdown cooling heat exchangers where it is cooled by recirculated cooling water flowing around the heat exchanger coils.

After cooling to below 100°C, the heat transport pumps are shut down and the shutdown cooling system pumps started. The system is then cooled to 54°C in this mode, enabling D₂O to be drained down to the level just above the reactor headers, if required for maintenance of the steam generators or pumps.

(d) Purification system

The heat transport purification system:

- Limits the accumulation of corrosion products in the coolant by removing soluble and insoluble impurities,
- Removes accumulations of fine solids following their sudden release due to chemical, hydraulic or temperature transients,
- Maintains the pD (pH of D₂O) within the required range.

Flow is taken from one reactor inlet header of each heat transport loop, passed through an interchanger, cooler, filter and ion exchange column before being returned through the interchanger to a pump inlet in each circuit. The pressure generated by the heat transport pump produces the flow through the purification system. The interchanger-cooler combination minimizes the heat loss in the D₂O purification cycle.

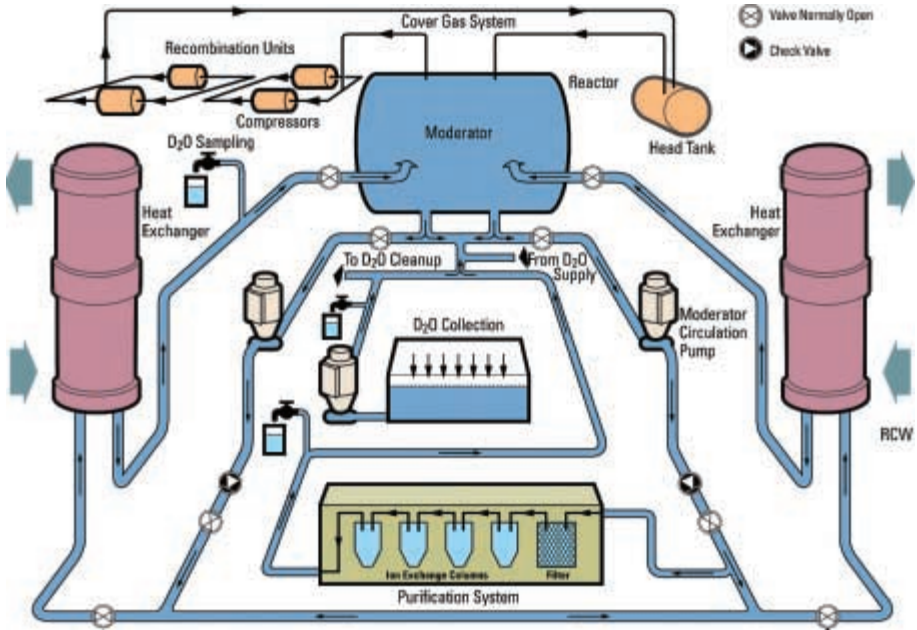

FIG. 14. Schematic diagram of the moderator system.

3.1.3.6. Moderator and auxiliary systems

The moderator receives 4.5% of reactor thermal power. The largest portion of this heat is from gamma radiation. Additional heat is generated by moderation (slowing down) of the fast neutrons produced by fission in the fuel and a small amount of heat is transferred to the moderator from the hot pressure tubes. For reactivity control, gadolinium, and occasionally boron, can be added or removed from the moderator fluid.

The moderator system includes two 100% capacity pumps, two 50% flow capacity heat exchangers cooled by recirculated light water, and a number of control and check valves. Connections are provided for the purification, liquid poison addition, heavy water (D₂O) collection, supply and sampling systems (Fig. 14).

The series/parallel arrangement of the moderator system lines and valves permits the output from either pump to be cooled by both of the heat exchangers and ensures an acceptable level of moderator cooling when either of the two pumps is isolated for maintenance. Reactor power must be reduced to about 60% if one moderator heat exchanger is isolated. The primary functions of the system are to:

- Provide moderator cooling,
- Control the level of heavy water in the calandria,
- Maintain the calandria outlet temperature at approximately 70°C.

The normal electric power supplied to the moderator system is backed up with an emergency power supply.

The heavy water in the calandria functions as a heat sink in the unlikely event of a LOCA in the HTS coinciding with a failure of emergency core cooling.

Helium is used as a cover gas for the moderator system because it is chemically inert and is not activated by neutron irradiation. Radiolysis of the heavy water moderator in the calandria results in the production of deuterium and oxygen gases. Circulation of the cover gas to catalytic recombiners reforms heavy water and prevents accumulation of these gases. The deuterium and oxygen concentrations are maintained well below levels at which an explosion hazard would exist.

The cover gas system includes two compressors and two recombination units which form a circuit for the circulation of cover gas through the calandria relief ducts. Normally, one compressor and both recombination units are operated, with the other compressor held on stand-by. The moderator purification system:

- Maintains the purity of D₂O, thereby minimizing radiolysis which can cause excessive production of deuterium in the cover gas;
- Minimizes corrosion of components by removing impurities present in the D₂O and by controlling the pH;
- Reduces, under operator command, the concentration of the soluble poisons, boron and gadolinium, in response to reactivity demands;
- Removes the soluble poison gadolinium after shutdown system 2 (SDS2) has operated.

Isolation valves in the purification system inlet and outlet lines are provided for maintenance purposes. The valves also allow drainage of the HTS coolant to just above the elevation of the headers without the need to drain the purification system. These valves close automatically in the event of LOCA.

The D₂O sampling system allows samples to be taken from the:

- Main moderator system,
- Moderator D₂O collection system,
- Moderator purification system,
- D₂O cleanup system.

Analyses may be performed on the samples to establish whether the chemistry of the heavy water falls within the specified range of chemistry parameters. These

parameters include pD, conductivity, chloride concentration, isotopic purity, boron and gadolinium concentrations, tritium concentration, fluoride concentration and organic content.

3.1.3.7. Reactor regulating system

The fundamental design requirement of the reactor regulating system is to control the reactor power at a specified level and, when required, to manoeuvre the reactor power level between set limits at specific rates.

The reactor regulating system combines the reactor's neutron flux and thermal power measurements by means of reactivity control devices and a set of computer programs to perform three main functions:

- Monitor and control total reactor power in order to satisfy station load demands,
- Monitor and control reactor flux shape,
- Monitor important plant parameters and reduce reactor power at an appropriate rate if any parameter is outside specific limits.

Reactor regulating system action is controlled by digital computer programs which process the inputs from various sensing devices and activate the appropriate reactivity control devices.

All neutron flux measurement and control devices, both vertical and horizontal, are located in the low pressure calandria perpendicular to, and between, the horizontal fuel channels (Fig. 15) [22].

Computer programs provide the following:

- Reactor power measurement and calibration,
- Demand power routine,
- Reactivity control and flux shaping,
- Set-back routine,
- Step-back routine,
- Flux mapping routine.

The principal instrumentation utilized for reactor regulation includes:

- Ion chamber system,
- Self-powered, in-core flux detectors,
- Thermal power instrumentation.

The nuclear instrumentation systems are designed to measure reactor neutron flux over the full operating range of the reactor. These measurements are

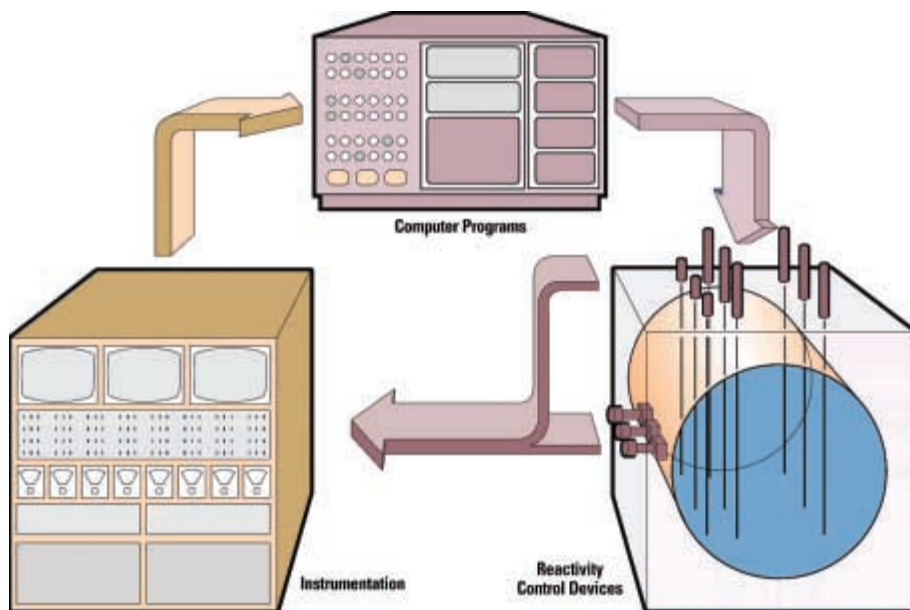

FIG. 15. CANDU PHWR reactor regulating system.

required as inputs to the reactor regulating system and safety systems. The instrumentation for the safety systems is independent of that used by the reactor regulating system.

The reactivity control devices provide short term global and spatial reactivity control. The devices are of two major types: mechanical and liquid.

The mechanical devices are the mechanical control absorbers and adjuster assemblies. The mechanical control absorbers comprise tubes containing cadmium (a neutron absorber) which can be inserted to reduce power quickly. The adjuster assemblies comprise stainless steel tubes which are used to produce axial flattening of the fuel bundle powers as necessary. They can be removed from the core in order to add reactivity.

The liquid reactivity devices consist of the light water zone control units and the liquid poison addition system.

The function of the zone control system is to maintain a specified amount of reactivity in the reactor; this amount being determined by the deviation from the specified reactor power set point. If the zone control system is unable to provide the necessary correction, the program in the reactor regulating system draws on other reactivity control devices. Positive reactivity can be added by withdrawal of

absorbers. Negative reactivity can be induced by insertion of mechanical control absorbers or by automatic addition of poison to the moderator.

The reliability of the reactor regulating system is of paramount importance and is achieved through having:

- Direct digital control from dual redundant control computers,
- Self-checking and automatic transfer to the stand-by computer on fault detection,
- Control programs that are independent of each other,
- Duplicated control programs,
- Duplicated and triplicated inputs,
- Hardware interlocks that limit the amount and rate of change of positive reactivity devices.

3.1.4. Balance of plant

3.1.4.1. Introduction

The balance of plant comprises the steam lines from the steam generators, the steam turbines and the alternating electrical generator, the condenser, various moisture separators and equipment to achieve de-aeration, demineralization, oxygen scavenging, reheating and pH control of the feedwater returned to the steam generator.

The turbine generator system comprises steam turbines directly coupled to an alternating current (AC) electrical generator operating at synchronous speed.

The steam turbine is a tandem compound unit, generally consisting of a double flow, high pressure turbine and three double flow, low pressure turbines, which exhaust to a high vacuum condenser for maximum thermal efficiency. The condenser may be cooled by sea, lake or river water, or by use of atmospheric cooling towers.

The generator is a high efficiency, hydrogen cooled machine arranged to supply AC at medium voltage to the electric power system.

3.1.4.2. Feedwater and main steam system

Feedwater flows from the condenser via the regenerative feedwater heating system and is supplied separately to each steam generator. The feedwater is pumped into the steam generators by feedwater pumps with the flow rate to each steam generator regulated by feedwater control valves. A check valve in the feedwater line of each steam generator is provided to prevent backflow in the unlikely event of feedwater pipe failure. An auxiliary feedwater pump is provided to satisfy low power feedwater requirements during shutdown conditions, or in the event that the main feedwater pumps become unavailable (Fig. 16).

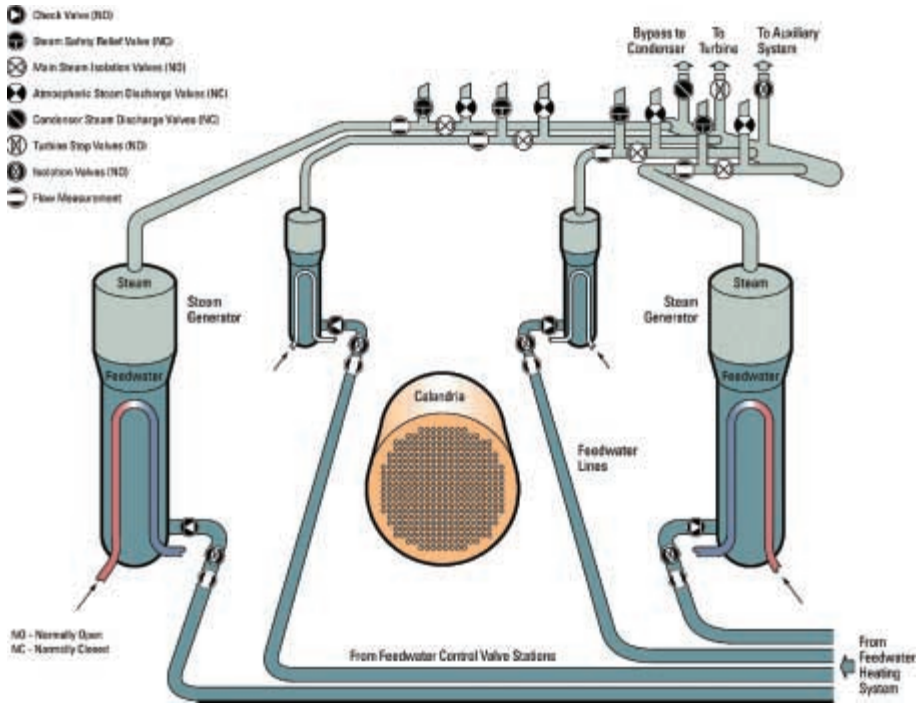

FIG. 16. CANDU feedwater and main steam system.

The chemistry of the feedwater to the steam generators is precisely controlled by demineralization, de-aeration, oxygen scavenging and pH control. A blowdown system is provided for each steam generator which allows impurities collected in the steam generators to be removed in order to prevent their accumulation and possible long term corrosive effects. In some reactors, the blowdown is collected and recirculated.

The heat supplied to the steam generators produces steam from the water which flows over the outside of the tubes. Moisture is removed from the steam by the steam separating equipment located in the drum (upper section) of the steam generator. The steam then flows via four separate steam mains, through the reactor building wall, to the turbine where they connect to the turbine steam chest via a main steam line isolation valve.

The steam pressure is normally controlled by the turbine governor valves that admit steam to the high pressure stage of the turbine. If the turbine is unavailable, up to 70% of full power steam flow can bypass the turbine and go directly to the condenser. During this operation, pressure is controlled by the turbine bypass

valves. Auxiliary bypass valves are also provided to permit up to 10% of full power steam flow to discharge to the condenser during low power operation.

Steam pressure can be controlled by discharging steam directly into the atmosphere via four atmospheric steam discharge valves which have a combined capacity of 10% of full power steam flow. These valves are used primarily for control during warm-up or cooldown of the HTS.

Overpressure protection of the steam system is provided by four safety relief valves connected to each steam main.

3.1.4.3. Turbine generator system

The steam produced in the steam generators enters a single high pressure turbine and its water content increases as it expands through this high pressure stage. On leaving this stage, the steam passes through separators where the moisture is removed. It then passes through reheaters where it is heated by live steam taken directly from the main steam lines. The reheated steam then passes through the low pressure turbines and into the condenser where it condenses to water which is then returned to the steam generators via the feedwater heating system (Fig. 17).

The steam turbine is a tandem compound unit, directly coupled to an electrical generator by a single shaft. It comprises one double flow, high pressure cylinder followed by external moisture separators, live steam reheaters and three double flow, low pressure cylinders (recent and future plants have two low pressure cylinders). The turbine is designed to operate with saturated inlet steam. The turbine system has main steam stop valves, governor valves, and reheat intercept and emergency stop valves, depending on the arrangement preferred by the architect-engineer. All of these valves close automatically in the event of a turbine protection system trip.

The generator is a three phase, four pole machine which typically operates at 1800 rpm to serve 60 c/s electrical systems, and at 1500 rpm to serve 50 c/s systems.

The associated equipment consists of a solid state automatic voltage regulator that controls a thyristor converter which in turn supplies the generator field via a field circuit breaker, generator slip rings and brush gear.

The main power output from the generator to the step-up transformer is by means of a forced air-cooled, isolated phase bus duct, with tap offs to the unit service transformer, excitation transformer and potential transformer cubicle.

The turbine condenser consists of three separate shells, each shell being connected to one of the three low pressure turbine exhausts. Steam from the turbine flows into the shell where it flows over a tube bundle assembly through which cooling water is pumped and is condensed. The condenser cooling water system typically consists of a once through circuit, using sea, lake or river water. The condensed steam collects in a tank at the bottom of the condenser (termed the 'hot well'). A vacuum

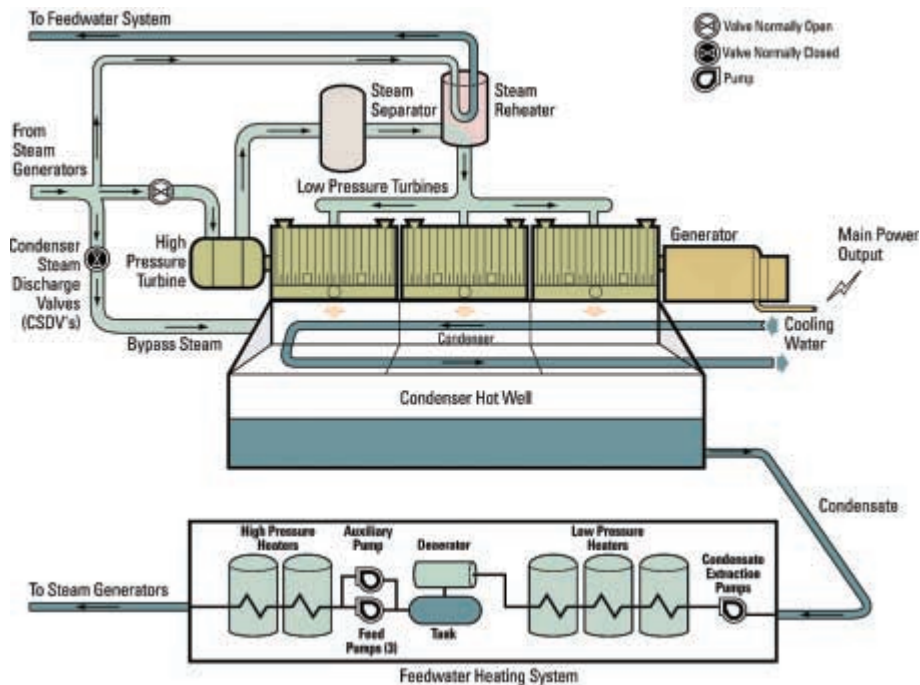

FIG. 17. Typical CANDU turbine generator system.

system is provided to remove air and other non-condensable gases from the condenser shells. The condenser is designed to accept turbine bypass steam, thereby permitting the reactor power to be reduced from 100% to 70% if the turbine is unavailable. The bypass can accept 100% steam flow for a few minutes, and 70% of full power steam flow continuously.

On its return to the steam generators, condensate from the turbine condenser is pumped through the feedwater heating system. First, it passes through three low pressure feedwater heater units, each of which contains two heaters fed by independent regenerative lines. This permits maintenance work to be carried out on the heaters with only a small effect on the turbine generator output. Two of the heater units incorporate drain cooling sections and the third a separate drain cooling stage. Next, the feedwater enters a de-aerator where dissolved oxygen is removed. From the de-aerator, the feedwater is pumped to the steam generators through two high pressure feedwater heaters, each incorporating drain cooling sections.

3.1.4.4. *Electric power system station services*

The other major system of a nuclear plant is the electric power system. The normal electric power system comprises a main power output transformer, unit and service transformers, and a switchyard. This system steps up (increases) the generator output voltage to match the electric utility's grid requirements for transmission to the load centres and also supplies the power needed to operate all of the station services.

The main switchyard portion of the electric power system permits switching outputs between transmission lines and comprises automatic switching mechanisms and lightning and earthing protection to shield the equipment against electrical surges and faults.

The station services power supplies are classified according to their levels of reliability requirement. The reliability requirement of these power supplies is divided into four classes that range from uninterruptible power to that which can be interrupted with limited and acceptable consequences. The electric power system station services comprise:

(1) *Class IV power supply*: Power to auxiliaries and equipment that can tolerate long duration interruptions without endangering personnel or station equipment is obtained from a Class IV power supply. This class of power supply comprises:

- Two primary medium voltage buses, each connected to the secondary windings of the system service and unit service transformers in such a way that only one bus is supplied from each transformer.
- Two medium voltage buses supplied from the secondary windings of two transformers on the primary medium voltage buses. These buses supply the main heat transport pumps, feed pumps, water circulation pumps, extractor pumps and chillers.

A complete loss of Class IV power will initiate a reactor shutdown.

(2) *Class III power supply*: AC supplies to auxiliaries that are necessary for the safe shutdown of the reactor and turbine are obtained from the Class III power supply with a stand-by diesel generator backup. These auxiliaries can tolerate short interruptions in their power supplies. This class of power supply comprises:

- Two medium voltage buses supplied from the secondary windings of the two transformers on the Class IV primary medium voltage buses. These buses supply power to the pumps in the service water system, ECCS, moderator circulation system, shutdown cooling system, HTS feed lines, steam generator auxiliary feed line, and the air compressors and chillers.

- A number of low voltage buses.

(3) *Class II power supply*: Uninterruptible AC supplies for essential auxiliaries are obtained from the Class II power supply, which comprises:

- Two low voltage AC three phase buses which supply critical motor loads and emergency lighting. These buses are each supplied through an inverter from a Class III bus via a rectifier in parallel with a battery.
- Three low voltage AC single phase buses which supply AC instrument loads and the station computers. These buses are fed through an inverter from Class I buses, which are fed from Class III buses via rectifiers in parallel with batteries.

In the event of inverter failure, power is supplied directly to the applicable low voltage bus and through a voltage regulator to the applicable instrument bus. If a disruption or loss of Class III power occurs, the battery in the applicable circuit will provide the necessary power without interruption.

(4) *Class I power supply*: Uninterruptible direct current (DC) supplies for essential auxiliaries are obtained from the Class I power supply, which comprises:

- Three independent DC instrument buses, each supplying power to the control logic circuits and to one channel of the triplicated reactor safety circuits. These buses are each supplied from a Class III bus via a rectifier in parallel with a battery.
- Three DC power buses which provide power for DC motors, switchgear operation and for the Class II AC buses via inverters. These DC buses are supplied from Class III buses via a rectifier in parallel with batteries.

(5) *Automatic transfer system*: In order to ensure continuity of supply in the event of a failure of either the unit or system power, an automatic transfer system is incorporated on the station service buses. Transfer of load from one service transformer to the other is accomplished by:

- A manually initiated transfer of power under normal operating conditions, or an automatically initiated transfer for mechanical trips on the turbine.
- A fast, open transfer of power, supplied automatically to both load groups of the Class IV power supply system, when power from one transformer is interrupted. This fast transfer ensures that the voltage and the phase differences between the incoming supply and the residual on the motors have no time to increase to a level that would cause excessive inrush currents.

- A residual voltage transfer, comprising automatic closure of the alternate breaker after the residual voltage has decayed by approximately 70%. This scheme is time delayed, may require load shedding and could result in reactor power cut-back. It is provided as a backup to the above transfers.

(6) *Station battery banks*: The station battery banks are all on continuous charge from the Class III power supply and in the event of a Class III power disruption will provide power to their connected buses.

(7) *Stand-by generators*: Stand-by power for the Class III loads is supplied by diesel generator sets, housed in separate rooms with fire resistant walls. Redundant diesel generators are available, capable of supplying the total safe shutdown load of the unit. The Class III shutdown loads are duplicated, one complete system being fed from each diesel generator. In the event of a failure of Class IV power, diesel generators will start automatically.

The generators can be up to speed and ready to accept load in less than two minutes. The total interruption time is limited to three minutes. Each generator automatically energizes half of the shutdown load through a load sequencing scheme. There is no automatic electrical tie between the two generators, nor is there a requirement for them to be synchronized. In the event of one generator failing to start, the total load will be supplied from the other generator.

(8) *Emergency power supply system*: The emergency power supply system can provide all shutdown electrical loads that are essential for safety. This system and its buildings are seismically qualified to be operational after an earthquake. The system provides a backup for one group of safety systems (SDS2, emergency water supply (EWS), secondary control area) if normal electric supplies become unavailable or if the main control room becomes uninhabitable. The system comprises two diesel generating sets, housed in separate fire resistant rooms, which are self-contained and completely independent of the station's normal services. There is adequate redundancy provided in both the generating distribution equipment and the loads.

3.1.4.5. *Station instrumentation and control*

Digital computers are used for station control, alarm annunciation, graphic data display and data logging. The system consists of two independent digital computers (DCCX and DCCY), each capable of station control (Fig. 18).

Both computers run continuously, with programs in both machines switched on, but only the controlling computer's outputs are connected to the station equipment. In the event that the controlling or directing computer fails, control of the station is

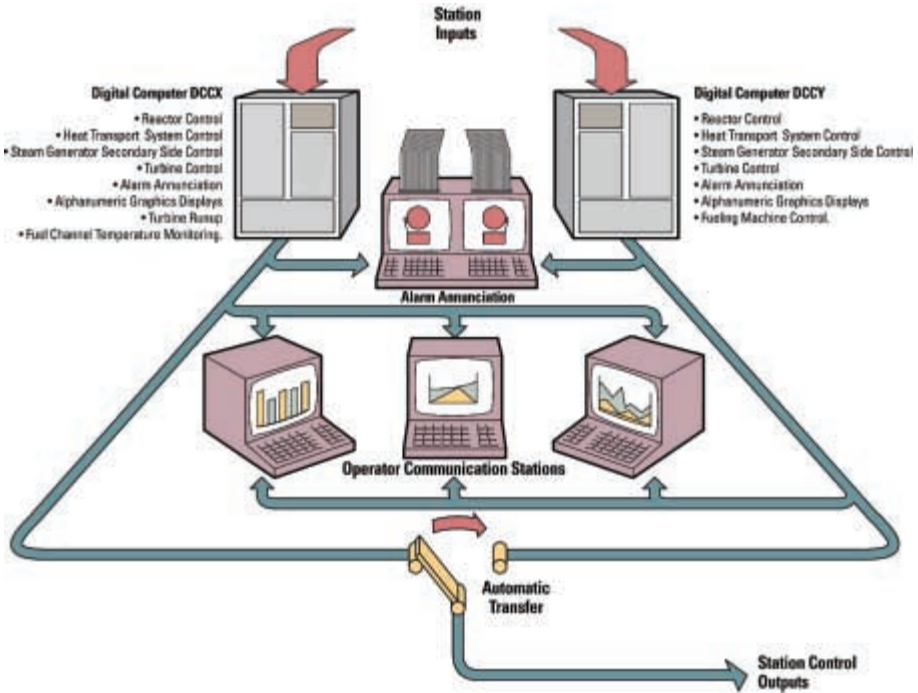

FIG. 18. Station instrumentation and control — digital control.

automatically transferred to the ‘hot’ stand-by computer. In the event of a dual computer failure, the station will automatically shut down.

Individual control programs use multiple inputs to ensure that erroneous inputs do not produce incorrect output signals. This is achieved by rejecting:

- Analogue input values that are outside the expected signal range;
- Individual readings that differ significantly from their median, average or other reference.

A spare computer is provided as a source of spare parts for the station computers. It is also used for:

- Program assembly and checkout;
- Operator and maintainer training;
- Fault diagnosis in equipment removed from the station computers.

Computerized operator communication stations replace much of the conventional panel instrumentation in the control room. A number of human-machine communication stations, each essentially comprising a keyboard and colour cathode ray tube monitor, are located on the main control room panels. The displays provided on the monitors include:

- Graphic trends,
- Bar charts,
- Status displays,
- Pictorial displays,
- Historical trends.

Printed copies of the displays on any display monitor the operator wishes to record can be obtained from the line printers.

The digital computers are also used to perform the control and monitoring functions of the station and are designed to be:

- Capable of handling both normal and abnormal situations,
- Capable of automatically controlling the unit at startup and at any preselected power level within the normal loading range,
- Capable of automatically shutting down the unit if unsafe conditions arise,
- Tolerant of instrumentation failures.

The functions of the overall station control system are performed by control programs loaded into each of the two unit computers (Fig. 19). The major control function programs are:

- The reactor regulation program, which adjusts the reactivity control devices to maintain reactor power equal to its desired set point.
- The steam generator pressure program, which controls steam generator pressure to a constant set point by changing the reactor power set point (normal mode), or by adjusting the station loads (alternate mode).
- The steam generator level control program, which controls the feedwater valves in order to maintain the water level in the steam generators at a reactor power dependent level set point.
- The HTS pressure program, which controls the pressurizer steam bleed valves and heaters in order to maintain HTS pressure at a fixed set point.

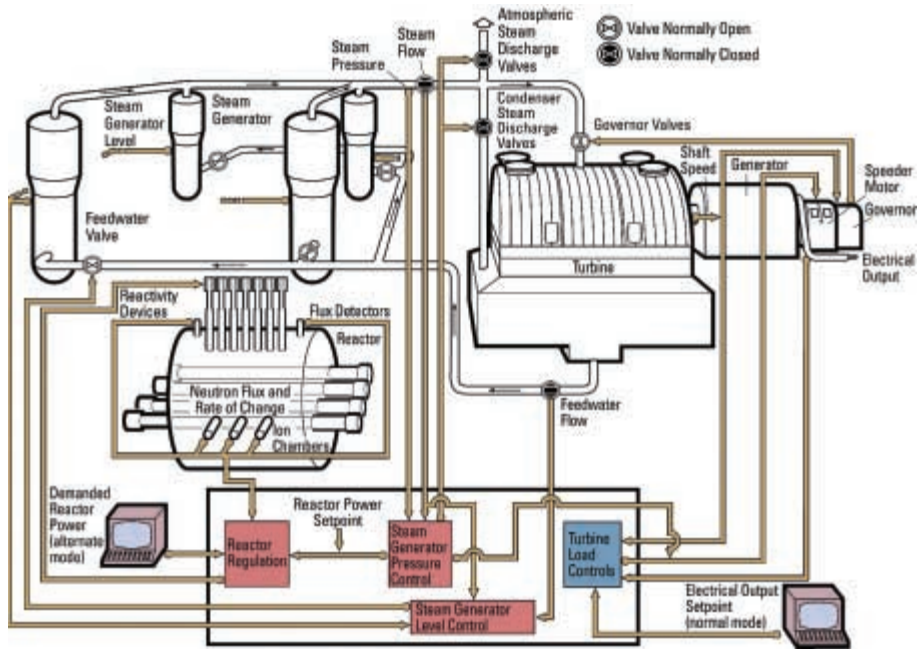

FIG. 19. Station instrumentation and control — modes.

There are also programs for:

- HTS control,
- Moderator temperature control,
- Turbine runup and monitoring,
- Fuel handling system control.

There are two modes of operation of the reactor: the ‘reactor following turbine’ mode and the ‘turbine following reactor’ mode.

In the reactor following turbine mode of operation, the turbine generator load is set by the operator: the steam generator pressure control program ‘requests’ variations be made to reactor power in order to maintain a constant steam generator pressure. This control mode is termed ‘reactor follows turbine’ or ‘reactor follows station loads’.

In the turbine following reactor control mode (i.e. turbine follows reactor), the station loads are made to follow the reactor output. This is achieved by the steam generator pressure control program, which adjusts the plant loads in order to maintain

a constant steam generator pressure. This mode is used at low reactor power levels, during startup or shutdown, when the steam generator pressure is insensitive to reactor power. It is also used in some upset conditions when it may not be desirable to manoeuvre reactor power.

3.1.5. Integrated 4-unit CANDU HWRs

CANDU features have been described previously with reference to CANDU 6. OH stations constitute the majority of operating CANDU plants and the Darlington/Bruce units are the reference plants for the CANDU 9 design. This section focuses not only on the differences between the stations, but on other features of their designs. OH has constructed five 4-unit stations which integrate many of the support services and system functions normally separated in single unit stations. Two of these stations (Pickering A and B) consist of 525 MW or 540 MW units, and the other three comprise 825 MW units (Bruce A and Bruce B) and 935 MW units (Darlington) [23]. These integrated 4-unit stations feature common control room area, emergency coolant injection, and electrical and service water systems. A summary of their differences follows.

3.1.5.1. Fuel channels

The fuel channels of the Pickering station are similar to those of the CANDU 6/9 and contain 12 bundles. The Bruce A and B, and Darlington stations differ in several respects:

- There are 480 channels in Bruce A/B and Darlington compared with 380 channels in CANDU 6/Pickering B.
- The Bruce/Darlington fuel channels contain 13 bundles with half of the bundle at each end out of the flux. The bundles are supported at the outlet end on a latch that bears on the outer rim of the outboard fuel bundle end plate. In the CANDU 6 channel, the fuel string is supported by the shield plug at the outlet end. The Bruce/Darlington design allows the channels to be fuelled from the outlet end, as opposed to the inlet end in the case of the CANDU 6 reactors.
- The Bruce/Darlington end fitting closure seals are based on a breech-block design.
- The Bruce A channels have one end welded to the end shield and the other welded to a positioning assembly.
- The Bruce B and Darlington channels have positioning assemblies at each end.

3.1.5.2. *Reactor assembly*

The Pickering A reactors have moderator dump as a shutdown mechanism in addition to mechanical shut-off rods. The Bruce/Darlington and Pickering B reactors have one shutdown system based upon the injection of poison (gadolinium) into the moderator (similar to CANDU 6/9) and mechanical shut-off rods. The shield tank arrangement in the Bruce/Darlington units comprises an octagonal steel tank filled with light water surrounding the reactor assembly, which is larger than the Pickering/CANDU 6 assembly. The CANDU 6 reactor has a concrete vault structure with a steel lining.

The Pickering A end shields contain steel slabs for shielding, whereas all the later units, such as the Bruce reactors, use steel balls.

The number and dimensions of reactivity control devices, shut-off mechanisms and instrumentation are larger than those employed with CANDU 6, consistent with the larger core [22].

3.1.5.3. *HTS*

The HTS in the Bruce units is characterized by having preheaters separate from the steam generators. In addition, in the Bruce A units, the steam generators are divided in two groups of four, each group being attached to a common steam drum on the secondary side. This design places limitations on heat-up and cooldown rates and has not been repeated. The steam generators in Bruce A and B are equipped with Inconel 600 tubing. Pickering units use Monel steam generator tubing. All other current units (Darlington and CANDU 6/9) use Incoloy 800. Each Bruce unit has six reactor headers, with two inlet headers and one common outlet header on each side (instead of separate outlet headers as are used in CANDU 6 units). The inlet feeders are connected to one of two inlet headers.

The Bruce units use a bleed condenser with low pressure, high temperature purification instead of a degasser–condenser with a high pressure, high temperature purification system (as is used in CANDU 6 units).

3.1.5.4. *Reactor plant*

The most significant features of the integrated plant are the common control room and the common fuelling machine duct that runs from reactor to reactor to enable fuelling machines to be interchangeable at each unit. In addition, the containment of each unit is connected to a large vacuum building by shafts and sealed with valves that can be opened after a severe system accident to draw radioactivity into the building.

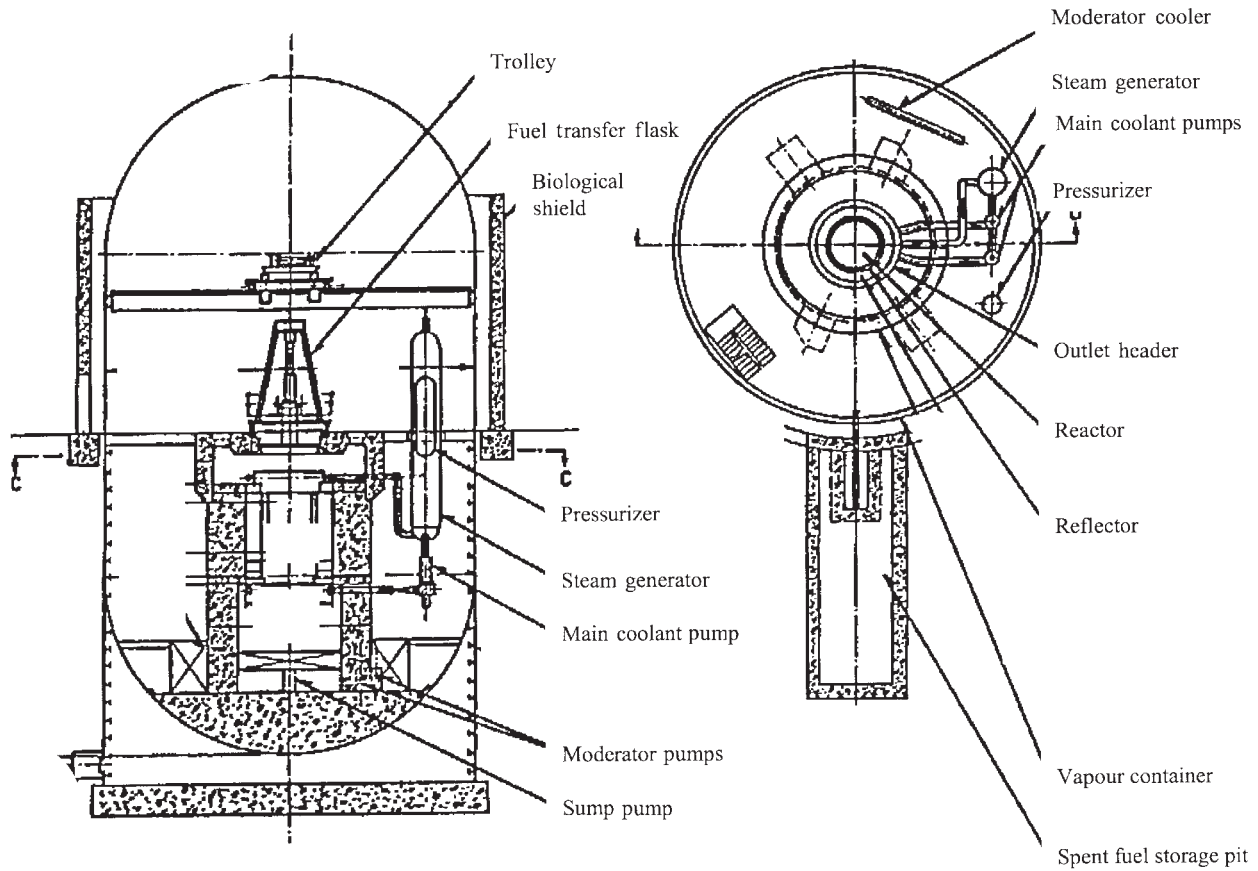

FIG. 20. Arrangement of components in the CVTR reactor building (vertical and horizontal sections).

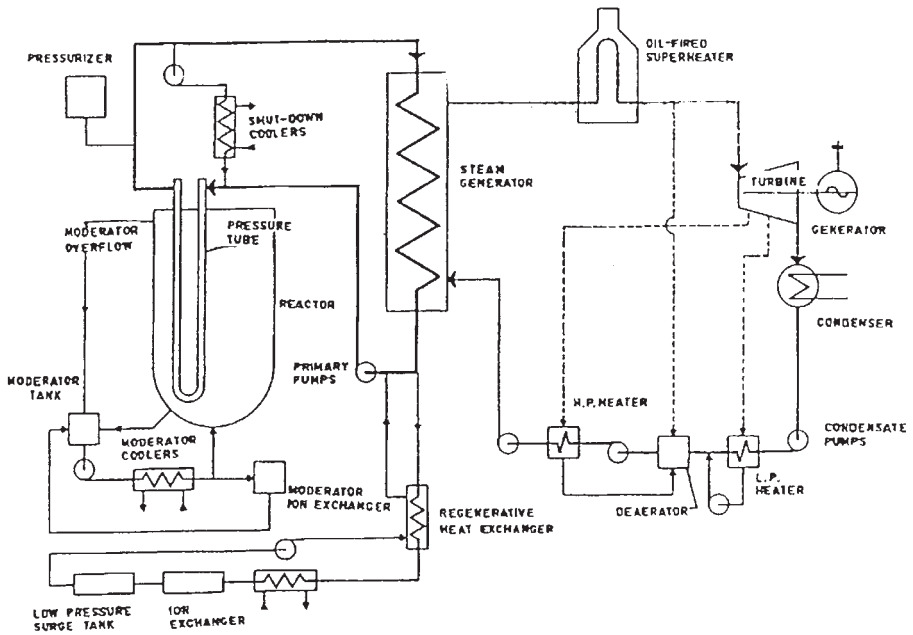

FIG. 21. Flow diagram of the CVTR circuits.

3.1.6. Carolinas-Virginia tube reactor (CVTR)

The CVTR heavy water cooled and moderated pressure tube reactor (Fig. 20) was built as a power demonstration reactor at Parr, South Carolina, USA. Construction started in 1960 and the reactor was completed and connected to the grid by the end of 1963 [24]. The CVTR generated 19 MW(e) and after about four years of operation, a planned experimental programme having been completed, it was shut down and eventually decommissioned [24, 25].

The reactor circuit contained many of the features of later pressurized heavy water cooled and moderated reactors, including a pressurizer, and significantly the balance of plant circuit incorporated an oil fired superheater to upgrade the quality of the steam being fed to the turbine (from the steam generator exit condition of 252°C and 42.5 kg/cm² to 385°C and 28 kg/cm² (Fig. 21)).

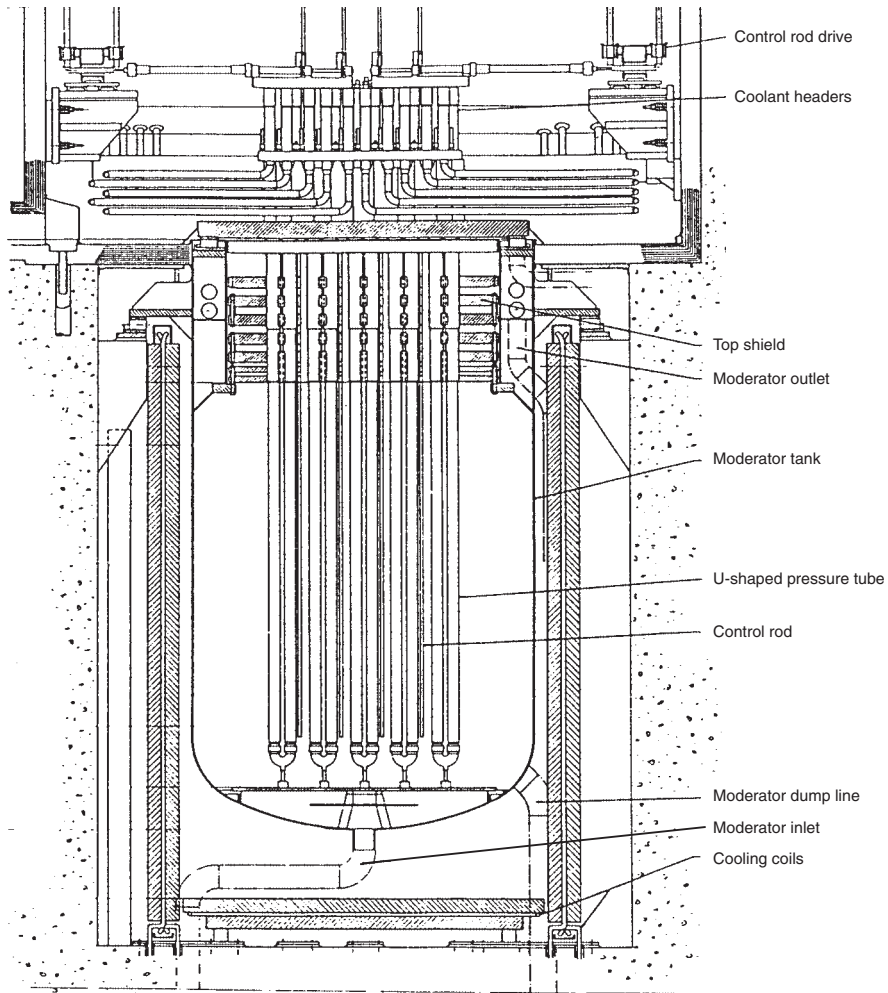

FIG. 22(a). Vertical section of the CVTR core.

The reactor assembly consisted of 36 U-tube fuel channels located on a rectangular pitch (16.51 cm × 20.32 cm) contained in an aluminium moderator tank (3.05 m diameter and 4.9 m high (Fig. 22)). The pressure tubes were of Zircaloy (0.61 cm wall thickness and 10.2 cm outside diameter), which operated with an inlet temperature of 275°C, an outlet temperature of 301°C, and at a pressure of 105.7 kg/cm². However, the pressure tube operated cold (i.e. at the temperature of the moderator water), and was insulated from the fuel coolant.

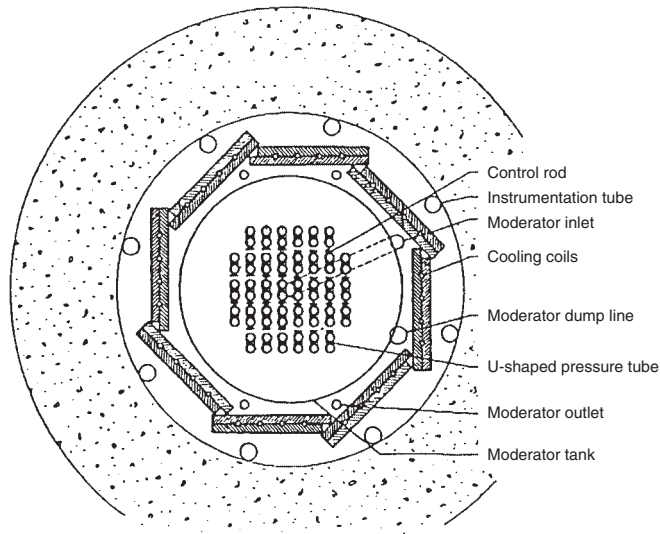

FIG. 22(b). Horizontal section of the CVTR core.

The HTS consisted of one loop which transferred the heated heavy water to an inverted U-tube steam generator containing 1600 tubes. The moderator heavy water was maintained at a temperature close to 68.5°C and near atmospheric pressure.

The reactor was controlled with stainless steel control rods (16) and shim safety rods of 1.5% boron steel (12 off). These rectangular cross-section rods ran vertically beside the fuel channels.

The reactor was fuelled with enriched uranium; one third of the channels containing fuel at 1.5% ^{235}U and two thirds at 2% ^{235}U . The fuel was clad with Zircaloy 2 sheathing (1.25 cm outside diameter and 0.58 mm wall thickness). The fuel pellets were 1.09 cm in diameter (Fig. 23).

As noted earlier, the reactor operated for four years without apparent problems and was shut down after that time when the operating information on the design had been obtained.

3.2. PRESSURE TUBE BOILING LIGHT WATER COOLANT, HEAVY WATER MODERATED REACTORS

3.2.1. Introduction

Four countries have evaluated the reactor system in which light water is brought to boiling in vertically oriented pressure tubes, the steam–water mixture being sent to

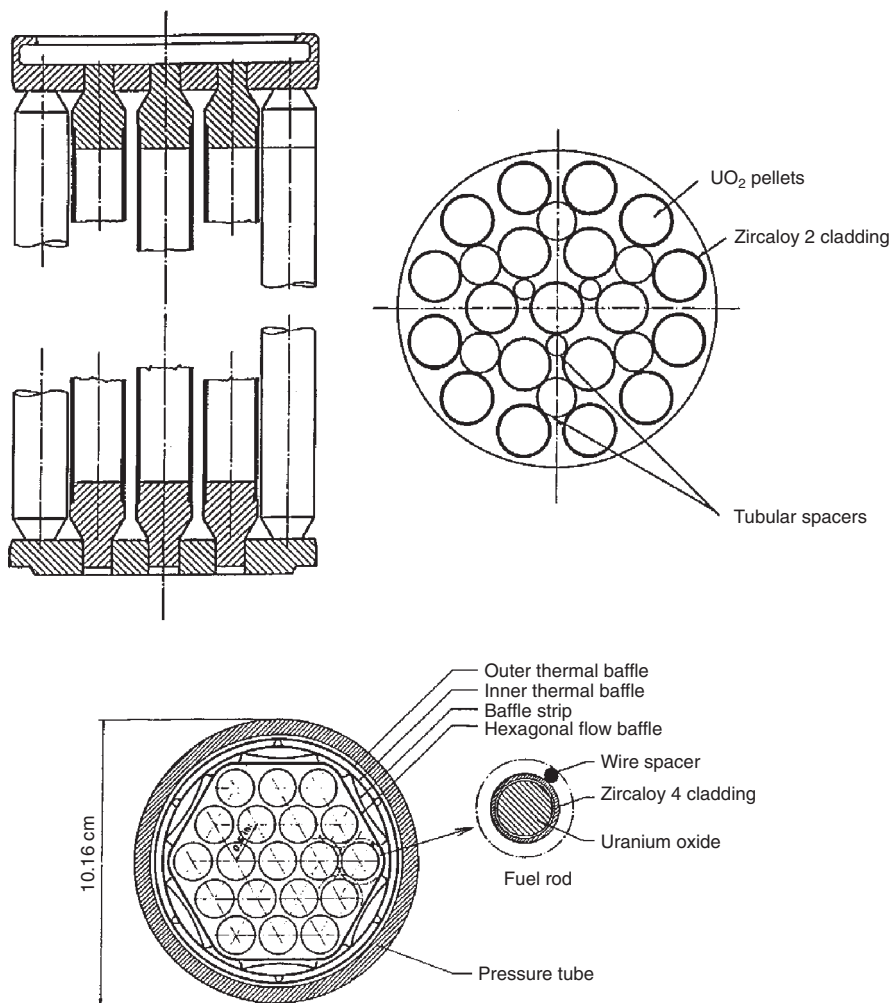

FIG. 23. Fuel assembly design (two versions) showing arrangement in the fuel channel.

steam drum separators and the steam used directly to drive a turbine. The arrangement simulates the conventional recirculation boiler. The Russian RBMK is a similar type of reactor, except that graphite is used as the moderator.

Each country had somewhat different reasons for initiating studies of this type of reactor. In the UK, there was a search for a more economic thermal reactor for electricity production than either the Magnox or the advanced gas cooled reactors, and one which would avoid the use of graphite as a moderator as well as the use of a

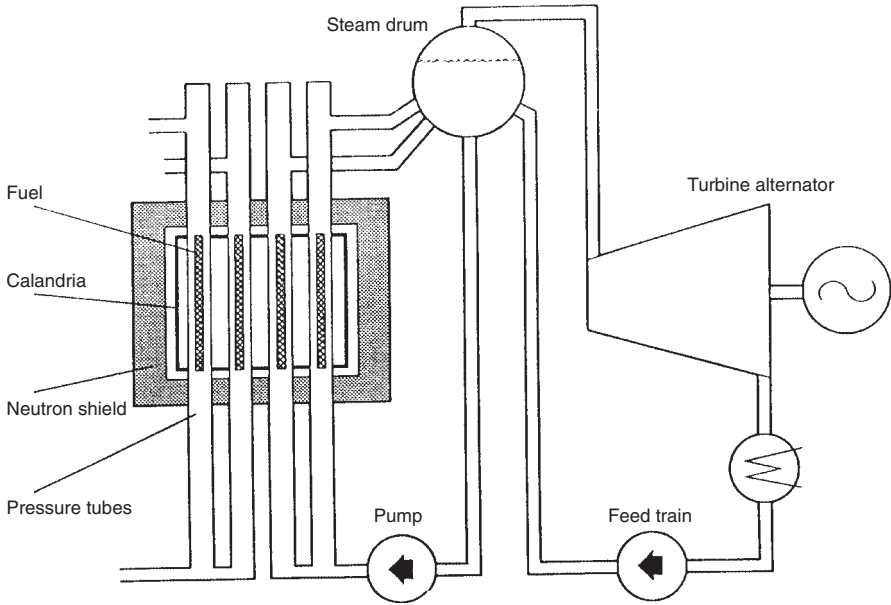

FIG. 24. The typical circuit for a boiling water cooled, heavy water moderated reactor.

large pressure vessel. Pressure vessel property changes during life and potential problems with resealing the vessel after refuelling were then current concerns. In Canada in the early 1960s, there was concern that the heavy water coolant system in the PHWRs would not be sufficiently leaktight to produce acceptable heavy water losses and there was a desire to develop a less capital intensive reactor by using light water coolant.

In Italy, the intention was to develop a reactor that was independent of enriched fuel, while in Japan the HWR was seen as part of a future fuel recycling strategy where spent fuel from PWRs would be recycled through HWRs in order to make use of the fissile material remaining in the fuel.

Thus, a prototype reactor was built in each country using the experience gained, which is described in subsequent sections.

3.2.2. General characteristics

Figure 24 shows the basic elements of a pressure tube boiling water heavy water moderated system [26]. The pressure tubes (vertically oriented) contain the fuel and the light water entering at the bottom of the fuel channel is brought to boiling,

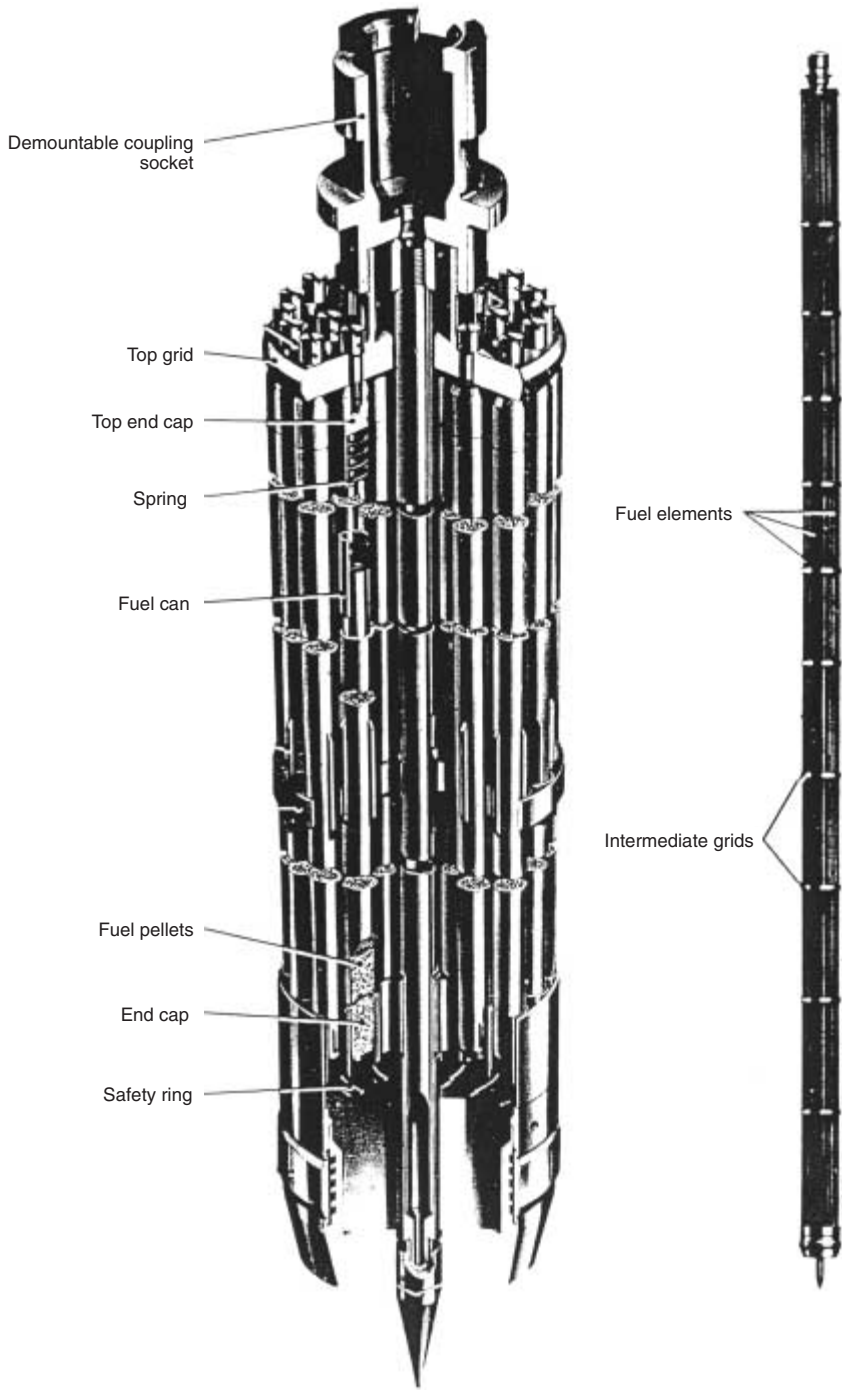

FIG. 25. Fuel bundle design used in the SGHWR.

about 10wt% of water being converted to steam. The steam–water mixture passes to the steam drums and virtually dry, saturated steam is supplied directly to the turbine. The exhaust steam is condensed and returned to the water space in the steam drums via a feed heating train.

3.2.3. The SGHWR

In 1963, construction started on the SGHWR at Winfrith in the UK. It was completed and started operation in January 1968 [5]. The reactor was designed for a power output of 100 MW(e), with 104 fuel channels containing 4 m long clusters of elements of low enriched UO_2 fuel. The original intention had been to use eight peripheral channels for supplying superheated steam, but these were never fuelled.

The fuel channels had Zircaloy 2 pressure tubes 130.5 mm in diameter and with a wall thickness of 5.08 mm, and aluminium alloy calandria tubes with an inside diameter of 184 mm and a wall thickness of 3.3 mm wall. The fuel channels were arranged on a square lattice pitch, 260 mm apart. The fuel bundles had 36 elements, each about 15.2 mm in diameter and with a wall thickness of 0.7 mm (Fig. 25).

The use of light water coolant and heavy water moderator means that with the choice of the appropriate fuel to moderator ratio, the void coefficient can be made to approach zero, and even be slightly negative.

Other core parameters are tabulated in the Appendix. The primary circuit flow diagram is shown in Fig. 26 and an isometric illustration of the reactor coolant and its circuit is shown in Fig. 27. The core is divided into two loops. The calandria which contained the moderator was made of aluminium–magnesium alloy.

Reactivity control and shutdown were achieved by: (i) varying the moderator height, (ii) injecting poison into absorber tubes, (iii) injecting boron poison into the bulk moderator, and (iv) operating with absorber in tubes in the moderator. Power trimming was accommodated by varying the moderator level; large reactivity changes from fuel burnup were balanced by removing boron from the moderator and xenon override achieved by moderator level adjustment and boron extraction. Load following was primarily accomplished by adjusting the moderator level and reducing the boron concentration. Power shaping was achieved by moderator displacement (or by use of borated liquid in absorber tubes) [27].

Power changes were initiated at the turbine throttle valve through the action of the turbine governor. Consequent steam pressure changes were then fed to a controller which varied reactor power by changing moderator height.

Emergency shutdown was effected by boric acid discharge into the moderator through liquid shutdown tubes, or achieved by moderator dump.

Refuelling on-power was effected from the top of the reactor. Access to the channels was through rotating shields (Fig. 28).

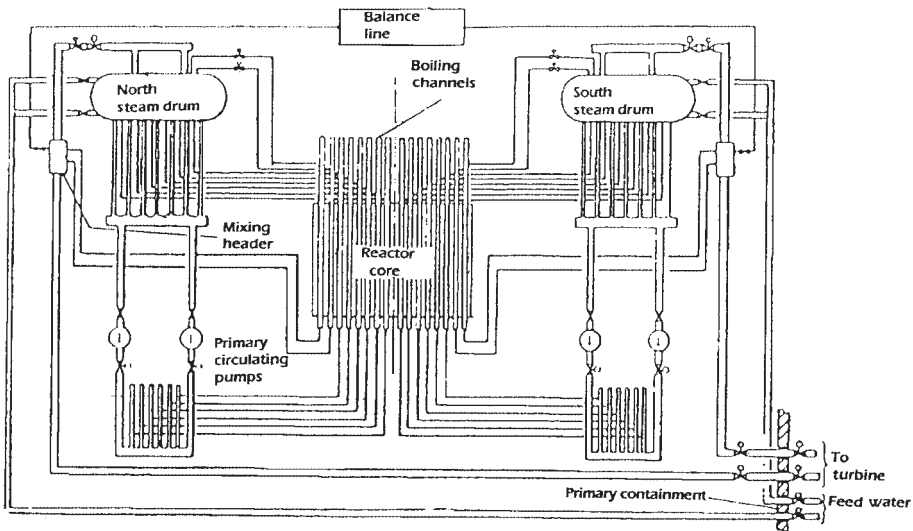

FIG. 26. Primary circuit arrangement for the SGHWR.

3.2.3.1. Operation

The Winfrith prototype SGHWR operated for 23 years at an average capacity factor of 60%. A commercial design for a 600 MW(e) reactor with 584 fuel channels was started but not completed before a review of the commercial SGHWR programme in 1976 concluded that the unit costs of early commercial SGHWR stations would make them uncompetitive. The programme was cancelled in 1977 [5].

Problems in early operation included heavy crud deposition on the fuel pins resulting from impurities in the coolant and cladding failures on the fuel. Contamination of the steam with ^{16}N produced by ^{16}O neutron-proton reactions in the core produced significant radiation fields around the turbine. Activated corrosion products resulting from the presence of ^{60}Co showed the need for reducing cobalt levels in the construction materials.

The reactor was used for many experimental investigations into water chemistry, fuel bundle design and heat transfer [28]. A loop through one of the fuel channels, independent of the main system, was used for heat transfer experiments, including dry out experiments. Extensive sampling points in the system (Fig. 29) enabled studies to be undertaken on model sources and the transport of corrosion products within the system. Fuel channels were inspected at intervals and, with periodic removal for evaluation, showed satisfactory rates of change with service,

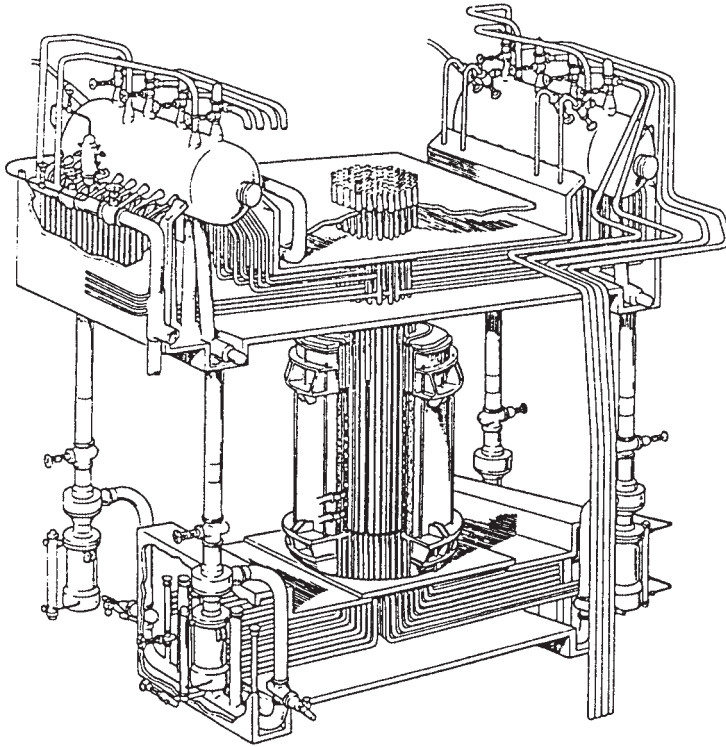

FIG. 27. Isometric illustration of the SGHWR.

particularly expansion and hydrogen pick-up in pressure tubes. However, the Zircaloy 2 pressure tubes, near the end of the operation, may have reached a phase of accelerated hydrogen pick-up behaviour.

3.2.4. Gentilly 1

3.2.4.1. Introduction

The Gentilly 1 pressure tube reactor was a 250 MW(e) heavy water moderated and boiling light water cooled design fuelled with natural uranium dioxide. The reactor concept had been developed in the early 1960s and in 1966 the reactor was committed for construction on the south bank of the St. Lawrence River, near Trois Rivières in Quebec. An illustration of the completed reactor building is shown in Fig. 30 and an

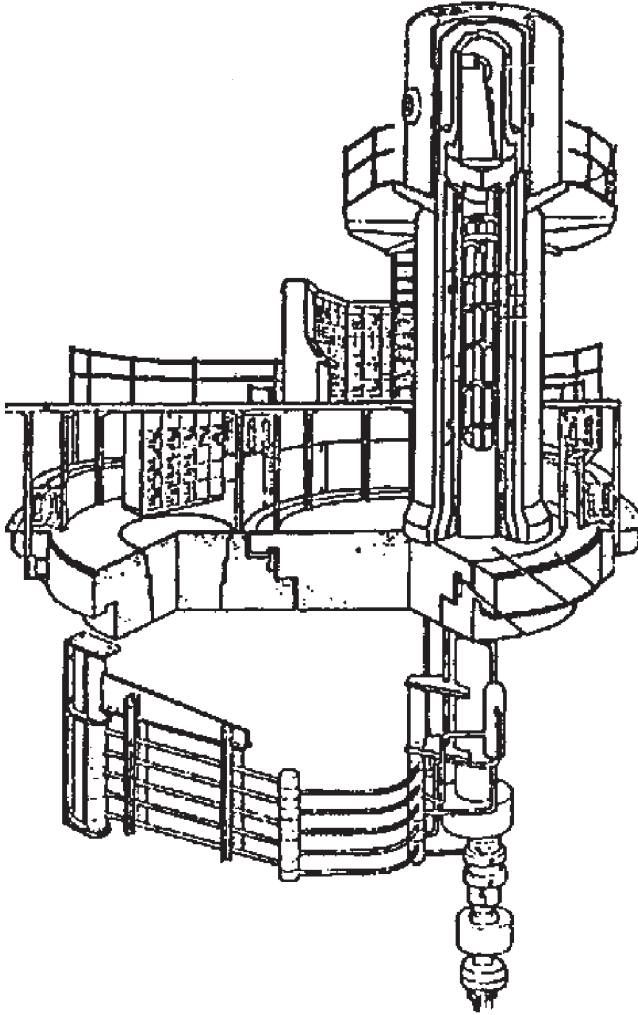

FIG. 28. Fuelling machine for the SGHWR.

illustration of the reactor assembly in Fig. 31. First power was produced in 1971 and full power attained in May 1972. It was shut down in April 1979 and by 1984 had been decommissioned [6].

3.2.4.2. Design

The 308 fuel channels were oriented vertically to permit development of the design to allow high coolant qualities. The fuel channels penetrated the vertical

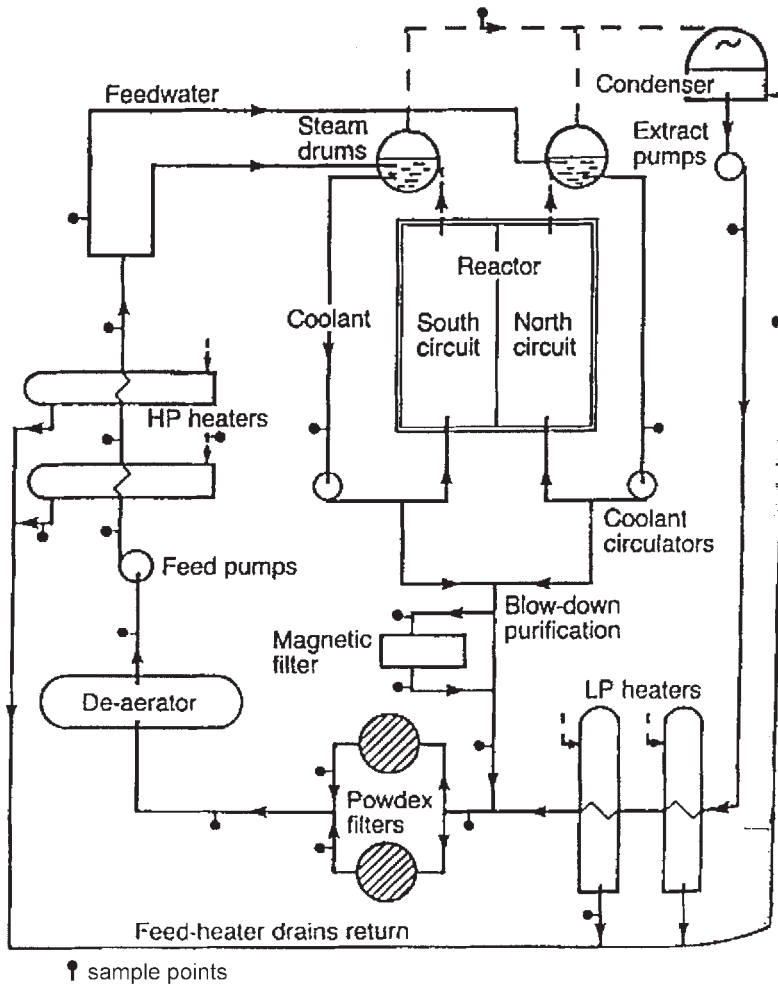

FIG. 29. Sampling points in the prototype SGHWR.

calandria which comprised three radially disposed zones (Fig. 32). The central zone comprised the reactor core and contained the pressure tubes and surrounding calandria tubes plus the heavy water moderator. The second zone contained only heavy water and served as a reflector. The third zone was the dump annulus which surrounded the second zone and which was separated from it by a radial baffle plate. The third zone was connected hydraulically to the two inner zones by a radial dump port located at the bottom of the baffle. During operation, helium gas pressure in the dump annulus prevented heavy water in the two inner zones from flowing into the dump annulus. Rapid equalization of the helium gas pressure in the spaces above the

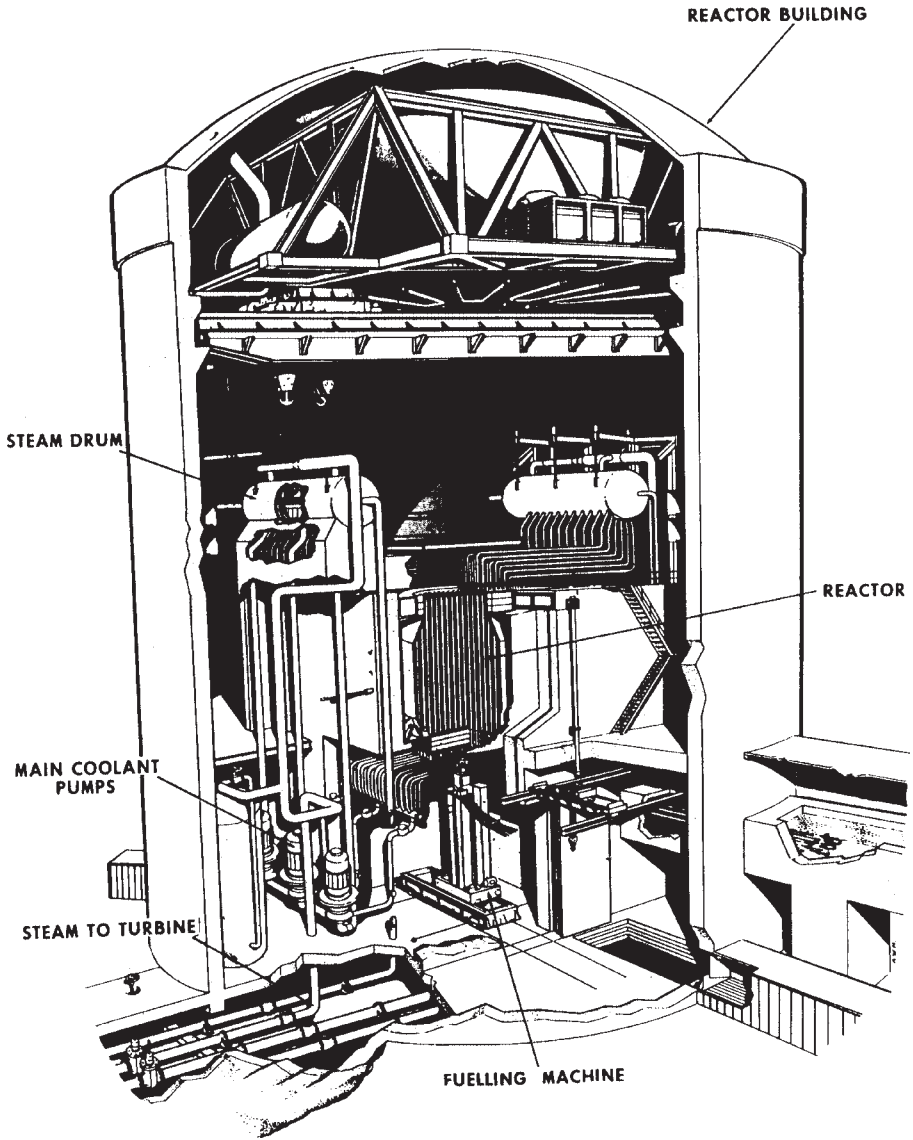

FIG. 30. Cutaway drawing of the Gentilly 1 reactor building.

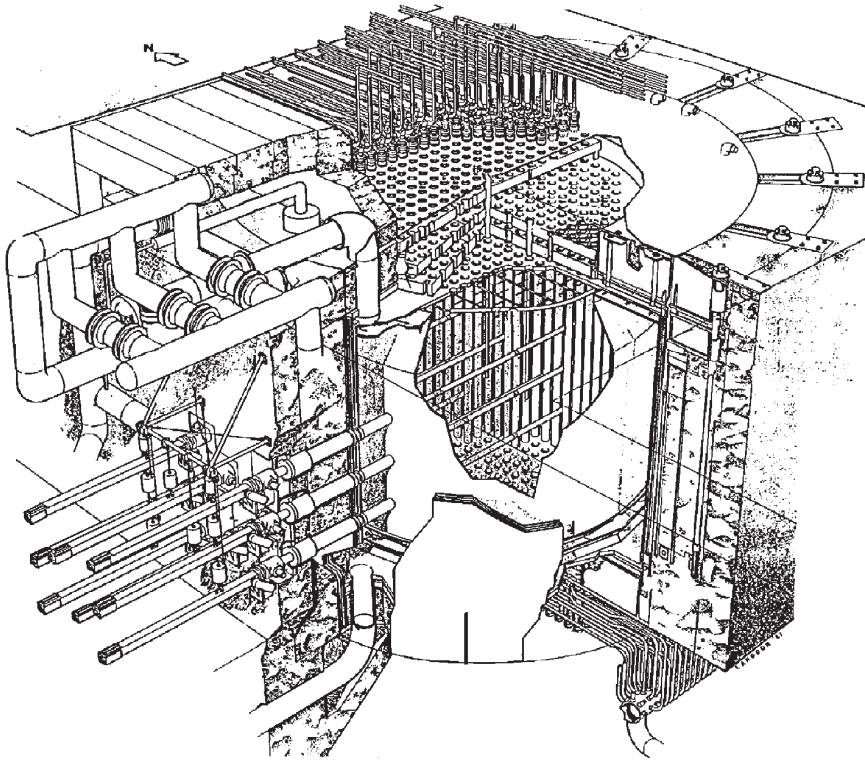

FIG. 31. *Gentilly 1, boiling light water; heavy water moderated reactor assembly.*

three zones permitted the heavy water to flow rapidly into the dump annulus and then into a dump tank, thereby shutting down the reactor.

The fuel design chosen comprised an 18 element 0.5 m long bundle of similar design to that of CANDU PHWR fuel, except that the fuel pins were larger in diameter (19.7 mm as opposed to 15 mm), and the sheath was thicker (0.49 mm compared with 0.38 mm) in order to improve the uranium dioxide: zirconium ratio. The fuel pin spacing was less than in PHWR fuel so as to reduce the amount of light water in the channel. There were 10 bundles in each fuel channel. The bundles were mounted on a central structural tube to facilitate handling and limit vibration in the pressure tube. However, these features reduced the power output by 20% compared with PHWR channels. The fuel in general performed as expected, achieving burnups of 180 MW·h/kg U.

Control and instrumentation features generally followed the practices being employed in the CANDU PHWR reactor designs. The positive void coefficient and power coefficient of reactivity in the reactor were offset by the large time constant

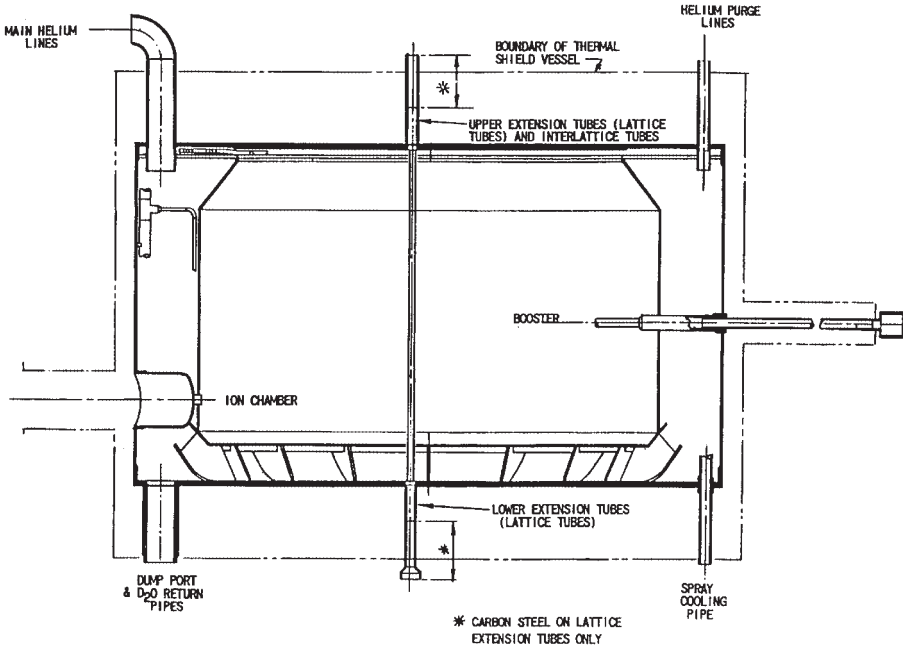

FIG. 32. Boundary of the calandria vessel.

(15–20 s) associated with the large UO_2 fuel rods which delayed the formation of voids following a change in reactor power. This delay exceeded any expected in the reactor control system. Thus, the control system was able to respond to any change in reactor power in advance of steam formation effects.

Reactivity control was achieved by:

- On-power refuelling, which was from the bottom of the reactor only, using a single fuelling machine. The fuelling machine could transfer the fuel string to a water filled trench in the service building for fuel shuffling in order to optimize burnup and return a shuffled fuel string to the channel.
- Adjustment of flux distribution using zonal absorbers (7 off) distributed throughout the core to achieve maximum output and to act as a control loop for reactor flux.
- Moderator poison injection (boron) which could be made to compensate for absence of xenon on initial startup or startup after a long shutdown.
- Variation in coolant flow, within limits, to control the average core coolant density.

- Booster rods, which could be employed to compensate for the absence of voiding on startup and operation at low power levels.

These features are shown in Fig. 33. Safety systems to shut down the reactor consisted of moderator dump (the moderator level was not normally employed to control reactor power) and a liquid injection system (gadolinium nitrate) into the moderator.

The reactor HTS operated at a pressure of 7.7 MPa. The water entered the pressure tube at 267°C and exited at 290°C at 20% quality. The HTS was made of carbon steel except for the 2.25%Cr–1%Mo outlet feeders. The pressure tubes were made of heat treated (quenched and aged) Zr–2.5%Nb and because the system pressure was relatively low, the pressure tubes (103.5 mm inside diameter) were only required to have a wall thickness of 2.41 mm. The HTS is shown in Fig. 34.

The balance of plant was along the lines of a conventional BWR plant circuit.

3.2.4.3. Operation

The operation of the reactor suffered from difficult control problems. Even at constant power it was nearly impossible to keep a constant steam quality in each channel, and the local fuel power increased, driving the local steam quality higher because of the positive void coefficient.

In order to accommodate the resultant changes in spatial flux shape, it was essential to have a spatial flux control system based on having a sufficient number of absorber rods in the core. However, the designed rods were located too close to the centre of the core which resulted in insufficient control being exercised in the outer regions, thereby causing flux tilts during booster rod insertion.

It was recognized that enriched fuel would not have placed a high premium on neutron economy and would have allowed the use of higher channel power, tighter lattice pitch, and higher burnup.

The basic reason underlying the decision to shut down Gentilly 1 was the early highly successful operation of the CANDU PHWR Pickering A units. These went into operation in 1971–1973 and decreased the need for a backup design should heavy water losses be unacceptable in the PHWR, as they were at Douglas Point.

While the early operation of Gentilly 1 was generally successful, the flux tilts already described and the corrosion problems resulting from the decreased quality of the river water, as well as problems with fuel channel closure plug seat spalling and fretting of pressure tubes by flux suppressors, had to be resolved. The estimated cost of resolving these problems could not be justified by AECL (which owned the plant, although Hydro Quebec operated it), in terms of reactor development priorities and the lack of purpose for the reactor, when Hydro Quebec decided to build the Gentilly 2 PHWR.

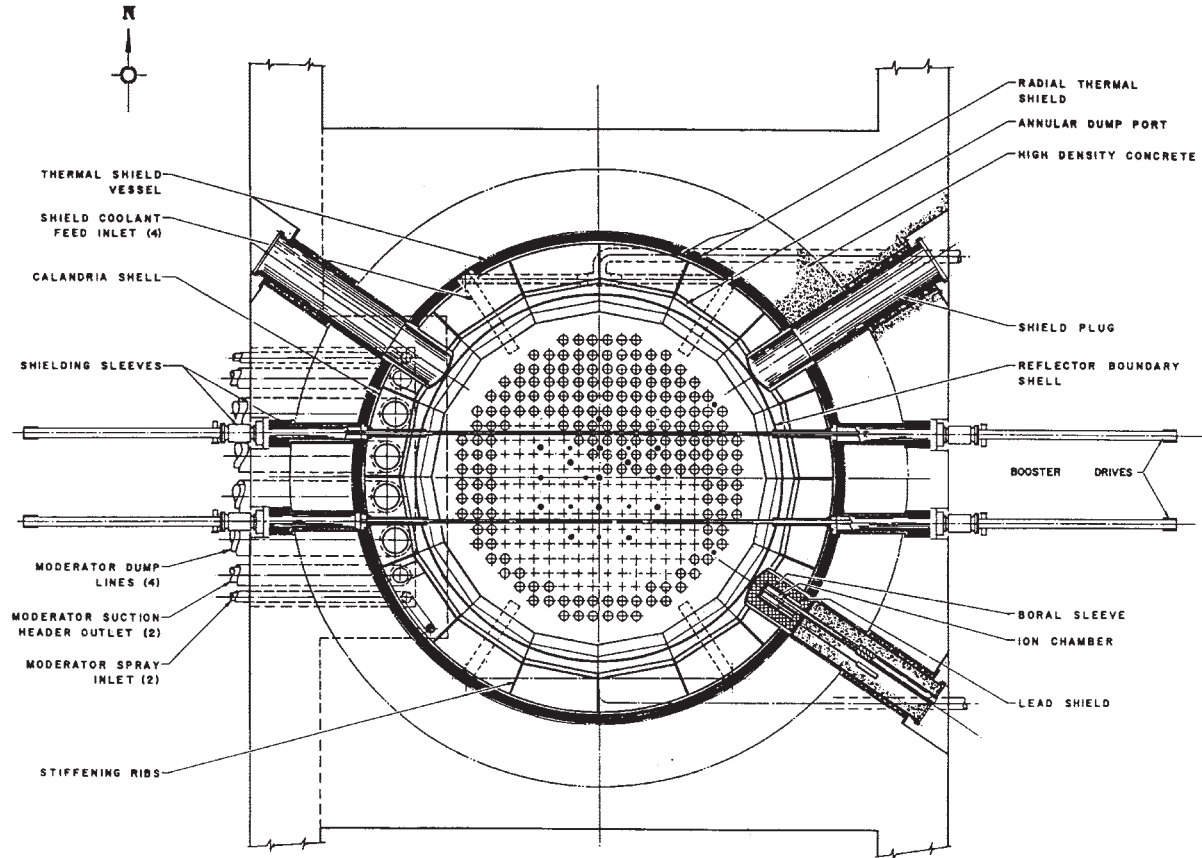

FIG. 33. Arrangement of boosters and ion chambers.

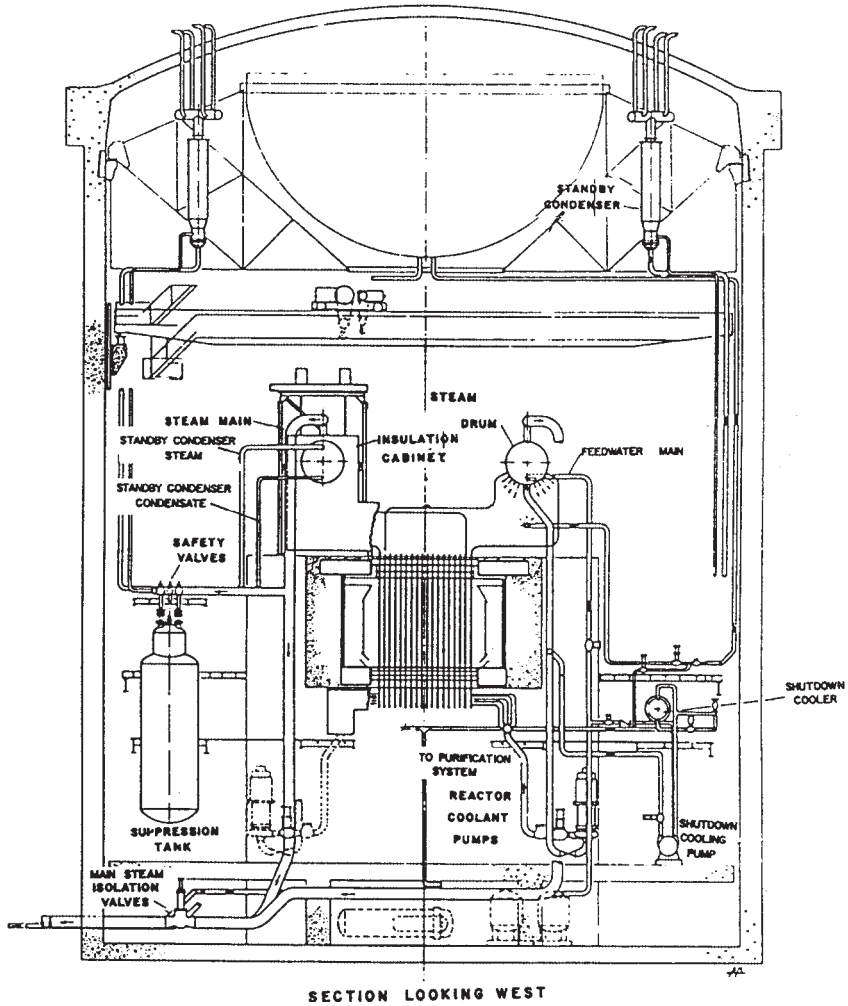

FIG. 34. Arrangement of the Gentilly 1 HTS.

3.2.4.4. Comment

The major factors which suggest that the boiling light water version of CANDU should be economically attractive are obvious. These include: elimination of expensive heavy water as the reactor coolant, elimination of those systems necessary

for the recovery and upgrading of heavy water that has leaked from the reactor coolant system, elimination of the heat exchanger portions of the steam generators, and improved thermodynamic efficiency available from the higher turbine cycle steam pressure through use of a direct steam cycle.

Offsetting these advantages are a number of factors which are not, perhaps, as immediately obvious. These centre on the reactor core design and result from the relatively high neutron absorption of the light water coolant. Boiling of the light water coolant in the core reduces the effective density of the coolant, thereby reducing the neutron losses — except during startup — a consideration which will be discussed later. There is, however, a practical limit of the degree to which coolant density reduction can be achieved through boiling and this is dictated by the need to avoid dry out of the fuel sheaths. Greater degrees of boiling reduce the margins to dry out for a given fuel power rating. Another way to reduce the neutron absorption of the coolant is to decrease the coolant flow area through the fuel bundles by increasing the cross-sectional area of the fuel for a given pressure tube diameter. In the case of the Gentilly 1 reactor, this was done by adopting a 19 element fuel bundle geometry with the standard CANDU 10 cm pressure tube. This, however, limits the available fuel channel power, since the linear heat rating of the fuel elements must be such as to avoid centre line melting of the fuel.

As a result, a greater number of fuel channels is required relative to the CANDU PHWR design, which increases the necessary heavy water moderator inventory and total fuel channel costs, particularly the end fitting and lattice tube costs. The relative fuel channel costs are further increased by the fact that the optimum length of the fuel channels is significantly shorter because of dry out considerations with the boiling coolant (4.5–5 m compared with the 6 m channel length used for the CANDU PHWR).

A further important cost consideration involves the need to provide additional reactivity in order to permit a reactor restart following a trip when boiling in the fuel channels ceases, resulting in an additional significant reactivity load. In the case of Gentilly 1, this additional reactivity was provided by a number of highly enriched moderator cooled booster rods which could be inserted into the core for restart. Unfortunately, the use of these booster rods caused major flux distortions in the core which, in practice, could not be compensated for by the regional flux control system. As a result, Gentilly 1 could only be restarted after the xenon poison transient had effectively died out, thereby providing the needed additional reactivity. This imposed a major delay in restarting after a trip. This problem could likely be overcome by employing a new design comprising a larger number of smaller worth booster rods and additional regional flux controllers. However, this would entail incurring significant additional capital costs.

Further unique costs associated with the CANDU BLWR are incurred through;

- (i) the need to provide shielding for the direct cycle turbine and its feedwater train,

(ii) the need to provide an active turbine condenser off-gas system, and (iii) the need to provide a separate dump condenser to act as a transient heat sink on loss of availability of the turbine plant (direct steam discharge into the atmosphere is precluded since the steam is radioactive).

In summary, AECL studies of commercial scale CANDU BLWRs indicated that a modest economic advantage in favour of this type, relative to CANDU PHWRs, might be realized (perhaps up to a maximum of 10%), but that given the uncertainties associated with the relatively unproven design and the need for extensive development work, particularly in the safety area, this indicated advantage was not sufficient to justify further development of the reactor type [29].

3.2.5. Fugen

3.2.5.1. Introduction

The 165 MW(e) Fugen reactor was the prototype of what was to be a line of 600 MW(e) reactors that would form part, in conjunction with LWRs, of the Japanese fuel recycling strategy. Such plants would use various fuels containing recycled plutonium, depleted uranium and enriched uranium [30]. The 600 MW(e) demonstration plant was designed but not built because the project had become too costly and MOX fuel cycles were established for LWRs.

The Fugen project started in October 1967. Site construction at Tsuruga began in December 1970, and the plant went into operation in March 1979.

3.2.5.2. Design features

A schematic flow diagram of the reactor circuits is shown in Fig. 35 [31]. The reactor has two independent cooling circuits, each consisting of a steam drum, inlet header, two recirculation pumps and associated pipes (Fig. 36).

Each of the 224 vertical fuel channels has a heat treated Zr-2.5%Nb pressure tube into which is loaded a cluster fuel string assembly consisting of 28 Zircaloy 2 clad fuel elements (Fig. 37). The fuel is loaded from the bottom of the reactor, off-power, although the system was designed for on-power refuelling.

The reactor operated with MOX fuel at a near zero positive void coefficient. The void coefficient could be made more negative by adjusting the concentration of plutonium in the fuel. Fuel of different compositions were used in the channels to flatten the flux distribution [8].

Core reactivity is controlled by 49 motor driven control rods and a control system for regulating concentrations of boron in the moderator.

The reactor thermal power is controlled in order to maintain the rated electric power. The electrohydraulic control system regulates the turbine control valves in

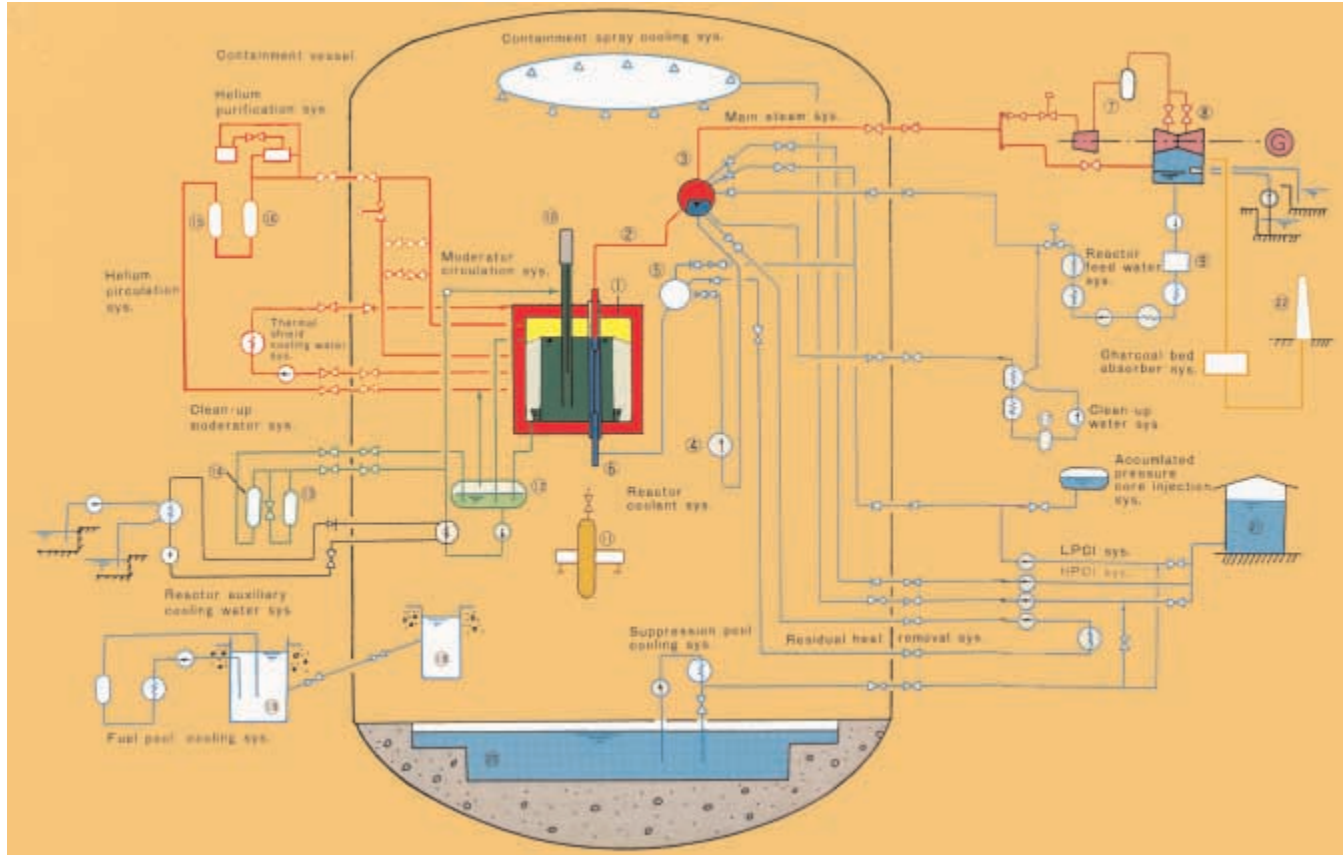

FIG. 35. Schematic flow diagram of the Fugen reactor.

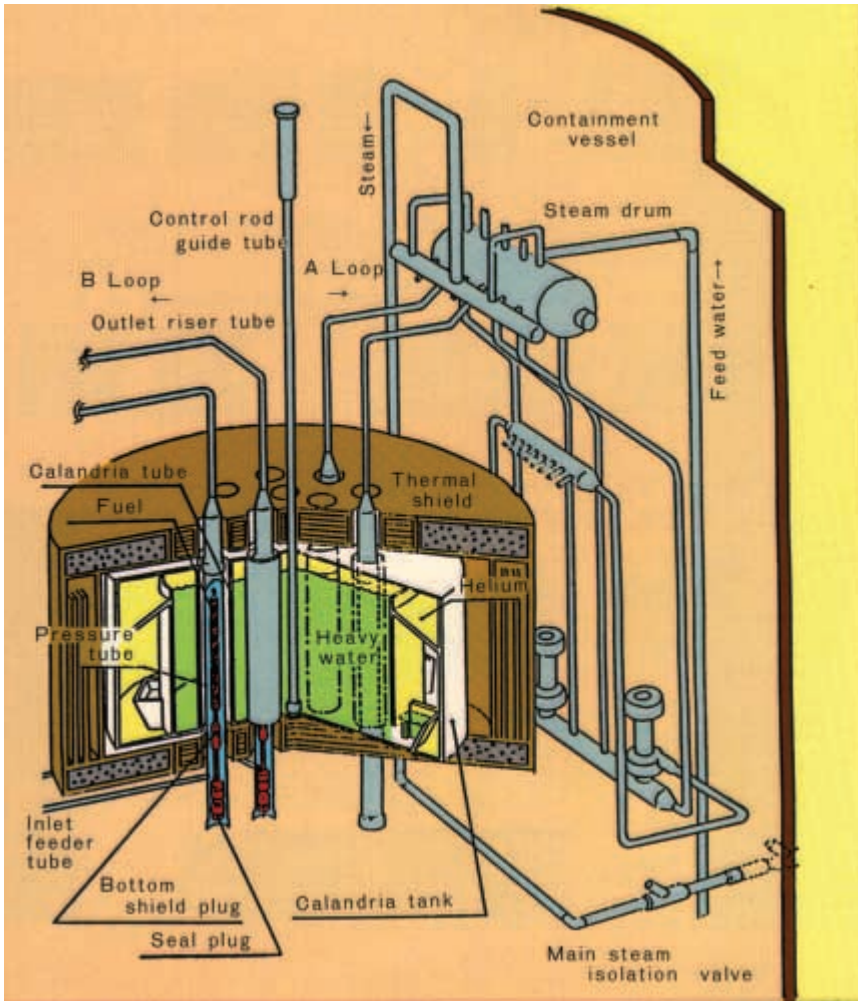

FIG. 36. Fugen reactor core and reactor coolant system (vertical).

order to maintain constant steam pressure and turbine speed. The water level in the steam drum is controlled by a three element controller fed with signals from the main steam flow, the feedwater flow and the steam drum level.

3.2.5.3. Operation

The reactor has operated with an overall capacity factor of approximately 64% since startup. The MOX fuel has performed very well and has achieved a maximum burnup of 14 000 MW·d/t without the fuel defecting.

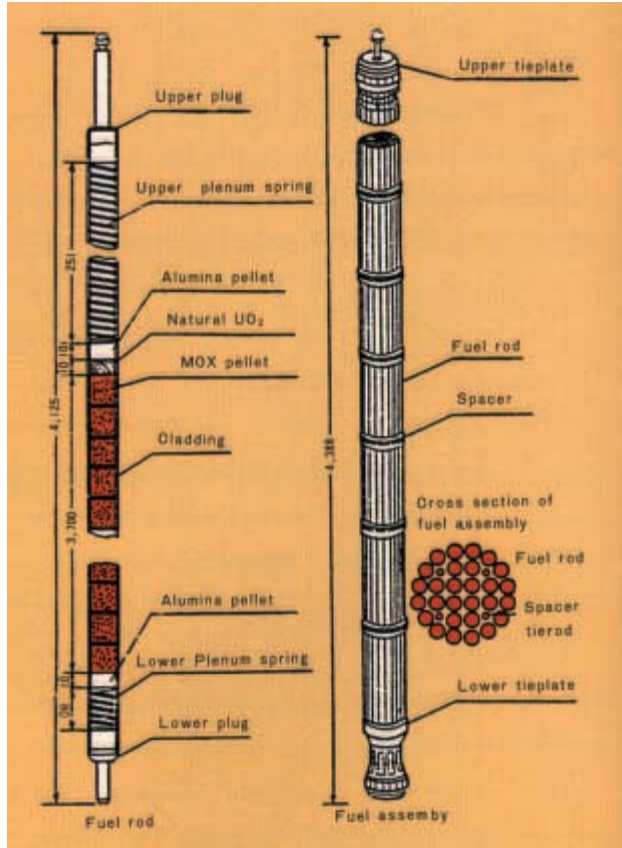

FIG. 37. Fugen standard fuel assembly.

3.2.6. Cirene

3.2.6.1. Introduction

The Cirene reactor was a 40 MW(e) prototype power plant constructed at Latina, 80 km south of Rome. Construction started in 1976 and completion was scheduled for 1984. It was to serve as a vehicle to help consolidate the various nuclear organizations in Italy by providing a focus for activity and, when operational, function as an experimental facility for advanced R&D work. However, work on commissioning stopped in 1988 when the Italian Nuclear Regulatory Authority would

not issue an operating licence on the grounds that Cirene's positive power coefficient, generated by a large positive void reactivity coefficient, did not match the current safety standards, although this had been fully acknowledged and addressed in the design [32]. Techniques to reduce the positive reactivity to low positive or negative levels through fuel enrichment and the use of absorbers, cobalt in the central structural tube and dysprosium in the fuel, had not been accepted when the project closed down because of the general moratorium on nuclear reactor operation imposed by the Italian Government following the Chernobyl accident.

3.2.6.2. Design

The Cirene reactor consisted of 60 vertical channels (arranged on a 27 cm square pitch) penetrating a 3.69 m diameter vertical calandria 4.7 m high [24]. The core had an active height of 4 m, plus top and bottom reflectors (Fig. 38).

Each pressure tube contained 8 fuel bundles, each bundle containing 18 elements arranged in two rings of 12 and 6 elements, supported on a central structural tube (Fig. 39). The inner 36 channels were to be fuelled with natural uranium (UO_2) and the outer 24 channels with 1.15% enriched uranium.

The reactor calandria was made up of two, thin concentric shells and two shell plates at its upper and lower ends connected to each other by the inner shell and the calandria tube extensions. The two concentric shells encased two volumes: the core tank and the dump annulus. The two volumes contained the heavy water and cover gas, and were connected by a wide annular port in the lower part of the core.

The coolant flow rate was designed to match the reactor power level, such that the average coolant density was to be maintained at a constant value with an average exit quality at full power of 26%. At less than 30% power on startup, steam was injected into the inlet feeders from auxiliary boilers via a steam compressor.

Reactivity control was achieved by continuously varying the mixture density within certain specified limits using four two-phase control rods containing a mixture of oxygen and borated water [4]. The mixture flowed through Zircaloy U-tubes arranged vertically in the core between the channels. Moderator level changes and coolant flow rate changes supplemented the control rod capability if necessary. Boron concentration in the moderator compensated for fuel burnup and excess reactivity on initial startup.

Protection against LOCAs provoking coolant voiding (attaining ~30 mk for the whole core voiding) was provided by two independent shutdown systems: moderator dump to achieve 60 mk negative reactivity in approximately 3 s, initiated by 3 out of core ion chambers; and 10 liquid poison shut-off rods providing -110 mk in about 1.2 s, initiated by 12 in-core detectors that caused fast acting valves to open.

The balance of plant for the Cirene reactor followed the conventional design for boiling water.

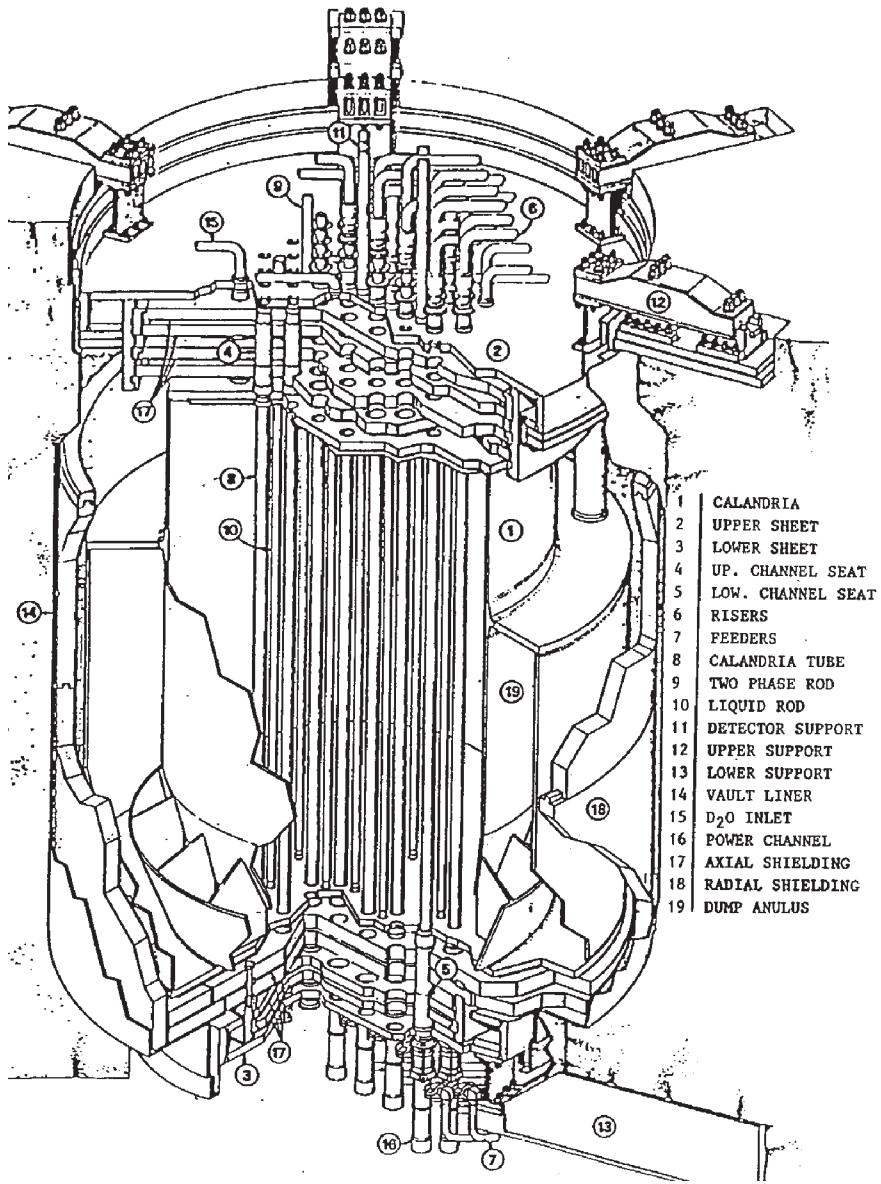

FIG. 38. Cirene reactor assembly.

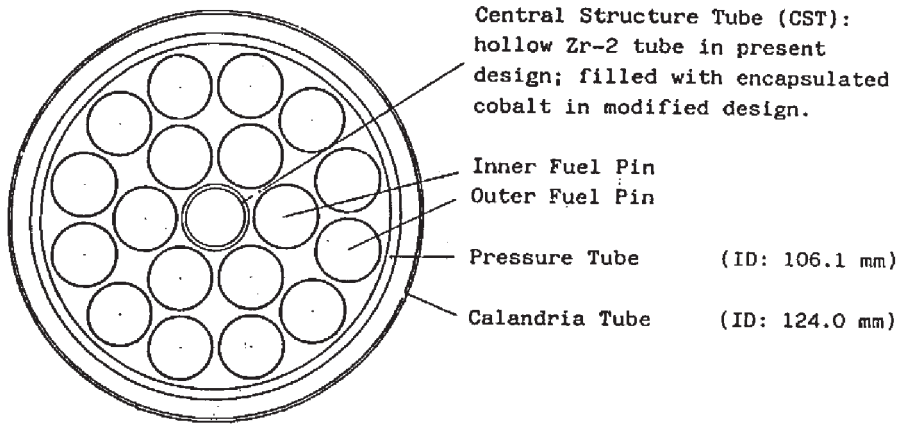

FIG. 39. Cross-section of a Cirene fuel bundle.

3.2.7. Summary

The comments given in Section 3.2.4.4 can be applied generally to this line of reactors. The use of light water coolant, dispensing with steam generators, is economically attractive. These advantages have been offset by necessary design modifications in the fuel and other features, and by a necessary increase in the number of channels needed to achieve the same output as pressurized PHWR versions.

However, provided these problems are addressed in revised designs, this line of reactors should be cheaper to build and to operate than the heavy water cooled versions. As described in Section 8, a conceptual design for a reactor which uses plutonium and thorium fuel is being pursued by India as part of its overall plan for nuclear based electricity generation.

3.3. CHARACTERISTICS OF A PRESSURE VESSEL PHWR

3.3.1. Introduction

HWRs of the pressure vessel type have been designed and constructed in three countries: Sweden, Germany and Argentina. The main references of this line are: the Ågesta reactor in Sweden (shutdown), the MZFR reactor in Germany (shutdown),

and the Atucha 1 (in operation) and Atucha 2 (under construction) reactors in Argentina.

3.3.1.1. Sweden

In Sweden, the first pressure vessel pressurized HWR was constructed at Ägesta [9, 33–35]. This was a project that combined the objectives of two separate reactor concepts: one for a district heating reactor and the other for a heat and power reactor. The pressure vessel reactor was conceived as a 65 MW prototype plant that was to supply district heating and electricity (10 MW(e)). The reactor was designed by the Swedish Atomic Energy Company with ASEA as the major contractor. The reactor was located in an underground chamber excavated in solid rock and serviced a suburb of Stockholm.

The reactor vessel was a cylinder, 5 m in diameter and 6 m high. The top head consisted of two flat plates separated by a grid of stiffening webs with the interspace filled with light water and kept at a temperature similar to that of the adjacent pressurized heavy water by a special heating circuit. The top head was pierced with fuel ports and openings for control rod thimbles and for connections to the pressurizer. The bottom was dished and penetrated by four inlet nozzles and four outlet nozzles (Fig. 40) [36].

The reactor core consisted of 140 fuel channels or shroud tubes of Zircaloy 2 arranged on a 27 cm square lattice pitch, each containing a fuel assembly consisting of four bundles joined together to form a 3 m long assembly. Each bundle contained 19 fuel elements (Fig. 41). The shroud tubes were connected to the ports of the distribution header.

The heavy water from the steam generators entered the inlet nozzles at 205°C and was heated to 220°C in passing up the fuel strings in the shroud tubes. At the top of the shroud tubes, the water was returned down through the tube matrix to the outlet nozzles and then to the ‘hairpin’ type steam generators.

Control rods were vertically oriented and spaced between the shroud tubes as shown in Fig. 42. The control rods numbered 30, of which 16 were fast acting rods of stainless steel clad over silver–cadmium alloy. A boron injection system was also added as a fast shutdown mechanism.

The reactor was shut down for refuelling. Each fuel port in the head serviced three or four channels. The fuelling machine, mounted above the reactor, either removed the fuel string or replaced it or ‘shuffled’ it for increased burnup, which was normally at a level of 4000 MW·d/t.

The reactor operated with a good degree of reliability. Operation was interrupted over the summer months when district heating was not required. The reactor was shut down in 1975 and decommissioned because it had ceased to be an economic source of power.

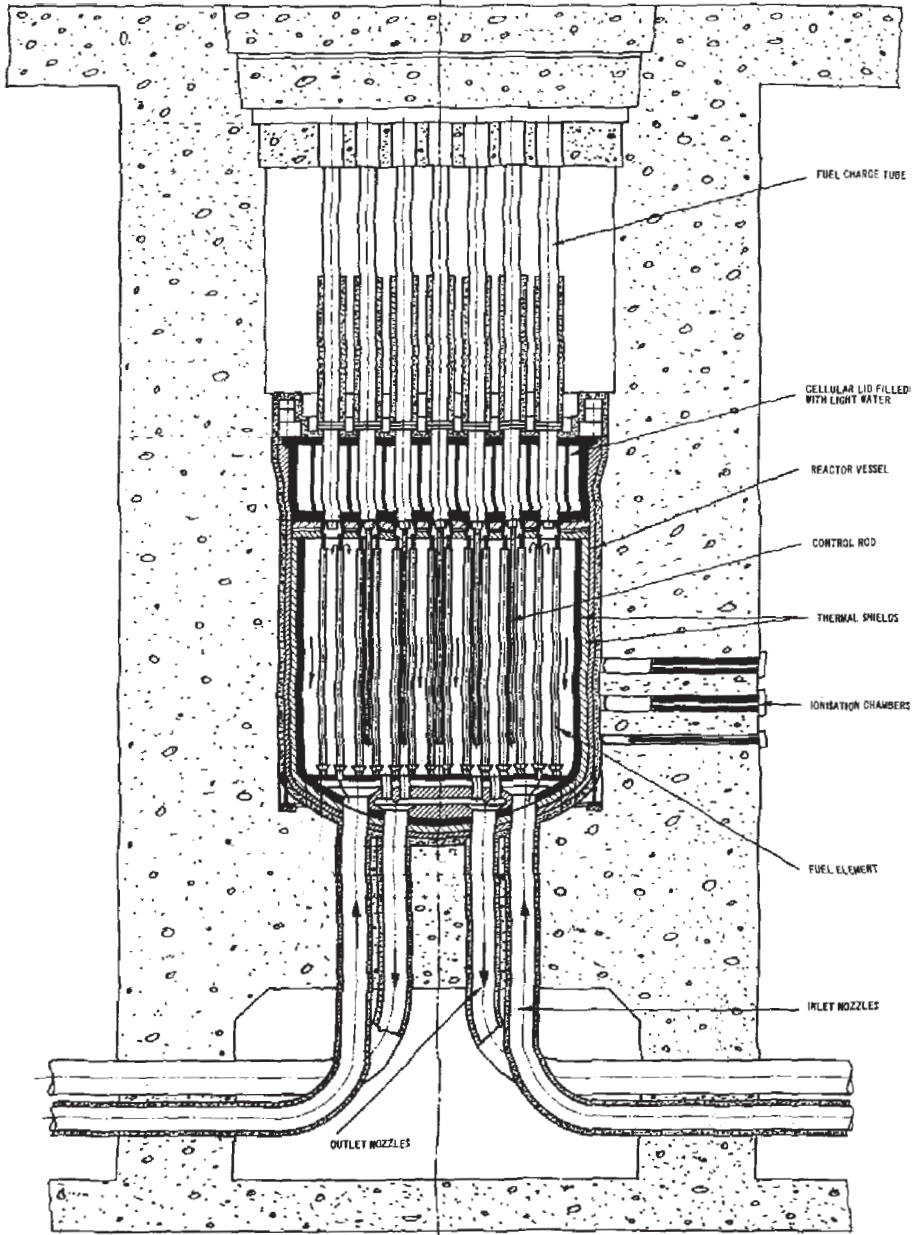

FIG. 40. Vertical section through Sweden's Ågesta reactor.

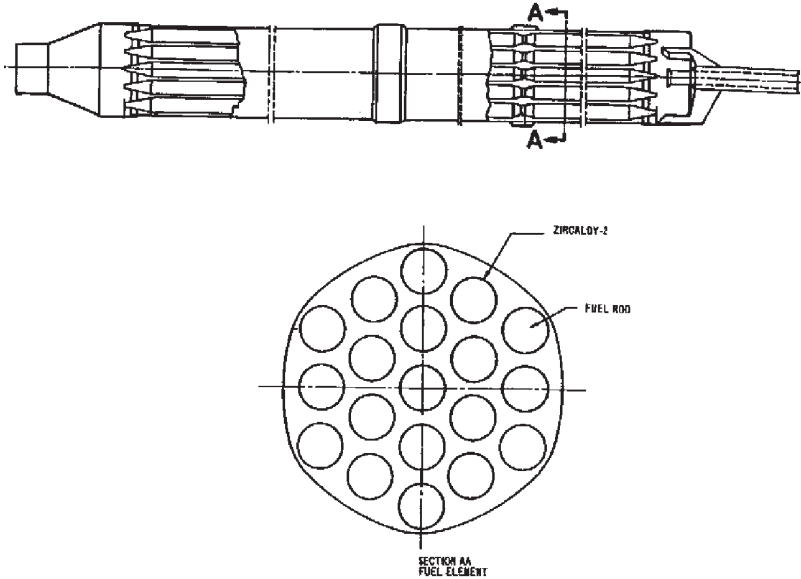

FIG. 41. Longitudinal and transverse sections through the 3 m long fuel bundles used in the Ågesta reactor.

3.3.1.2. Germany and Argentina

The principal features of the reactors designed and constructed by Siemens-KWU are as follows:

- The reactor core is approximately cylindrical and consists of vertical fuel assemblies located in the same number of fuel channels. The coolant channels are arranged on a triangular lattice pitch of 272 mm and penetrate the top and bottom ends of a circular tank (moderator tank) containing moderator water within the pressure vessel.
- The reactor heavy water coolant and the moderator heavy water are kept at nearly the same pressure through holes in the moderator tank communicating with the upper plenum. This allows the use of thin walled fuel channel tubes to separate both fluids. The fuel channel tubes can be categorized as reactor internals. Also, the two systems use the same auxiliary systems to maintain water quality.
- The heavy water from the coolant circuit is fed from inlet nozzles in the upper part of the vessel to the bottom of the pressure vessel (lower plenum) through the downcomer, as in a PWR. Similarly, but through separate inlet nozzles, the

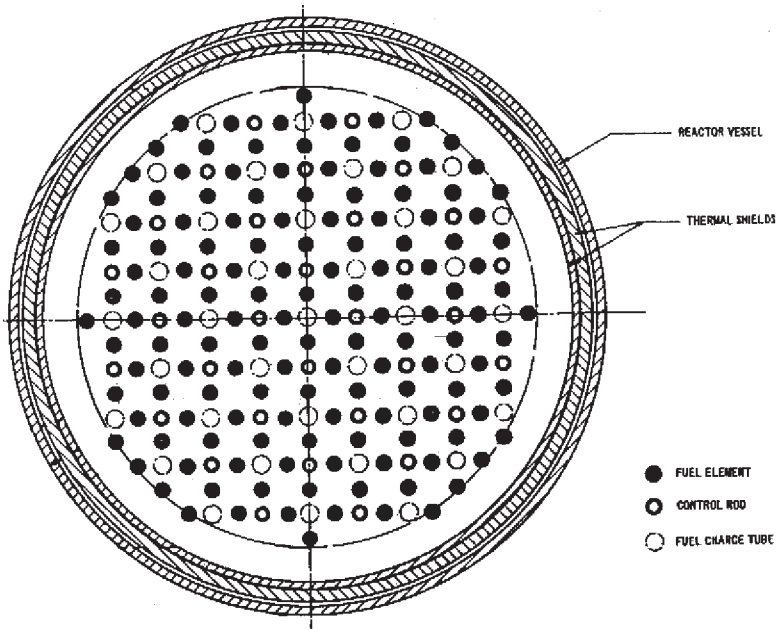

FIG. 42. Arrangement of fuel channels and control rods in the Ågesta reactor.

moderator heavy water is distributed by a header in the bottom of the moderator tank and exits from an upper header near the top of the tank. The primary coolant heavy water is distributed to the fuel channels from the lower plenum at the bottom of the vessel.

- The heat in the moderator water is used to preheat the feedwater, producing a net efficiency of operation of approximately 29% for Atucha 1 and 32% for Atucha 2.
- The reactivity can be controlled by 'black' and 'grey' absorbers arranged in groups or banks of three azimuthally symmetric absorber rods. These penetrate the vertical matrix of fuel channel tubes at an angle to the vertical. The reactivity can also be controlled by boron additions and by varying moderator temperature.
- The reactor can be refuelled on-power with a single fuelling machine operating above the reactor vessel cover head.
- The containment is a spherical stainless steel housing which is protected against external impacts by the surrounding reinforced concrete reactor building.

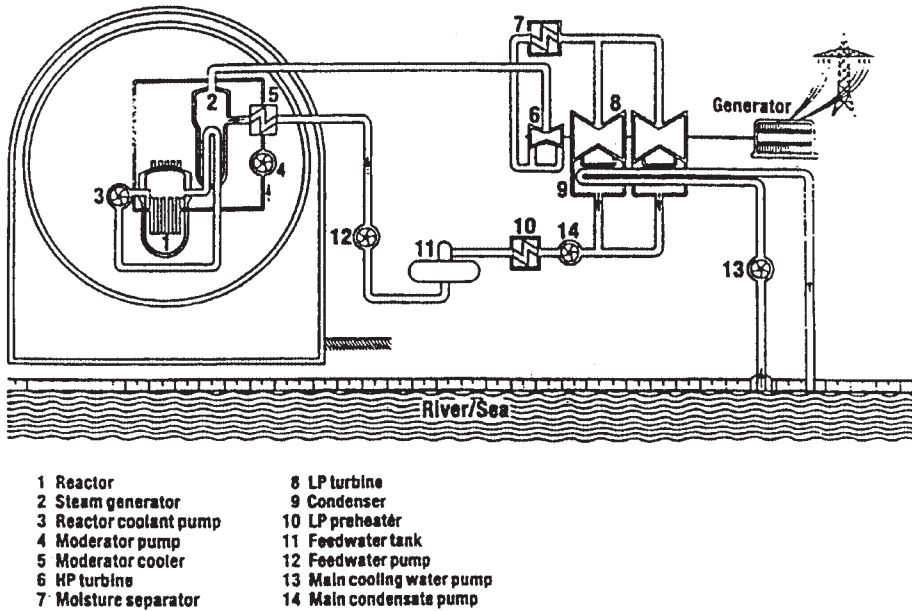

FIG. 43. Simplified flow diagram of a pressure vessel heavy water cooled and moderated reactor.

3.3.2. Heat transport/moderator system

The HTS consists of the reactor vessel, two steam generators, two primary pumps and the pressurizer which keeps pressure at approximately 11.65 MPa.

The system has two loops, and for Atucha 1 the exit temperature from the pressure vessel is $\sim 300^{\circ}\text{C}$ and the inlet temperature of the return coolant into the pressure vessel is 265°C . The moderator outlet flow from the moderator tank has a temperature of approximately 210°C , which is high enough to enable the moderator cooler to be used for feedwater heating. The circuit used for purification and degassing is a side loop off the moderator circuit.

At shutdown, the moderator cooling system is used as a residual heat removal system. In this case, instead of feedwater preheating, the secondary side of the moderator coolers circulates light water from the intermediate reactor heat removal system, which in turn is cooled by water from the Brana river.

A simplified flow diagram is shown in Fig. 43 and the circuit parameters for Atucha 1 are illustrated in Fig. 44 [36, 37].

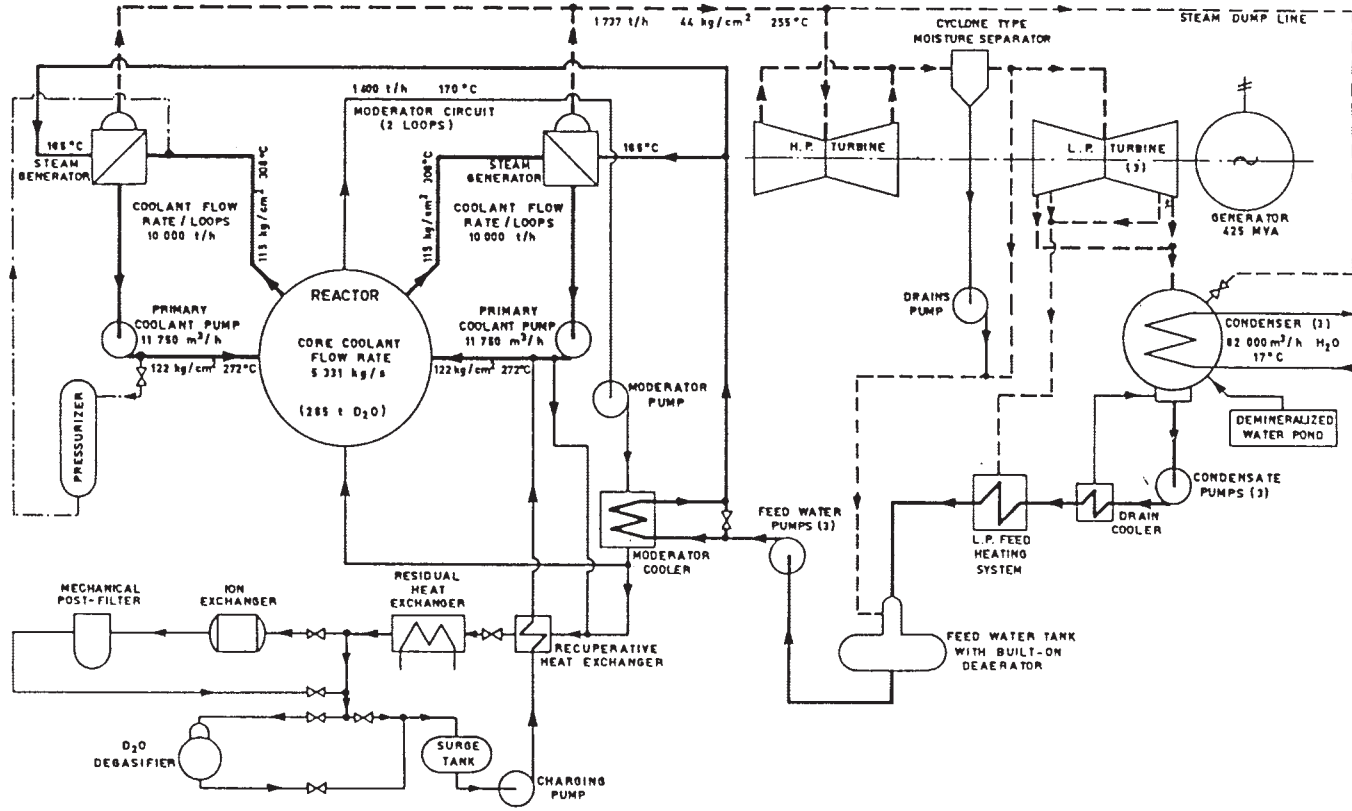

FIG. 44. Circuit parameters for Atucha 1 pressure vessel HWR.

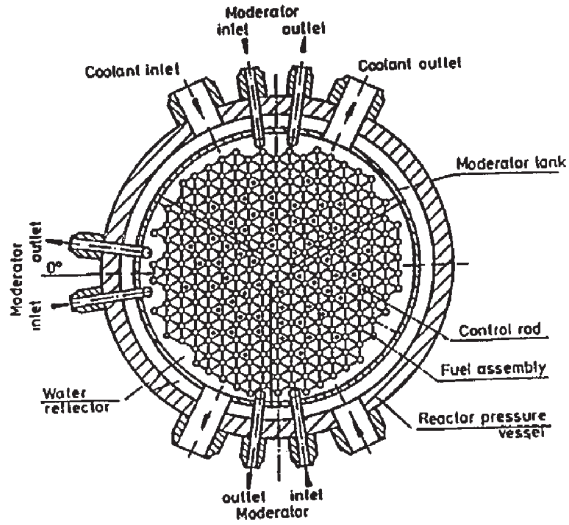

FIG. 45(a). Horizontal section of an Atucha type pressure vessel HWR.

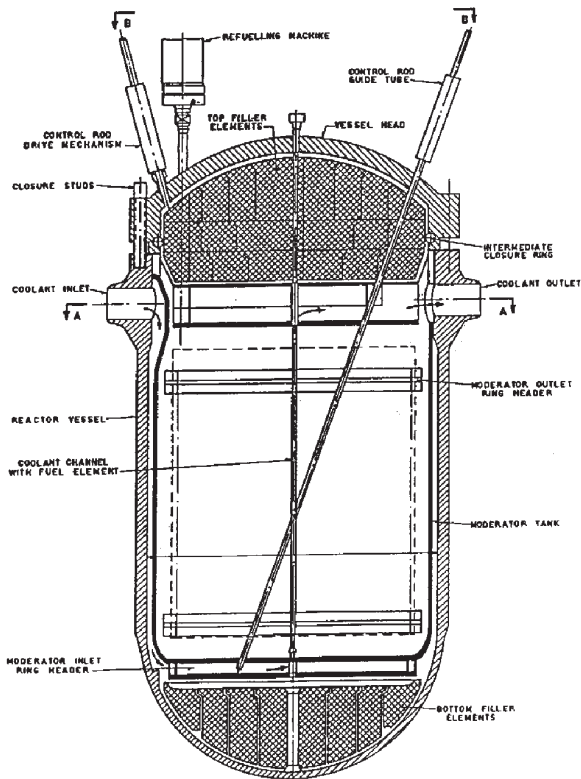

FIG. 45(b). Vertical section of an Atucha type pressure vessel HWR.

3.3.3. Reactor

The components of the reactor vessel are illustrated in Fig. 45. There are no penetrations into the vessel in the core region, i.e. below the top of the moderator tank. Large steel filler elements are located at the top and bottom of the vessel in order to reduce the volume of heavy water. Fuel channel tube extensions with guide tubes penetrate the upper filler elements, allowing access by the fuelling machine. The upper and lower filler elements have water passages to enable the heavy water coolant to maintain the temperature of this region. Most of the coolant flow goes into the fuel channels via the lower plenum. The heated water exits the fuel channel into the upper plenum and is directed to exit nozzles for discharge from the pressure vessel.

3.3.4. Fuel channel tubes

The Zircaloy 2 fuel channel tubes run from below the lower moderator ring header, where they are roll expanded into a stainless steel channel extension containing a lower bearing, down to holes in the moderator tank lower head (which communicate with the coolant lower plenum), and up above the moderator upper distribution header where they are roll expanded into stainless extension tubes that penetrate the moderator tank upper head and the upper filler elements.

Primary coolant heavy water exits from slots in the tubes in the upper plenum. Extension tubes lead from the fuel channel tubes to the top of the pressure vessel head where there are closure plugs that can be opened by the fuelling machine. The fuel is a 37 element bundle with elements supported by intermediate Zircaloy baffle plates [37]. The bundle is spring loaded against the inner side of the fuel channel tubes to prevent fretting and has spring compensating discs at the top and bottom of the active length to accommodate fuel element extension. The fuel design used is shown in Fig. 46.

3.3.5. Fuel handling system

The fuel is removed by a single fuelling machine positioned above the reactor vessel. During the time that the channel is open, a seal is achieved between a sealing ring and the fuelling machine through the weight of the fuelling machine acting against the ring. The fuel string is removed and loaded into the machine and transported to the fuel handling pool where it is positioned horizontally for transfer to the spent fuel bay outside the reactor building. At an intermediate position, the fuel is cleansed of heavy water before entering the light water of the spent fuel bay (Fig. 47) [2].

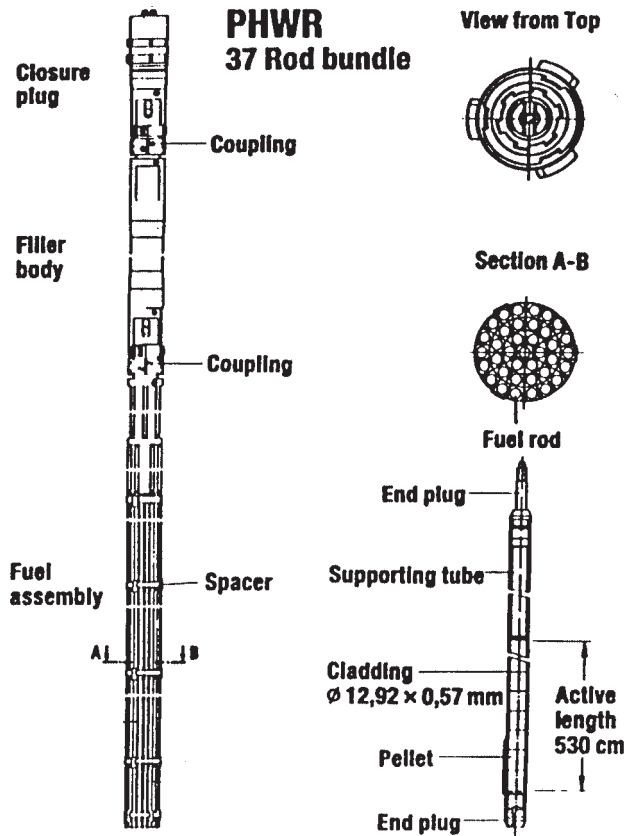

FIG. 46. Fuel assembly for pressure vessel HWR.

3.3.6. Feedwater and steam generating system

Steam leaves the steam generators at a temperature of approximately 255°C and at a pressure of 44 kg/cm² for feeding a single turbine generator. Its passage through the high pressure turbine and into the low pressure turbine via moisture separators follows a conventional arrangement, the only significant difference being the substitution of the moderator cooler for the high pressure feedwater heater.

3.3.7. Reactivity control

The reactivity, and thus the power output of the reactor, is controlled by various methods. At Atucha 1, the reactor contains one black absorber bank made of hafnium

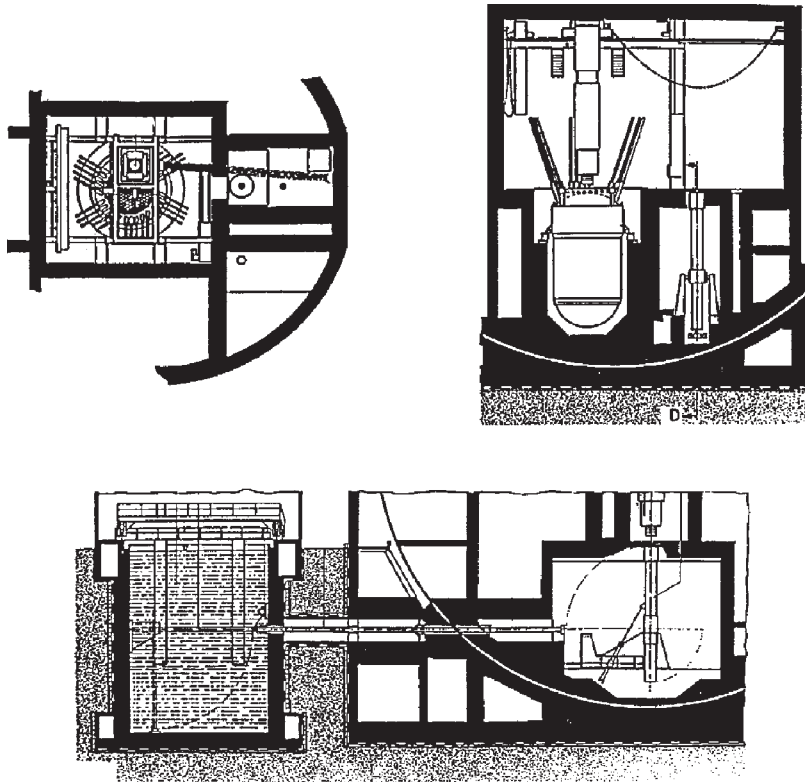

FIG. 47. The fuel transfer process from fuel channel to fuel bay.

and one grey (stainless steel) control bank, each bank comprising three azimuthally symmetric absorber rods. The inclined control elements are used to control the reactivity and the power distribution, to compensate for the buildup of xenon poisoning following a reactor power reduction, to provide damping of azimuthal xenon oscillations, and to shut the reactor down. For this last function, eight black banks are available (shutdown system 1 (SDS1)). The reactivity depth of all control elements is sufficient to shut the reactor down safely into a subcritical state.

In addition to the control elements, reactivity control is provided by the boric acid dosing system. The addition or extraction of boric acid serves to compensate for slow reactivity changes resulting from the burnup during the first period of operation and, for Atucha 2 only, is undertaken in order to maintain the reactor in a safe subcritical condition at zero power. Extraction of the boric acid is achieved using anion exchange columns.

Additionally, a poison injection system (a second independent shutdown system) is provided which injects boric acid into the moderator (SDS2).

In addition to these reactivity control systems, the reactivity can also be controlled by varying the moderator temperature within a certain range, which is advantageous for some operating modes.

At the very start of operation, the reactor is charged with fresh natural uranium fuel assemblies. The excess reactivity of the first core is compensated for by the control elements and by boron admixed with the heavy water coolant/moderator.

Radial shuffling of the fuel assemblies is used to obtain efficient burnup until the use of control rods becomes necessary. Thereafter, new fuel is required. An equilibrium radial burnup distribution in the core is achieved after two complete fuel loadings.

The refuelling rate using natural uranium is of the order of 1.3 or 1.45 fuel assemblies per full power day, respectively, for Atucha 1 and Atucha 2 (exit burnup of 6.0 and 7.5 MW·d/kg U, respectively). The refuelling rate is reduced to 0.7 fuel assemblies per full power day for Atucha 1 using SEU fuel at 0.85% enrichment, and the burnup is increased to 11 MW·d/kg U.

3.3.8. Plant control and operating modes

The control concept of the PHWR is based on an operating mode having a constant main steam pressure bar at the steam generator outlet over the whole load range. As a result, the reactor coolant temperature will rise as the load increases.

This simple mode of operation is made possible by the fact that the coolant temperature coefficient, though comparatively small, is positive, and even a small increase in reactivity is sufficient to cause a power increase. The reactor coolant volume changes are due to temperature variations during load changes and are accommodated for by the pressurizer by varying the set point value for the pressurizer water level in accordance with the reactor power.

The reactor power level is controlled through variation of the neutron flux. For this purpose, the set point power value is pre-set to the neutron flux controller, where it is compared with the actual reactor power value. When the two values are not in agreement, the neutron flux controller withdraws or inserts the control elements into the reactor core and thus changes the reactor power. The main steam generated by the steam generators flows to the turbine, the steam pressure being kept at a constant level by actuation of the main steam valves.

During load rejections, the reactor power is reduced to a predetermined minimum power level, while the excess steam is dumped directly into the condenser via the main steam bypass station. In this case, the main steam pressure is kept at approximately the same value by this station. The condenser is designed to accept 70–80% of the main steam flow, for Atucha 1 and 2.

3.3.9. Safety systems

The safety systems consist of the reactor protection system and the engineered safety systems. The reactor protection system consists of three parts: analogue, logic and control.

The engineered safety systems are:

- Shutdown (black) absorber rods;
- Boron injection system;
- Moderator system;
- Residual heat removal system;
- Various cooling systems, containment isolation and the emergency power supply systems.

3.3.10. Specific reactor features

3.3.10.1. *The MZFR reactor*

Construction by Siemens AG of the initial pressure vessel heavy water reactor, the multipurpose research reactor MZFR, started in 1962. It commenced operation at the Karlsruhe Nuclear Research Centre in 1966. Its electrical output was 57 MW(e). The reactor operated until 1984 with some of its output used for district heating of the Karlsruhe Centre.

A section through the MZFR reactor building is shown in Fig. 48. The reactor vessel was mounted in a massive concrete holder which surrounded the lower part of the vessel. The reactor vessel, shown in Fig. 49, had the basic features seen in the subsequent Atucha 1 reactor. Filler elements occupied the top and bottom of the vessel in order to reduce heavy water volume and the moderator water entered the vessel through a nozzle in the upper part of the reactor and was directed through a downcomer to the moderator distribution header at the bottom of the calandria tank [10]. The primary coolant entered through side ports and was directed to the bottom of the vessel where it was distributed to the fuel channels that passed through the bottom of the calandria tank. The coolant exited from the fuel channels via a domed upper plenum which directed it to two outlet nozzles.

The flow circuit for the nuclear steam supply is similar to that described in Sections 3.3.2 and 3.3.6, the feedwater being reheated by two moderator coolers.

3.3.10.2. *The Atucha 1 reactor*

On the basis of the MZFR performance, the first commercial order for a 330 MW(e) PHWR was obtained by Siemens from CNEA in 1968. The new plant,

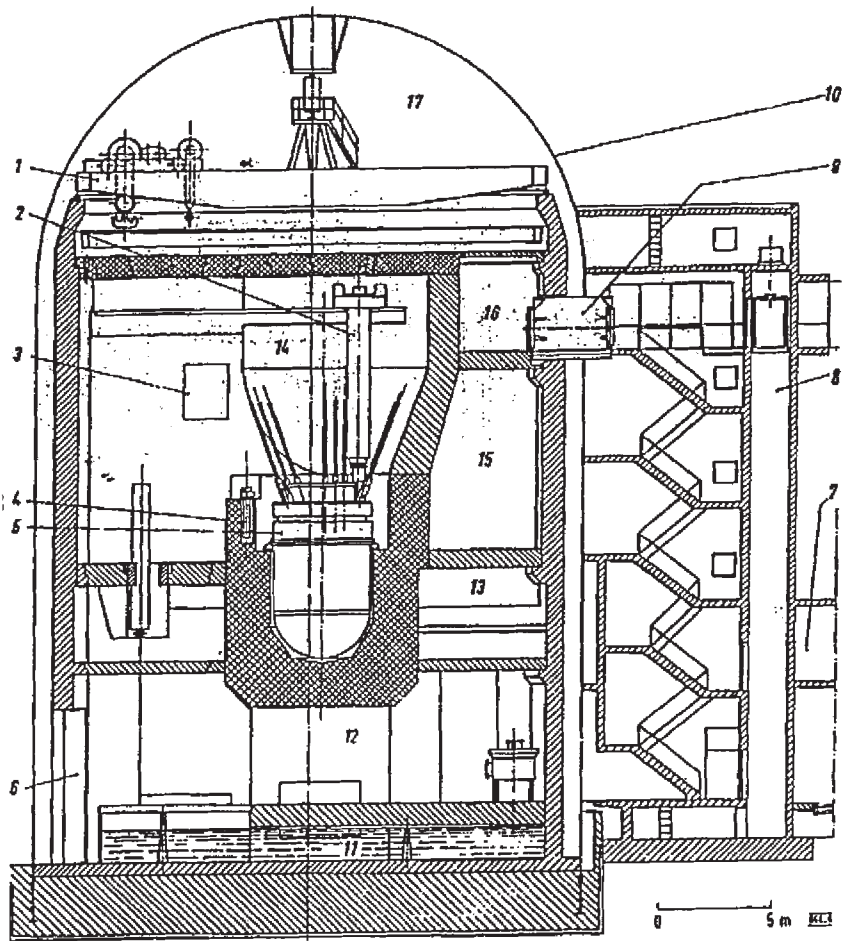

- | | | |
|------------------------------|---------------------|----------------------------|
| 1. Circular Crane | 7. Passage | 12. Basement Assembly Room |
| 2. Fuelling Machine | 8. Hoisting Well | 13. Ring Gallery |
| 3. Overpressure Relief Panel | 9. Airlock | 14. Experiments Room |
| 4. Reset Machine | 10. Steel Vessel | 15. Reactor Vault |
| 5. Reactor | 11. Condensing Pool | 16. Airlock Room |
| 6. Construction Port | 17. Ceiling Room | |

FIG. 48. Cross-section of the MZFR containment.

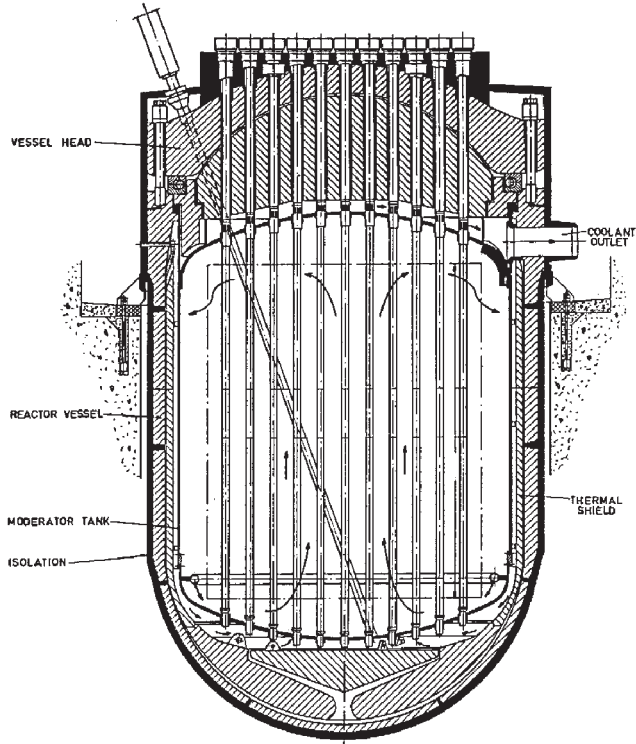

VERTICAL SECTION REACTOR MZFR

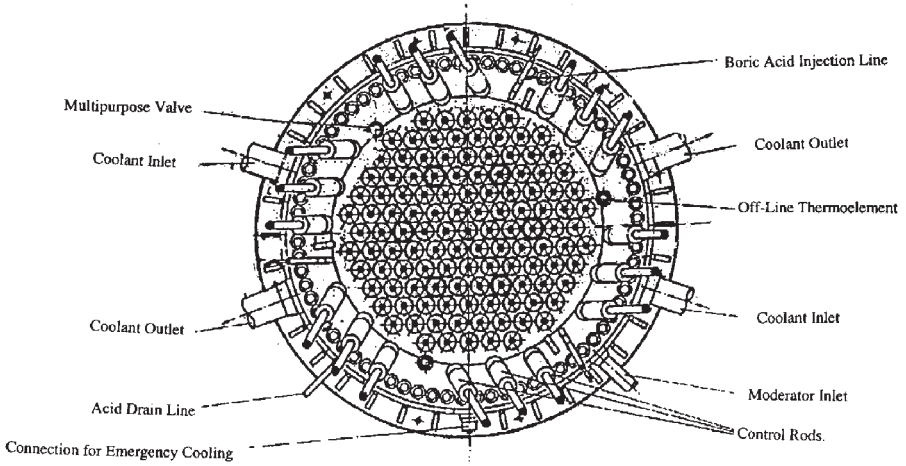

FIG. 49. MZFR pressure vessel, fuel channel and reactivity mechanism arrangement.

Atucha 1, entered into commercial service in 1974 and has operated quite satisfactorily since, reporting a capacity factor near to 90% for most years, except for a major shutdown in 1989–1990 for reactor internal repairs.

The essential parameters of the Atucha 1 plant are shown in the Appendix. Cross-sections of the reactor are shown in Fig. 45. The fuel channel tubes are vertical and are made of Zircaloy 2. These were initially surrounded by two, thin, tubular isolating elements, also of Zircaloy 2 and designed to limit the thermal gradient through the fuel channel tube wall by creating stagnant layers of moderator around the fuel channel tube. Owing to the severe hydriding of the thin (0.1 mm) intermediate Zircaloy insulating tube, the design has been modified in replaced channels to a single isolating tube.

The primary heavy water coolant is received from the inlet nozzle and directed through the downcomer to the bottom of the vessel, proceeding up from the lower plenum into the fuel channels. The pressure differential between the moderator and the primary coolant water inside fuel channel tubes is only small and therefore the fuel channel tubes can be kept relatively thin (1.7 mm) [11].

There are 252 vertical fuel channel assemblies in the core with 29 shutdown and control rods penetrating into the moderator at an angle of about 20°, as shown in Fig. 45 (b).

The reactor has two coolant loops with a steam generator servicing each loop. The moderator water is used to heat the feedwater and the reactivity can be controlled to some extent by varying the temperature of the moderator water. Boron can be added as a poison on startup to offset excess reactivity.

The reactor is fuelled on-power by a fuelling machine that sits above the reactor and which uses its own weight to seal the fuel channel extension during fuelling. The fuel is natural uranium (SEU (0.85% ²³⁵U) is now being substituted for natural uranium in order to reduce fuel costs) arranged in a 37 element bundle, each element clad with 11.9 mm diameter Zircaloy 4 tubing, 0.5 mm thick. The fuel rods are threaded through and supported by intermediate Zircaloy baffle plates. Typically, a burnup of 11.4 MW·d/kg U is now achieved with 0.85% enriched uranium. The active fuel rod length is 5300 mm.

The fuel assembly is transferred by the fuelling machine from a channel to a position for flasking [11]. The fuel string is then tilted to the horizontal position for transfer along the fuelling canal, where it is dried of heavy water before placing it vertically in the spent fuel pool (Fig. 47).

The inlet and outlet temperatures of the heat transport heavy water are 265°C and 300°C respectively.

The thermal reactor power is 1179 MW, generator output is 357 MW(e) and net plant power totals 335 MW(e). The average moderator temperature varies between 170°C and 210°C.

The containment for the Atucha 1 reactor system is spherical and further protected by a reinforced concrete domed cylindrical shell. The plant layout and other plant features are similar to the Siemens-KWU PWRs.

The ECCS has a higher pressure stage made up of accumulators and light water tanks, and a lower pressure stage with pumps; quite similar to the ECCS of PWRs.

The reactor has operated well, with an overall load factor of 71%. The reactor has required replacement of the channels because of excessive hydriding of the isolation tubes around the fuel channel tubes. Replacement of the channels has been undertaken during annual outages and was completed in 2000.

3.3.10.3. *The Atucha 2 reactor*

The Atucha 2 reactor, currently under construction adjacent to Atucha 1, is a 745 MW(e) unit developed from the Atucha 1 design by Siemens-KWU [12]. Many of the components have a conceptual design identical to those of Atucha 1, while the plant layout and other features are derived from the design of the pre-Konvoi and Konvoi 1300 plants. Construction of the reactor started in 1979. This plant has not been finished because of lack of funding and it remains about 80% complete.

The reactor has 451 coolant channels arranged on a triangular lattice pitch of 272 mm with an intended inlet temperature of 277°C, an outlet temperature of 314°C and a pressure of approximately 11.65 MPa. The reactor core is approximately cylindrical in shape and contains a moderator tank with the described inlet and outlet distribution headers for the moderator water. The reactor coolant flows inside the fuel channel tubes and leaves the channel through slots at the upper plenum formed by the top plate of the moderator bank and the bottom of the upper filler pieces. As with Atucha 1, coolant flow restrictors at the channel inlets adjust the coolant flow to the radial neutron flux distribution.

The reactor coolant system and the moderator system are maintained at equal pressure by pressure equalization openings of the moderator tank closure head. As with Atucha 1, the connection between the two systems allows the use of common auxiliary systems to maintain water quality.

The HTS consists of two loops, each consisting of a steam generator, coolant pump and piping. A pressurizer system is connected to one loop and comprises the pressurizer vessel, electric heaters in the vessel, a surge line, spray lines with valves and safety valves. The pressurizer maintains the appropriate pressure to prevent boiling under all operating conditions, and to absorb volume fluctuations in the system during load changes. The safety valves in the pressurizer system open to protect against overpressurization of the system and the released steam is discharged and condensed in the pressurizer relief system.

The moderator system has four loops comprising a moderator cooler, moderator pump, and interconnecting piping and valves. The moderator system can function in three modes. In normal operation, the system maintains the moderator at an outlet temperature of ~200°C and an inlet temperature of 140°C. The heat transferred in the moderator cooler preheats the feedwater. In a residual heat removal mode, the system

is switched around so that heat is extracted from the bottom of the moderator tank and fed into the cold legs of the reactor coolant loops and also into the reactor coolant inlet annulus of the reactor vessel. In an emergency core cooling mode, the moderator serves as a high pressure core reflooding and cooling system. It is similar in action to the residual heat removal mode but in addition water is injected into the hot legs of the reactor pressure vessel.

One property of the moderator system is that it allows the hot shutdown condition of the reactor to be maintained for as long as required or to cool down at a pre-set rate and achieve emergency core cooling without main steam blow off.

The fuel assembly is very similar to that of Atucha 1. It consists of 37 elements arranged in three concentric rings, a rod supporting plate and Zircaloy baffle plates to line up the fuel elements, and the linkage with a coupling for connection to the upper filler body.

The steam generators in the primary circuit are conventional Siemens-KWU U-tube design with alloy 800 tubing.

The ECCS is conceptually similar to that of Atucha 1 and to that of the Siemens' PWRs. The same applies for the electric supply system and other plant features, which are quite similar to those of Konvoi plants.

3.3.10.4. The Marviken reactor

In Sweden, in 1960, a direct cycle pressure vessel boiling heavy water reactor was planned as a promising parallel concept to the Ågesta pressurized water reactor [13]. The reactor system was intended to produce, initially, saturated vapour (at 4.7 MPa and 260°C) to drive the turbine and produce a power output of 140 MW(e), and eventually, with the fuelling of superheat channels, the production of superheated vapour (at 4.1 MPa and 475°C) to achieve a higher power output (200 MW(e)).

In 1963, a decision was made to construct a 140/200 MW(e) prototype as a direct cycle reactor turbine layout for a boiling heavy water reactor core. The construction schedule called for the reactor to go critical in 1968. The reactor site, at Marviken, was located on a peninsula 120 km southwest of Stockholm.

The major aim was to verify the performance of natural uranium fuel in saturation boiling, for large reactors, although slightly enriched fuel (1.35% ^{235}U and 1.75% ^{235}U (superheat channels)) was planned for use in the initial cycles in order to reduce the prototype size and make superheat possible [38]. ASEA was the reactor equipment designer and supervised manufacture, assembly and commissioning work. The 23 m high reactor vessel was constructed and shipped to the site and installed in 1967.

In the reactor design, the feedwater from the condenser (at 110°C) is led into the bottom of the reactor via 21 feedwater inlet nozzles (Fig. 50). The water circulates in the moderator tank and rises to the top, after which it flows radially above the top reflector into a zonal space where it mixes with heated water from the boiler channels

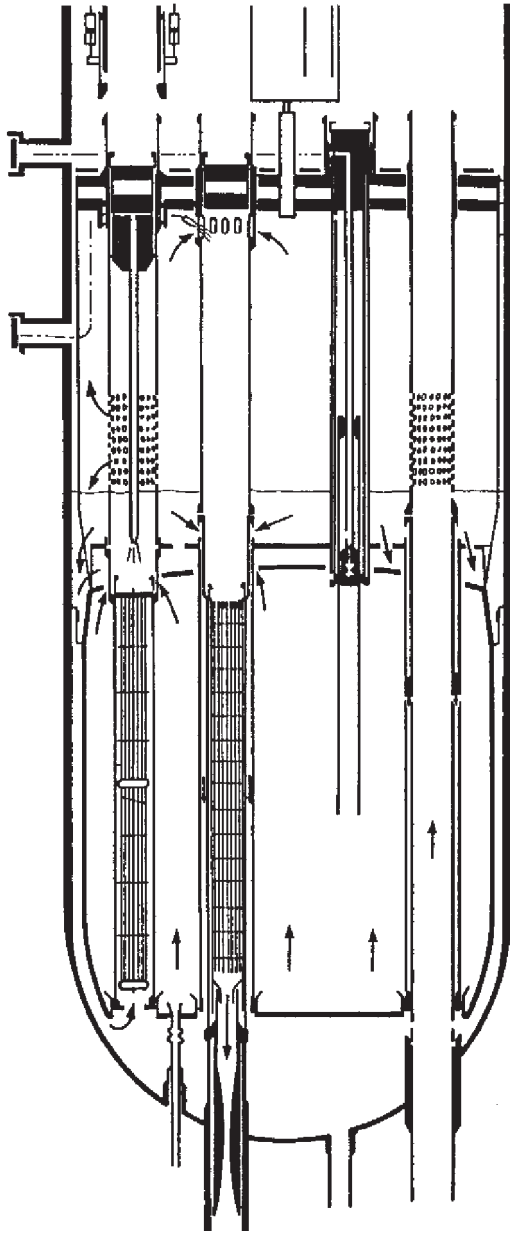

FIG. 50. Flow paths through the channels of the Marviken pressure vessel.

before entering an annular downcomer between the vessel wall and the moderator tank wall. This water flows through the downcomer to the inlet plenum located below the moderator tank. Slightly subcooled, the heavy water enters the 147 boiler channels in which the water rises under boiling conditions. The steam–water mixture leaves the channels through an outlet above the normal water surface. The steam from the boiler channels rises in the steam dome and separated steam enters the 32 superheater channels at a higher level and makes a downward passage through the core to the outlet nozzles which are connected to an external outlet header. From the header, the steam flows to the turbine. Valves control the flow in each superheater channel when fuelled, but are open for saturated flow.

The reactor was intended to have refuelling equipment internal to the pressure vessel and above the core for fuel shuffling and refuelling on load. The fuel was to be lifted by a grab from the core channel and spray cooled while being transferred into a manipulator tube (Fig. 51). The fuel was then to be lowered into a fuel chute tube which penetrated the bottom reactor shell, and into a transfer lock for drying before discharge into a light water fuel storage pit. The drive cables for the fuel transfer mechanism were to be actuated from outside the reactor through the uppermost dome. Reactivity control was to be achieved with 16 regulating rods and 24 safety rods arranged as shown in Fig. 52. The absorbers (70% silver, 30% cadmium) were tubular and canned in stainless steel, except for a small number of purely stainless steel absorber tubes used for fine control. The actuating mechanism was to be operated hydraulically using D_2O , and the actuating system located outside the reactor.

The boiler channel fuel assembly was a 36 element structure arranged in three concentric rings. It consisted of a lifting head, a central support tube, two bumpers and seven spacers. The bumpers protected the assembly during charging operations. The total length was 4.75 m and the active length 4.42 m. The weight of fuel in each assembly totalled 200 kg. The fuel, in the form of pellets 12.4 mm in diameter, was enclosed in Zircaloy 2 tubes 0.63 mm thick.

The turbine and feedwater system for Marviken required that special consideration be given for sealing and for simplifying of the feedwater system in order to reduce D_2O volume, as well as recombining D_2 and O_2 . Additional concerns identified were [39]:

- Contamination by activated corrosion products and radioactive inert gases in the steam,
- High oxygen concentrations due to radiolytic decomposition in the steam,
- Presence of chloride salt in the steam as a result of condenser leaks.

These all required the incorporation additional design features in order to reduce their importance.

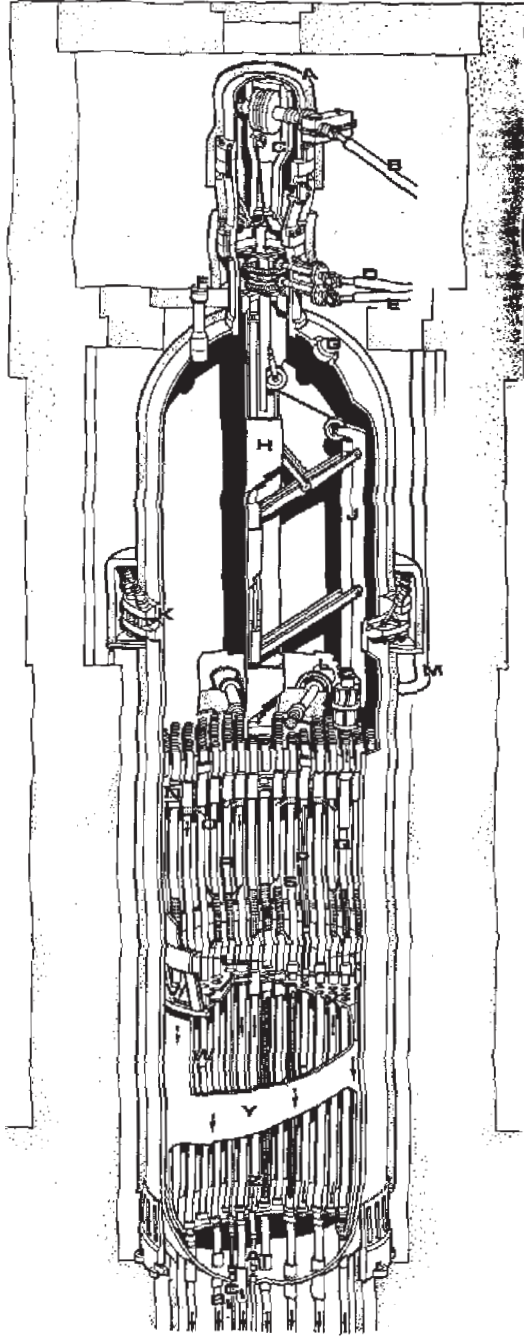

FIG. 51. Pressure vessel of the Marviken reactor showing internals, including fuelling equipment.

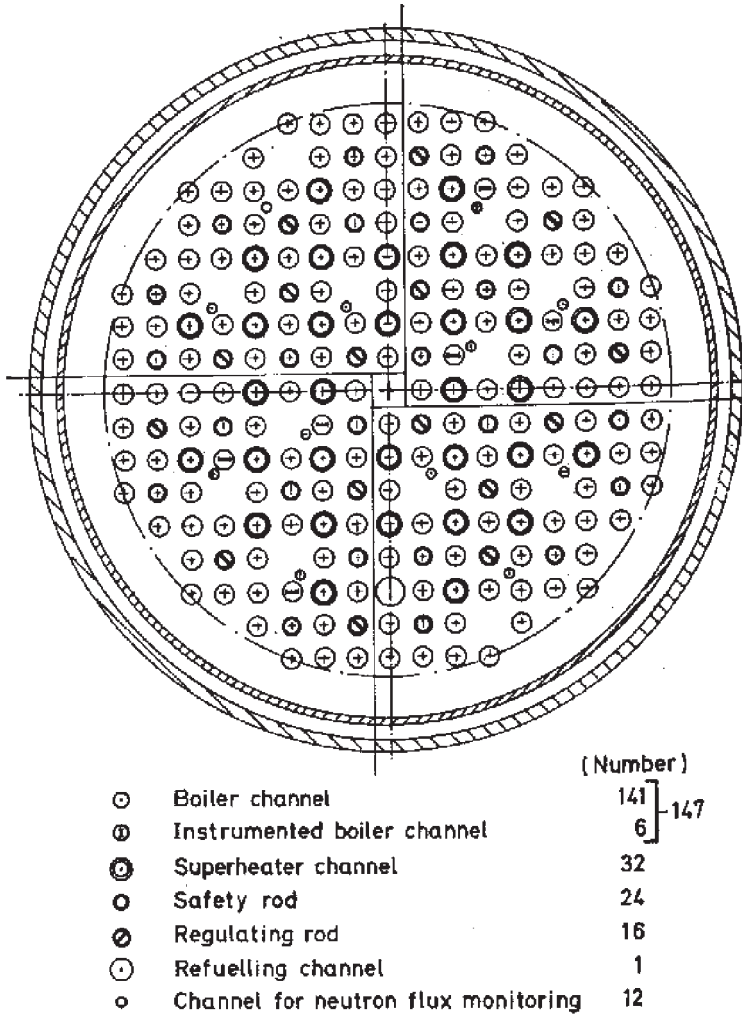

FIG. 52. The core lattice of the Marviken reactor designed with a 250 mm lattice pitch.

However, despite considerable development and light water testing of the reactor system, the decision was taken in April 1970 not to complete the reactor, because of the additional investment and development time (2–3 years) required for completion and because of the loss of interest in this reactor design on the part of the utilities [35].

Unsatisfactory factors which also influenced this decision were as follows:

- Void and fuel temperature coefficients of reactivity, which were predicted to be negative, were, from subsequent information and measurements, found to be less favourable;
- Condensation occurring in the superheated fuel channels under saturated steam conditions during preliminary tests with light water;
- Safety reviews subject to the more rigorous criteria that had become current indicated that several additions to the hardware were necessary.

3.4. CHARACTERISTICS OF HEAVY WATER MODERATED, GAS COOLED REACTORS

3.4.1. Introduction

Four gas cooled pressure tube reactors of relatively small size were built in the 1960s with the object of exploring the use of CO₂ as a heat transport fluid in combination with heavy water moderation instead of graphite. The reactors had innovative fuel designs and most had the pressure tubes vertically oriented although the most successful unit, the EL 4 plant in France, had the pressure tubes horizontal. The potential advantages were low neutron absorption by the coolant and high outlet coolant temperatures available at moderate pressures. The disadvantages lay in the relatively poor heat transfer and heat transport properties of CO₂.

The advantage of using CO₂ is that the heat transport gas can be heated to much higher temperatures than is possible with water and achieve higher thermal efficiencies at the turbine. Typically, the temperature reached by the CO₂ is about 500°C. The heat is exchanged in steam generators to produce the steam to drive turbines. A simplified flow diagram based on the EL 4 system is shown in Fig. 53 [40].

3.4.2. Specific reactor plants

3.4.2.1. *The EL 4 reactor*

(a) General description

The EL 4 reactor (70 MW(e)) was constructed at the Mont d’Aree site near Brennilis, France. The heavy water moderator is contained in a horizontal cylinder 4.6 m long and 4.8 m in diameter. The 216 fuel channels, arranged on a square pitch

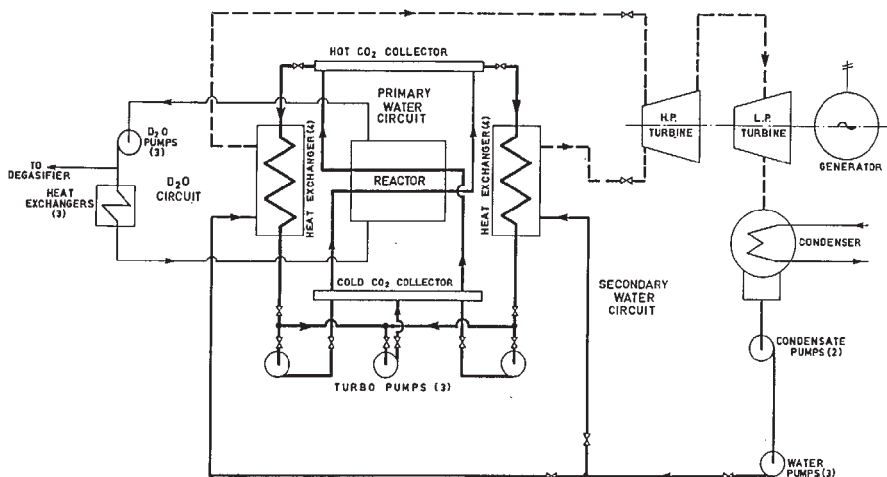

FIG. 53. Simplified flow diagram of the EL 4 nuclear plant.

of 234 mm, are contained in Zircaloy tubes. The Zircaloy pressure tubes (107 mm inside diameter and 3.2 mm wall thickness) are able to operate at a low temperature by virtue of their being thermally isolated from the hot CO_2 gas by a stainless steel guide tube and by thermal insulation installed between the guide tube and the pressure tube [14, 41]. The pressure tube is rolled into the end shields and, as a result of the greater thermal expansion of the steel vessel, is put into axial tension during operation. There are nine fuel bundles in each channel. The CO_2 enters the channels at a temperature of 235°C and exits at a temperature of 475°C and a pressure of 5.5 MPa. The end shields of the reactor contain light water for cooling and radiation shielding. Control rods penetrate the reactor vertically between the fuel channels and are supported above the reactor from a platform (Fig. 54).

The hot CO_2 gas exits the channel and is piped to collectors above the reactor from which it is distributed to each of four column heat exchangers arranged in two circuits. The steam produced is sent to the turbine and the cooled CO_2 returned to the fuel channels. Part of the steam is diverted to turbo-soufflants or steam turbine driven blowers which pump the CO_2 back to the channels.

The channel is fuelled by fuelling machines positioned at each end of the reactor. The fuel is in short bundles containing UO_2 enriched to 1.4% ^{235}U (1.3–1.6%). Short pellets of sintered UO_2 were contained initially in rectangular

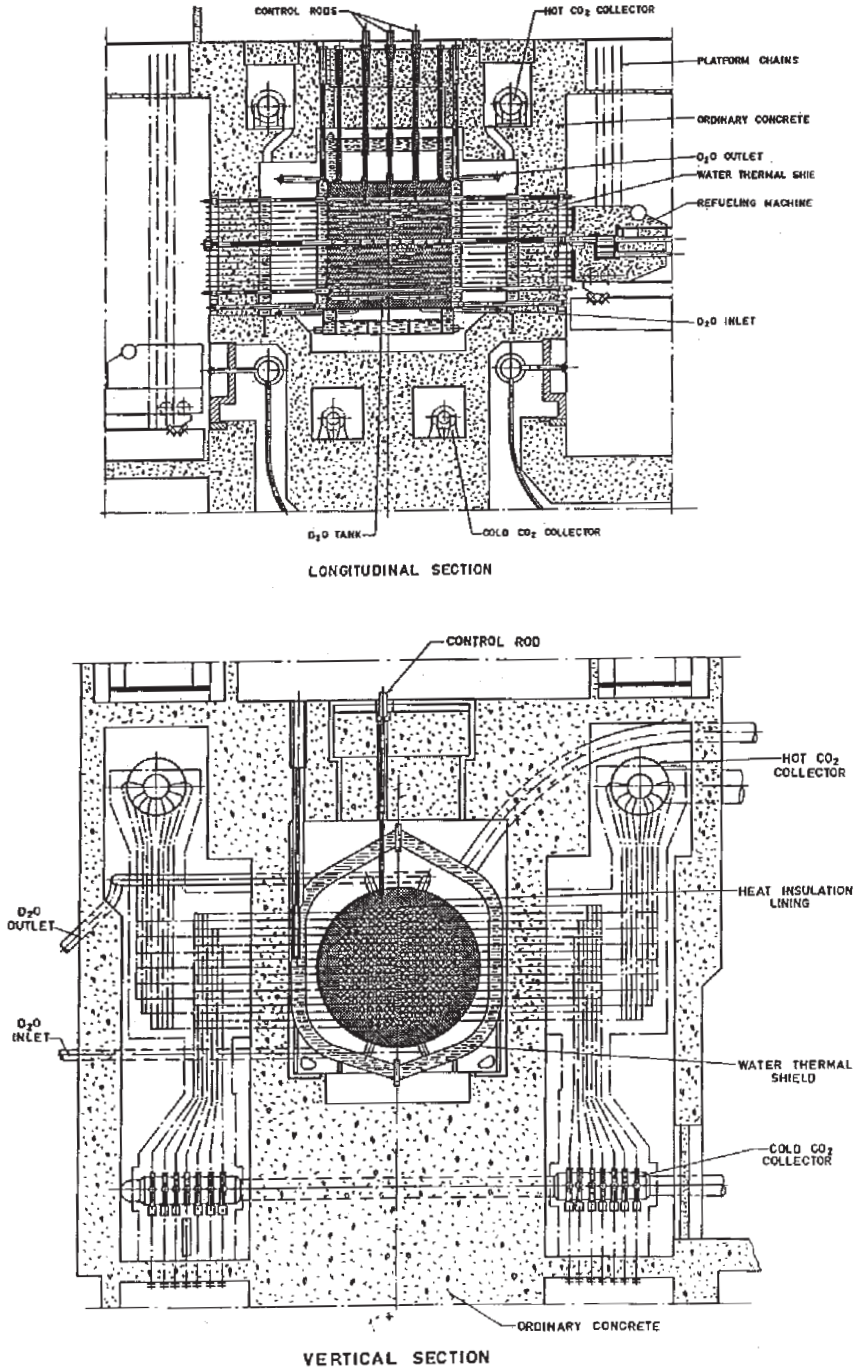

FIG. 54. Longitudinal and vertical sections of the EL 4 reactor.

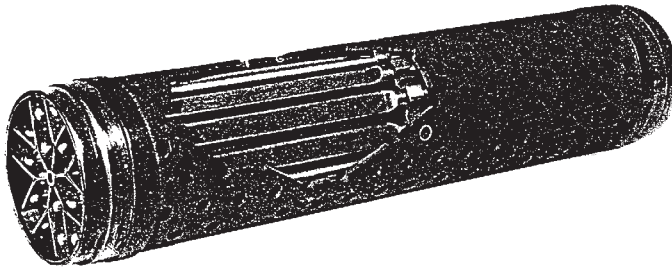
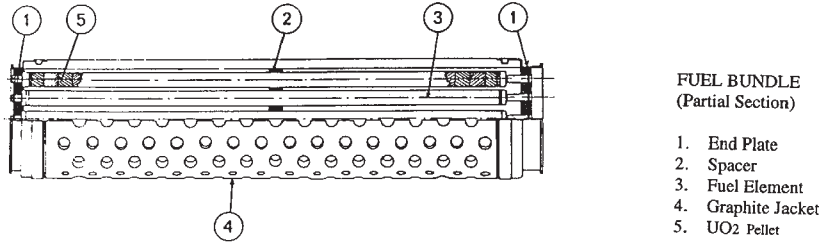

FIG. 55. The fuel bundle design used initially in the EL 4 reactor.

cross-section stainless steel sheaths. As a result of the poor performance of the stainless steel, the fuel cladding was changed to a Zr-1.8%Cu alloy in a corrugated form [42]. There are 19 fuel elements in each bundle. In order to increase stiffness and facilitate handling during assembly, the fuel elements are encased in a perforated graphite tube (Fig. 55). The fuel elements are introduced at the hot end of the channel and removed at the cold end. The fuelling machines were required to change 16 fuel bundles daily.

(b) Reactor

The reactor is enclosed in a domed cylindrical building, 56 m in diameter and 46 m high, with walls 60 cm thick. An illustration of the building and layout of the components and systems is shown in Fig. 56.

(c) Operation

The EL 4 reactor started up in 1965. It had initial problems with steam generators which were overcome in the first two years of operation, and it was not able to use beryllium alloy fuel cladding as intended. However, it operated successfully until 1985 when it was shut down, together with some other gas cooled

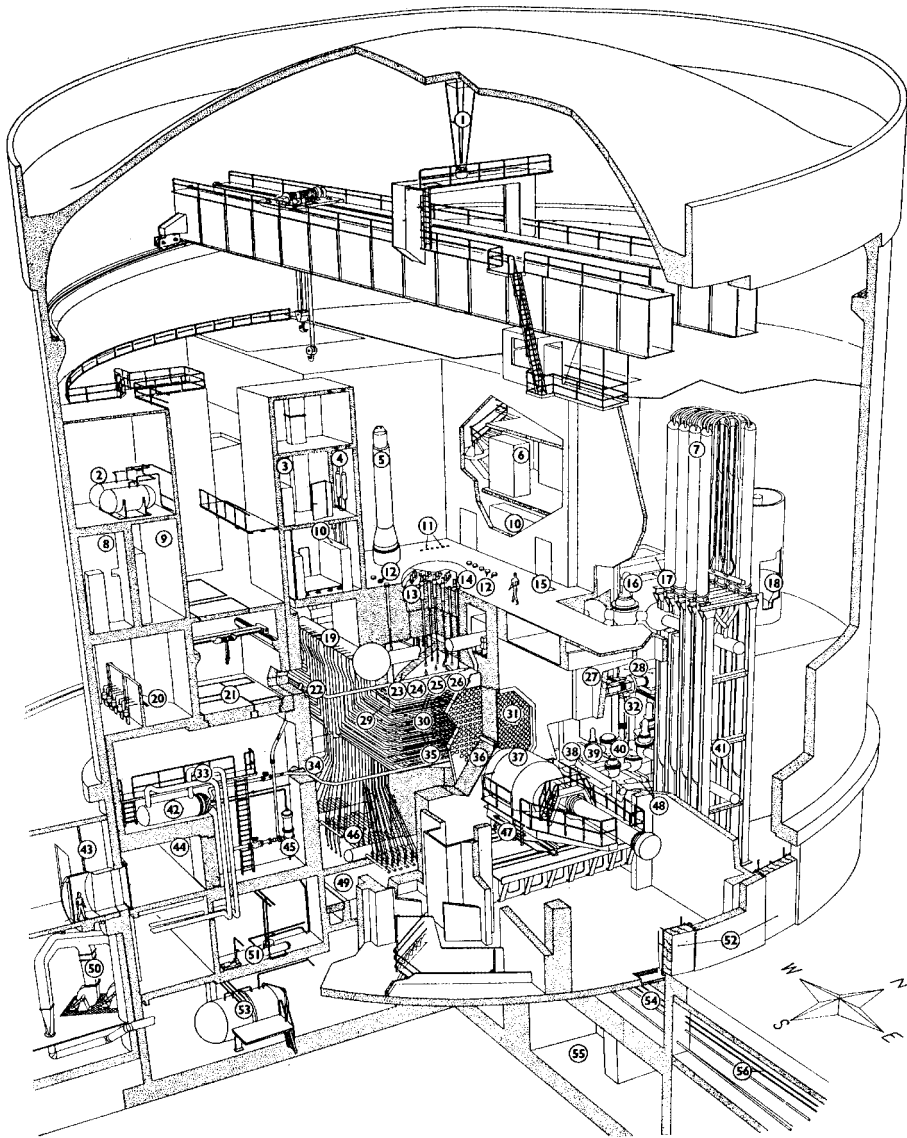

FIG. 56. Illustration of the EL 4 reactor building showing the location of components and systems.

reactors, because Electricité de France (EDF) had decided to concentrate on PWRs. The advantages of this reactor were the relatively low cost per unit of electricity and the low fields occurring in the reactor vault. As a result of the absence of activity transport, the reactor face and vault were accessible when the reactor was on power.

3.4.2.2. *The Niederaichbach reactor*

(a) General

The 100 MW(e) Niederaichbach reactor was designed by Siemens in the early 1960s and constructed between 1965 and 1970 in the Isar valley, about 70 km northwest of Munich [43]. The reactor achieved full power in 1970.

(b) Reactor

The reactor contained 351 vertical channels on a square pitch of 24.5 cm. The channels penetrated a tank or calandria containing heavy water moderator and a helium cover gas. The heat transported by the CO₂ was sent to steam generators in two loops to produce the steam to drive the turbine (Fig. 57) [44].

Vertical and horizontal cross-sections of the Niederaichbach reactor are shown in Fig. 58. Each of the 351 fuel channels contained 4 fuel bundles, each with 19 fuel elements (Fig. 58) [41]. The fuel was clad with stainless steel having a wall thickness of 0.25 mm. Each element was 15 mm outside diameter and 1075 mm long. The UO₂ fuel pellets were enriched to 1.15% [15]. The heat was removed from the fuel with CO₂, which operated at an inlet pressure and temperature of 6.08 MPa and 253°C, and at an outlet pressure and temperature of 5.42 MPa and 550°C.

The fuel channels, which were arranged within a 5.18 m diameter circle, penetrated the cylindrical moderator tank (6.14 m diameter, 7.34 m high). The active core length was 4.3 m. The pressure retaining tube was made of Zircaloy, which was isolated from the hot gas by a foil and thin walled tube and operated at the moderator temperature of less than 100°C. The reactor was designed to be refuelled on power from the top of the reactor, at a refuelling rate of approximately one fuel bundle daily. The channel inlet was at the top of the reactor.

(c) Reactor operation and control

Basic control was achieved by adding a burnable poison, CdSO₄, to the moderator. The moderator level could also be adjusted and the moderator dumped to shut down the reactor.

The Niederaichbach reactor reached full power in 1970 and was connected to the grid in 1973. It was shut down in 1974, when it was deemed to have become

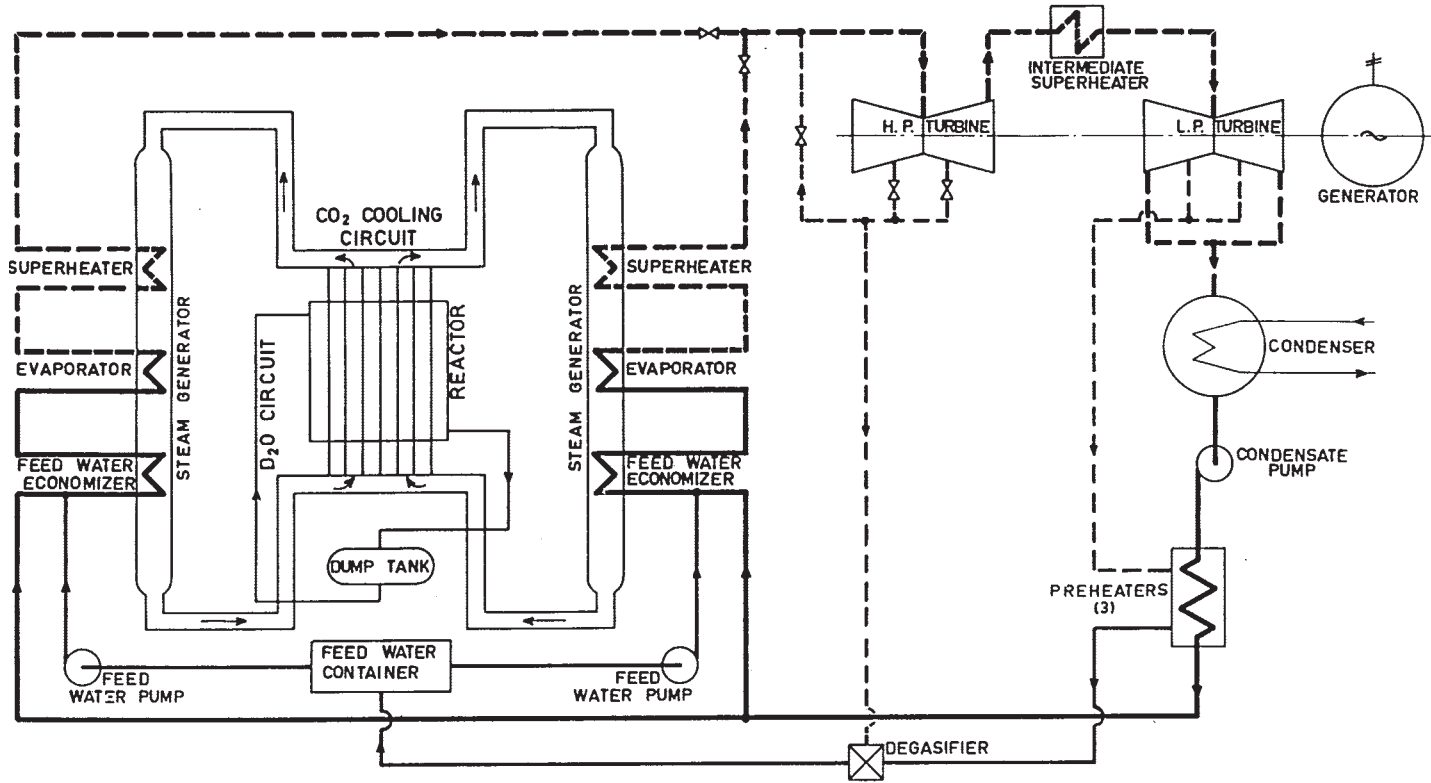

FIG. 57. Simplified flow diagram of the Niederaichbach heavy water moderated, gas cooled reactor.

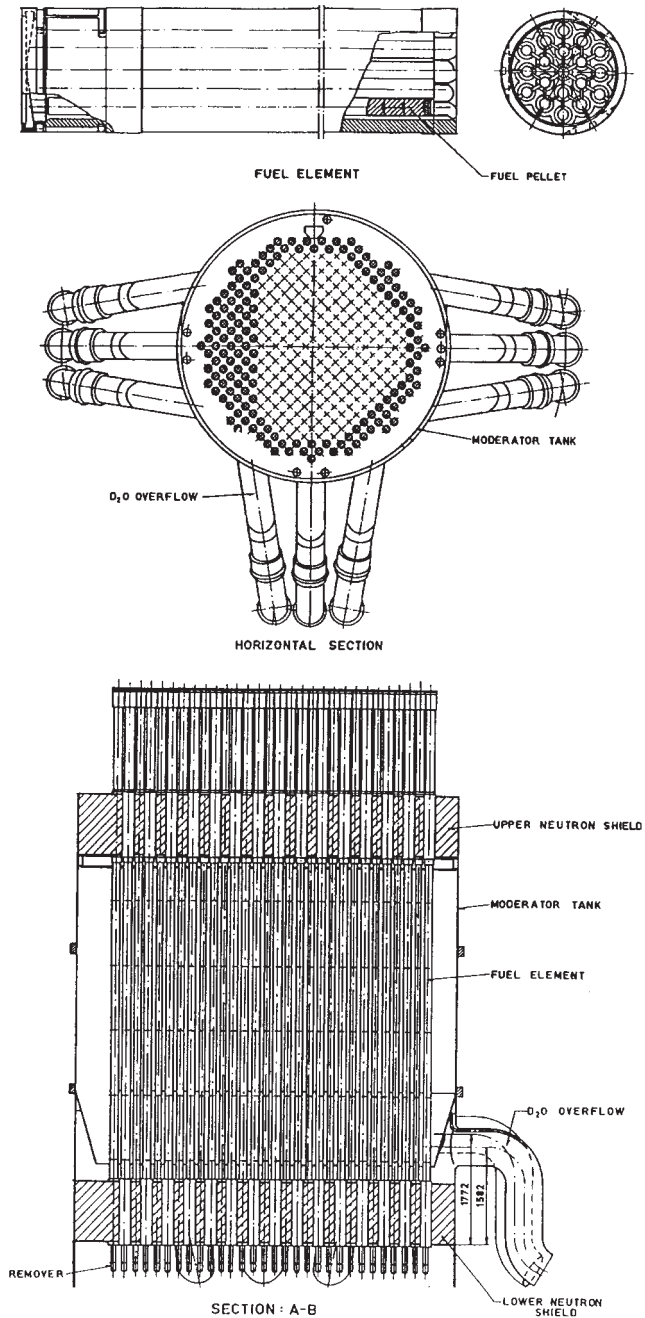

FIG. 58. Horizontal and vertical cross-sections of the Niederaichbach reactor and a longitudinal section through a fuel bundle.

uneconomic compared with other water cooled reactors, and the subsequent decommissioning activity had the objective of demonstrating the ability to return a reactor site to a greenfield condition.

3.4.2.3. *The Lucens reactor*

(a) General

The Lucens reactor was constructed in the period 1962–1968 in underground caverns at a site between Lausanne and Berne [45]. It was a 30 MW(th)/8.3 MW(e) pressure tube reactor with CO₂ cooling and was designed to combine features of the French reactors and the British Magnox units with heavy water moderation [46]. The reactor only operated for a few months when a three month shutdown was required for maintenance. During shutdown, a blockage was caused by the accumulation of corrosion products in some channels resulting from the effects of water condensation on the magnesium alloy fuel cladding. At startup, the flow blockage remained undetected during the subsequent rise to power owing to flow bypass of the blocked subchannels. The cladding melted and further obstructed the flow, leading to a uranium fire, graphite column contact with the pressure tube as a result of bowing and pressure tube failure by overheating and subsequent rupture. The calandria tube was also ruptured. As a result, the reactor was shut down and eventually decommissioned.

(b) Reactor

The reactor consisted of 73 vertical channels which penetrated a 3.13 m diameter moderator tank (Fig. 59). These fuel channels were loaded with fuel element assemblies containing seven fuel rods of metallic uranium encased in a finned Mg–0.6%Zr alloy cladding [24]. The fuel rods were inserted into a graphite matrix (Fig. 60). The channel was of a re-entrant design. The cooler CO₂ gas flowed down an outer annulus between the graphite column and the Zircaloy tube and at the bottom flowed up around the finned magnesium rod, removing the heat. The Zircaloy pressure tube was insulated from the moderator by an aluminium alloy calandria tube and an annular atmosphere of low pressure CO₂. It operated at approximately the inlet gas temperature.

The CO₂ gas entered the top of the channels at a pressure of 6.28 MPa and at a temperature of 223°C. It exited the channel at a pressure of 5.79 MPa and at a temperature of 378°C.

The fuel used was metallic uranium, enriched to 0.96% and alloyed with chromium. The fuel rods were 17 mm in diameter and 650 mm long. The three-piece graphite fuel column was held together by three spring loaded Zircaloy 2 tendon rods positioned on the outside of the graphite.

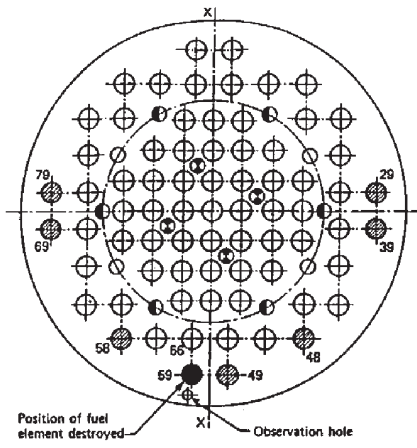

Position of fuel element destroyed
 Observation hole

- Fuel positions where corrosion occurred
- Other fuel positions
- ⊙ Control rod positions
- ⊖ Safety rod positions
- Spare control positions

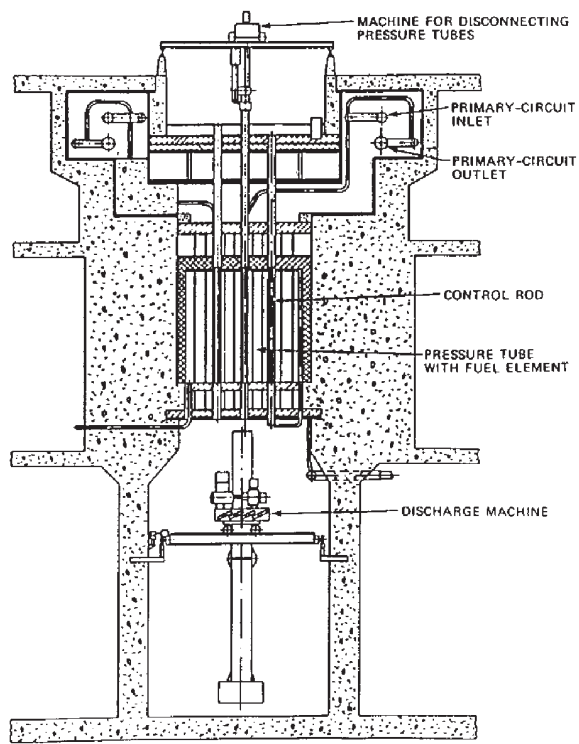

FIG. 59. Horizontal and vertical sections through the Lucens reactor.

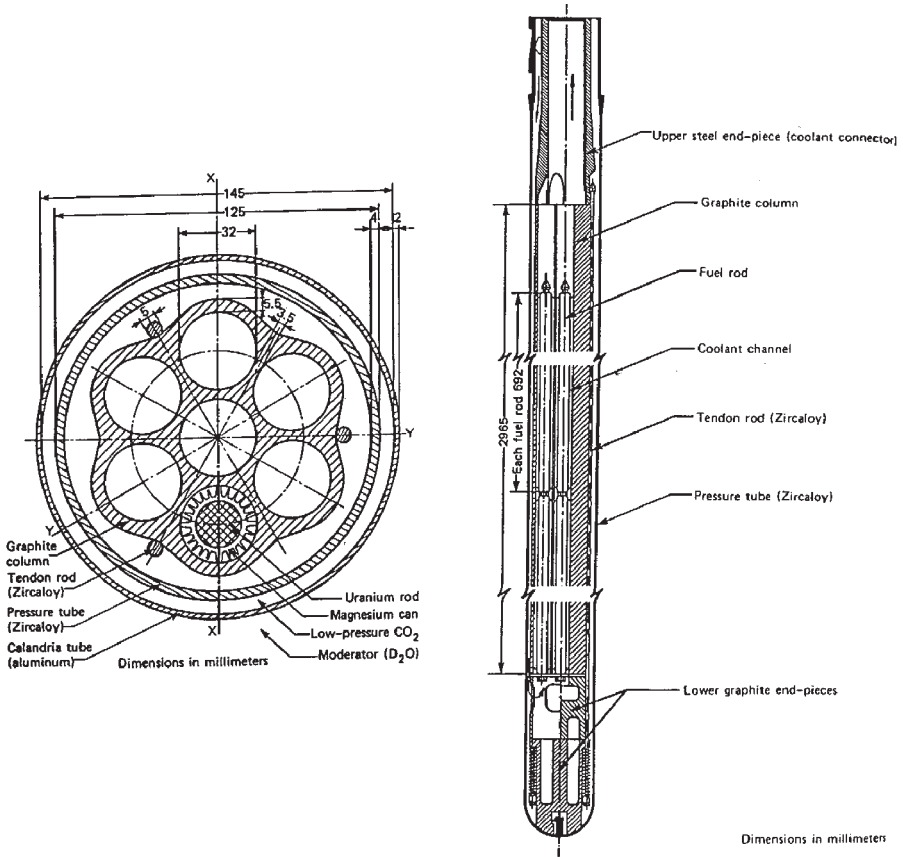

FIG. 60. Horizontal section through the fuel channel and fuel assembly, and a vertical section through the fuel assembly of the Lucens reactor.

The reactor was fuelled using a handling machine located above the reactor and which could remove both channel and fuel together. This machine lowered the spent fuel/pressure tube into a discharge machine located below the reactor.

The core had 14 control rod positions between the fuel channels. Six safety rods were sited on a circle approximately half-way between the centre and the outer diameter of the core, and four others were located close to the centre. Six of the safety rod positions had a reinforced 'calandria' tube surrounding them to protect against potential overpressure conditions as high as 8.1 MPa occurring in the moderator as a result of abnormal events.

The reactor was shielded with steel and concrete in the radial direction and by steel and light water above and below the core.

The reactor was divided into two halves in order to service each of two loops. The interconnected piping circulated the CO₂ gas through the steam generators, which were the first helicoidal ‘once through’ steam generators to be installed in a nuclear plant. They delivered superheated steam to the turbine at a pressure of 2.33 MPa and at a temperature of 370°C.

(c) Operation

The reactor only operated for a few months before the accident described previously occurred. Before commissioning, it was recognized that the design was not supported by the Swiss electrical utilities and its operation was intended for experimental purposes for a limited time in order to perform extensive transient test programmes before its conversion to a test facility for high temperature helium cooled fuel elements.

3.4.2.4. *The Bohunice KS150 reactor*

(a) Introduction

The KS150 reactor was constructed at Bohunice, Slovakia, between 1958 and 1971. It was connected to the grid in 1972 and operated until 1979 when it was shut down. The reactor generated 144 MW(e).

(b) Design

The reactor core was enclosed in a steel pressure vessel (Fig. 61). The moderator heavy water was enclosed in a cylindrical aluminium tank 4 m high and 4.16 m in diameter (in the bottom half of the pressure vessel). The moderator tank was penetrated by 196 vertical channels of which 156 were fuelled and 40 occupied by control rods [41]. The moderator operated at a maximum temperature of 90°C.

The fuel was cooled with CO₂ which entered the vessel near the top into a plenum at a temperature and pressure of 105°C and 6.6 MPa, and after passing down the fuel channels exited via a plenum and from nozzles at a temperature and pressure of 425°C and 5.7 MPa.

In the out-reactor circuit (Fig. 62), the gas was circulated to a series of exchangers, initially, to a high pressure superheater producing steam for the high pressure turbine at a temperature of 400°C and at a pressure of 2.9 MPa. The high pressure superheater was fed from a steam drum heated from a high pressure evaporator and a high pressure economizer following, and in series with the high pressure superheater. The gas was then sent to a low pressure superheater which produced steam for the low pressure turbine supplied from a steam drum heated by a low pressure evaporator and a low pressure condensate heater. The cooled CO₂ was returned to the reactor via six blowers.

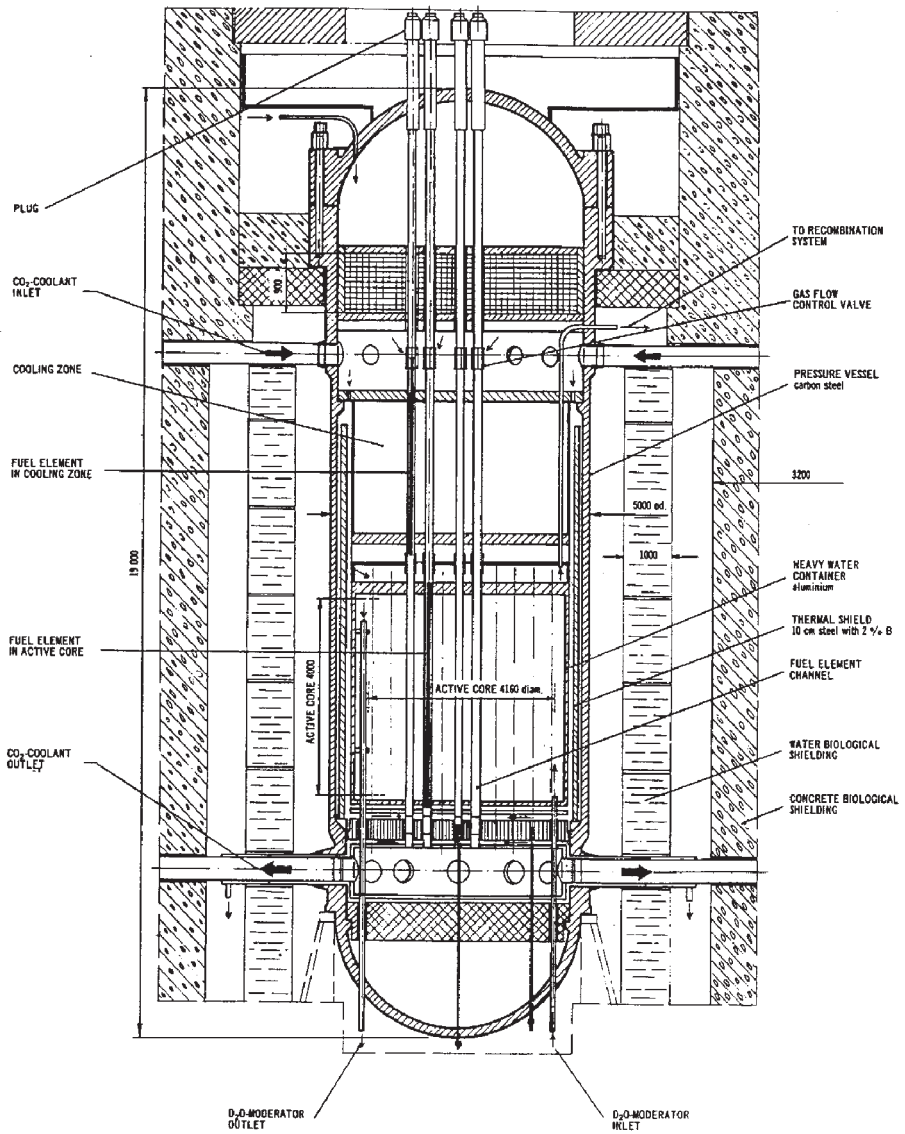

FIG. 61. Vertical section through the KS150 reactor at Bohunice, Slovakia.

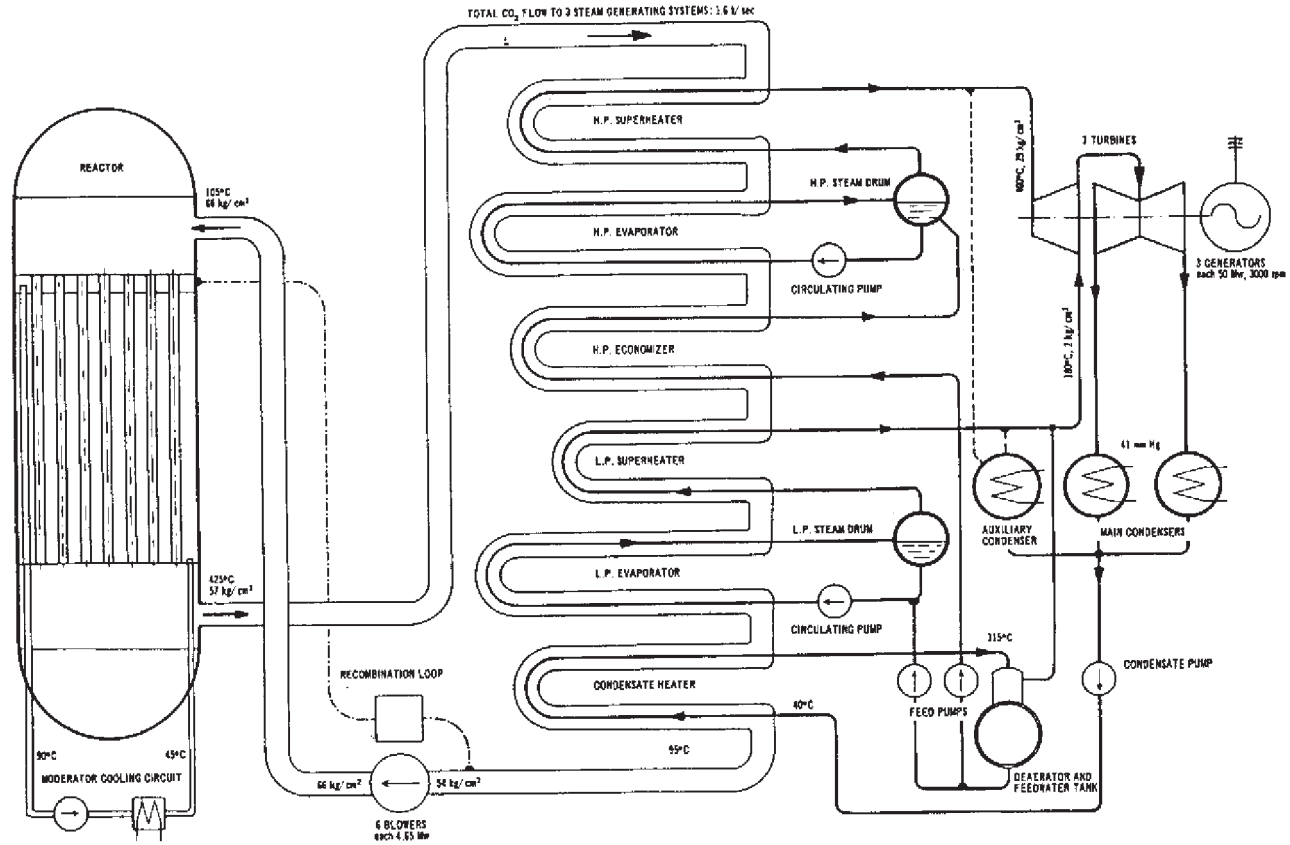

FIG. 62. Flow diagram of the reactor circuits of the KS150 reactor at Bohunice, Slovakia.

(c) Operation

The plant appears to have operated satisfactorily until 1979 when fuel melting occurred. Following that incident the reactor was shut down.

3.5. UNIQUE FEATURES OF HWR TECHNOLOGY

3.5.1. Fuel channel technology

3.5.1.1. Introduction

The components that form part of the fuel channels of various heavy water moderated reactors can be grouped into three main categories:

- *Pressure retaining components*, including the out of core channel extensions and the mechanical closures accessed by fuelling machines in refuelling the channel;
- *Channel support components*, which are more obvious as the end bearings and spacer/calandria tube components in horizontal channels;
- *Channel internals*, which may include radiation shielding plugs, thermal shielding plugs, flow straighteners/modifiers, fuel supports and the fuel.

Since many of the fuel channel designs were 'one-offs', there was little development of most concepts. In the case of the CANDU channel, development has been towards larger diameters and longer channels as the means of achieving higher power outputs at higher temperatures (Fig. 63) [47]. This part of the development has now reached a limit as regards pressurized water conditions and development activities are now being made towards achieving a longer channel life than 30 years, and with limited modification being made to the basic design. A genealogical representation of CANDU fuel channel evolution is shown in Fig. 64.

In the previous sections, a number of reactor designs using heavy water moderation are described. It is obvious that, based on the pressure tube boundary conditions, the fuel channels can be divided into three types:

- Channels with a high temperature, high pressure boundary;
- Channels with a high temperature, low pressure boundary;
- Channels with a low temperature, moderate pressure boundary.

The aspects of fuel technology to be described in the various reactor designs will thus be addressed on the basis of the above divisions.

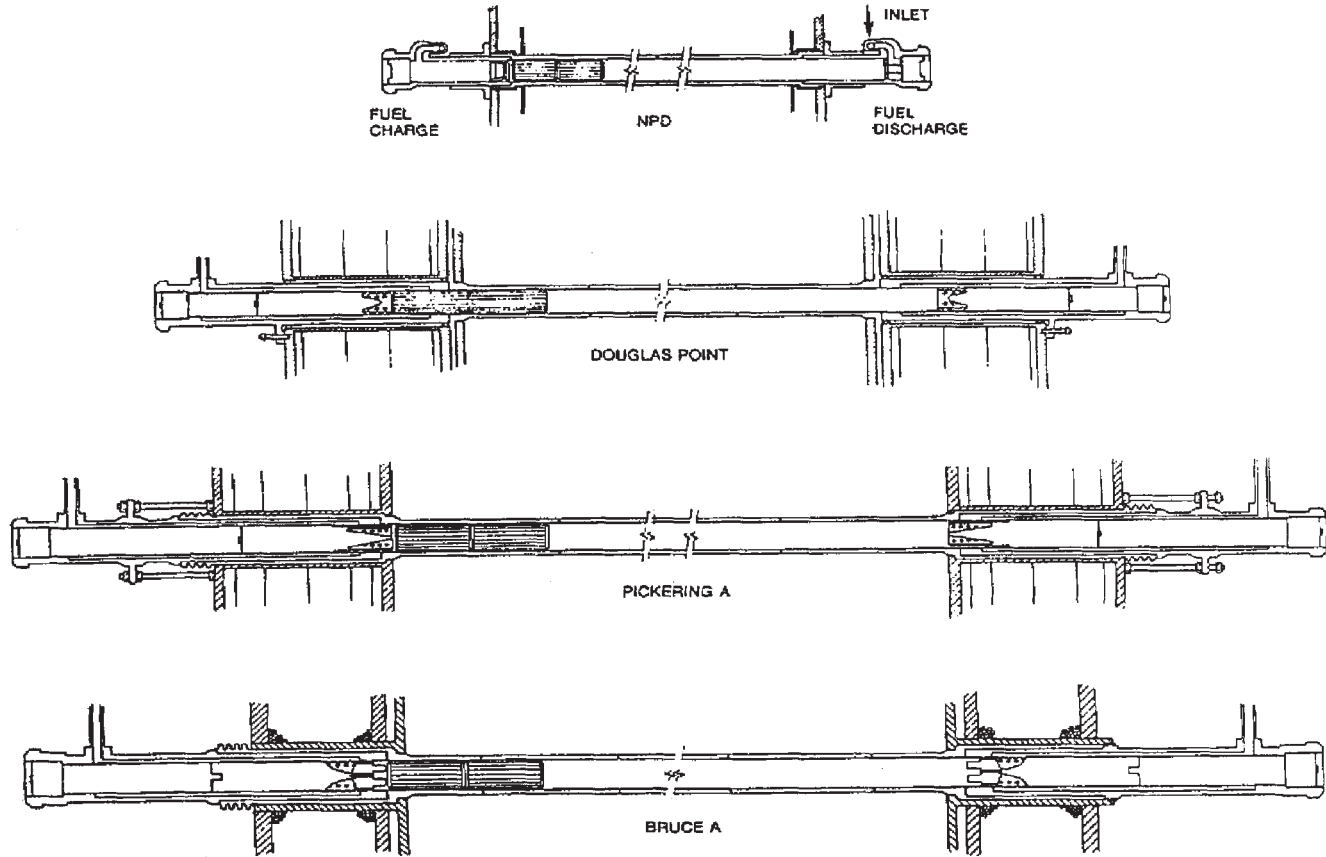

FIG. 63. The change in CANDU fuel channel design from prototype reactor to power reactor.

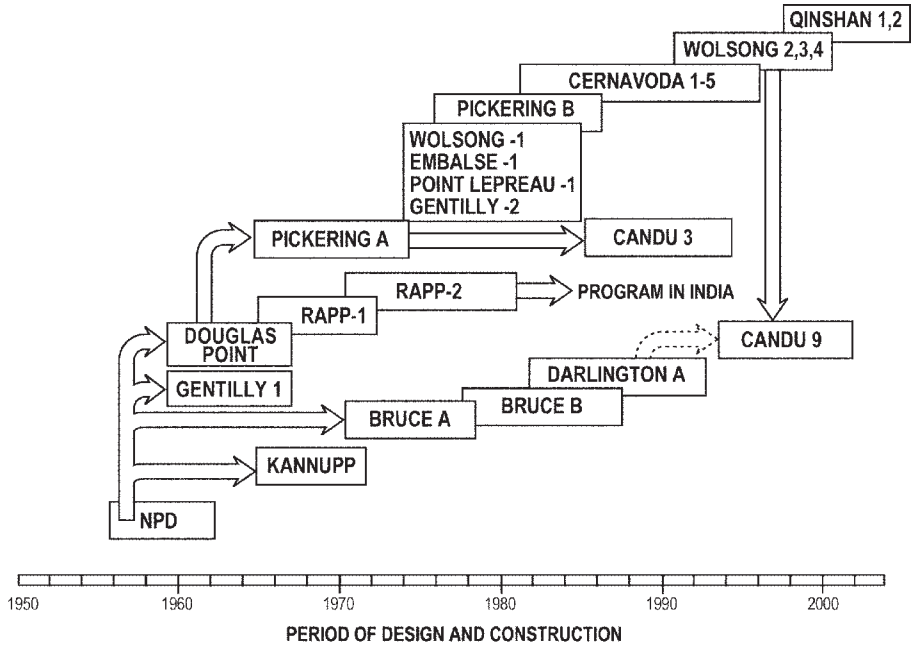

FIG. 64. Evolution of the CANDU fuel channel design.

3.5.1.2. Channels with a high temperature, high pressure boundary

(a) The CANDU 6 channel

The CANDU 6 fuel channel is shown in illustration in Fig. 65. It was derived from the Pickering A fuel channel, which in turn had its origins in the Douglas Point and NPD designs. The pressure retaining components are the pressure tubes, end fittings and closure seals. The Zr-2.5%Nb pressure tube (104 mm inside diameter, with a 4 mm wall thickness and 6.1 m long) is made from extruded, cold worked and stress relieved alloy. The tube is roll expanded into AISI type 403 stainless steel end fittings by a procedure that leaves low tensile residual stresses at the end of the rolled zone. The total length of the fuel channel, including the end fittings, is 10.1 m. The channel is accessed at each end for fuel removal and replacement. New fuel is inserted at the inlet end and used fuel removed at the outlet end. There are 12 bundles in each channel. Since the fuel is in the form of 37 element bundles (and soon to be used in 43 element bundles), the bundles can be stored in the rotating magazine of the fuelling machine before or after removal.

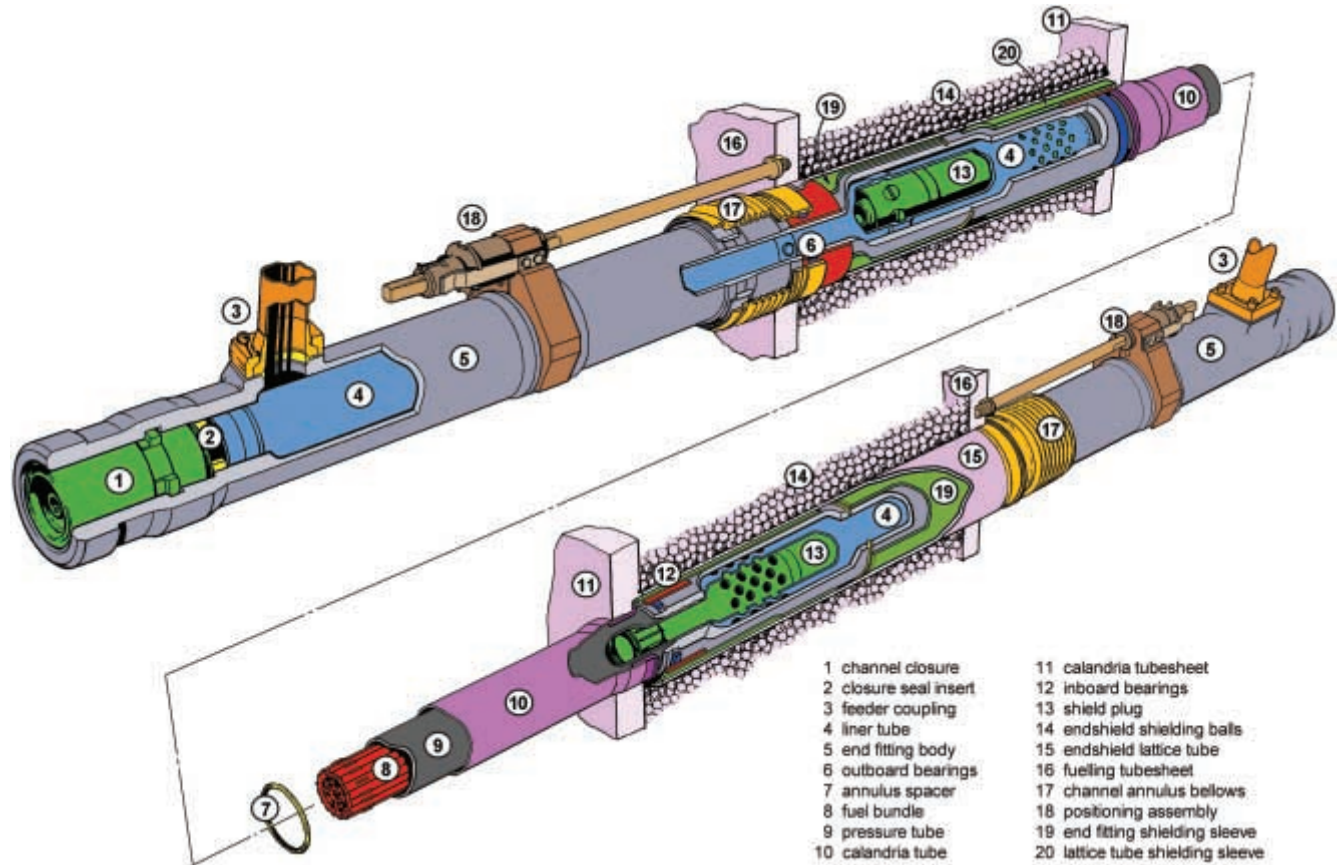

FIG. 65. Illustration of the CANDU 6 fuel channel.

The pressure tube and contents are supported by linear sliding bearings at each end of the reactor. The journal bearings are formed by ring bearings on the end fittings mating with sleeve bearings in the lattice tube. The in-core section of the pressure tube is supported by the surrounding calandria tube through toroidally coiled spacers which accommodate relative axial and diametral movement of the pressure tube and the calandria tube.

Positioning assemblies at each end of the channel position the channel in the reactor. Typically, the channel is positioned to allow elongation to take place on the full length of the bearings at one end by fixing the end fitting at the other end to the positioning assembly. At half-life, the channels are relocated by releasing the channel and pushing it to the inboard extremity of the unused bearing length and refixing it to the other positioning assembly. Each end fitting contains: (i) a liner tube to prevent the fuel bundles experiencing cross-flow on entering or leaving the fuel channel; (ii) a shield plug which supports the fuel at the outlet end and whereby flow is directed into the annulus between the liner tube and the end fitting body (and out through the side port) or from the liner annulus, through the shield plug and into the fuel without causing instability in the fuel; and (iii) a closure plug which can be opened by the fuelling machine. In the CANDU 6 channel, the seal forms part of a flexible dome that is pressed against a step in the end fitting in order to achieve a pressure face seal (Fig. 65).

In response to the neutron flux, high temperatures, water environment and wear, the channels (mostly the pressure tube) change as follows [48]:

- The dimensions change: the pressure tubes sag, expand and elongate. Typically, a CANDU 6 Zr-2.5%Nb pressure tube will expand more than 4%, elongate by 180 mm and sag up to 76 mm in the space of 30 years. The calandria tubes sag (and support the pressure tubes) and the pressure tube will sag between spacers but will not make contact with the calandria tubes.
- The pressure tubes pick up hydrogen as deuterium from corrosion and crevice reactions. The concentration of hydrogen after 30 years is predicted to be below the terminal solid solubility at operating temperatures and hydrides will only be present on cooldown. The surface oxide resulting from corrosion has no structural effect.
- The mechanical properties of the in-core components change as a result of the fast neutron flux damage. The strength increases and ductility and fracture toughness decrease to shelf levels which are acceptable for service. Recent developments in pressure tube technology have made the pressure tubes more resistant to decreases in fracture toughness caused by irradiation.
- The pressure tubes wear. Light scratching by fuel bundle movement can occur. Debris which can enter the channels from maintenance activities can become trapped in the fuel and wear the pressure tube through vibration in the flowing water.

Each of these types of change must be monitored by inspection of periodically removed pressure tubes. Debris fretting must be prevented by operating with a 'clean' HTS.

(b) The Bruce/Darlington fuel channel

The Bruce/Darlington channel is very similar to the CANDU 6 channel (with respect to pressure tube dimensions) but differs in a number of aspects.

New fuel is put into the channel at the outlet end and spent fuel removed from the inlet end. There are 13 bundles in each channel and the fuel string is supported at the outlet end by latches bearing on the circumference of the end plate. New fuel at the outlet end is pushed into the channel on a carrier tube in order to open the support latches. The shield plug has a slightly different design of the ports at the inboard end compared with the CANDU 6 shield plug. The closure plug design is also very different, being based on the breech block design of an artillery cannon (Fig. 66).

Instead of having positioning assemblies, one at each end of the channel, one end is welded in place and as a result channel repositioning activities are more complex. The channel operates at lower inlet and outlet temperatures of 260°C and 305°C respectively, than does the CANDU 6 channel.

(c) The fuel channel of the Indian PHWRs

The early fuel channels of Rajasthan units 1 and 2, and the Kalpakkam and Narora reactors were based on the design of the Rajasthan channel (Fig. 67), which was similar to the Douglas Point design. These designs were changed slowly, culminating in the design of the latest channel in Kakrapar 2 [23]. Cold worked Zircaloy 2 was used for the pressure tubes of the early reactors and this was changed to Zr-2.5%Nb for the Kakrapar 2 and succeeding reactors. Each pressure tube was 82.6 mm inside diameter and had a wall thickness of 3.94 mm.

The calandria tubes, initially seam welded Zircaloy 2, will be changed to a seamless, Zircaloy 2 type produced by pilgering for the 500 MW(e) design.

(d) The SGHWR fuel channel

A longitudinal section of the SGHWR fuel channel is shown in Fig. 68. The pressure tube was of Zircaloy 2 (a few Zr-2.5%Nb tubes were installed but were removed after a short operation when testing erroneously indicated that they would embrittle quickly). The pressure tube was reduced in diameter at the lower rolled joint where it was rolled into a hub which was, in turn, welded to the stainless inlet piping. In the upper part of the channel, the pressure tube was rolled into the hub of the upper standpipe which had a side port connected for the coolant outlet, the emergency cooling inlet and, at the top, the closure seal for refuelling.

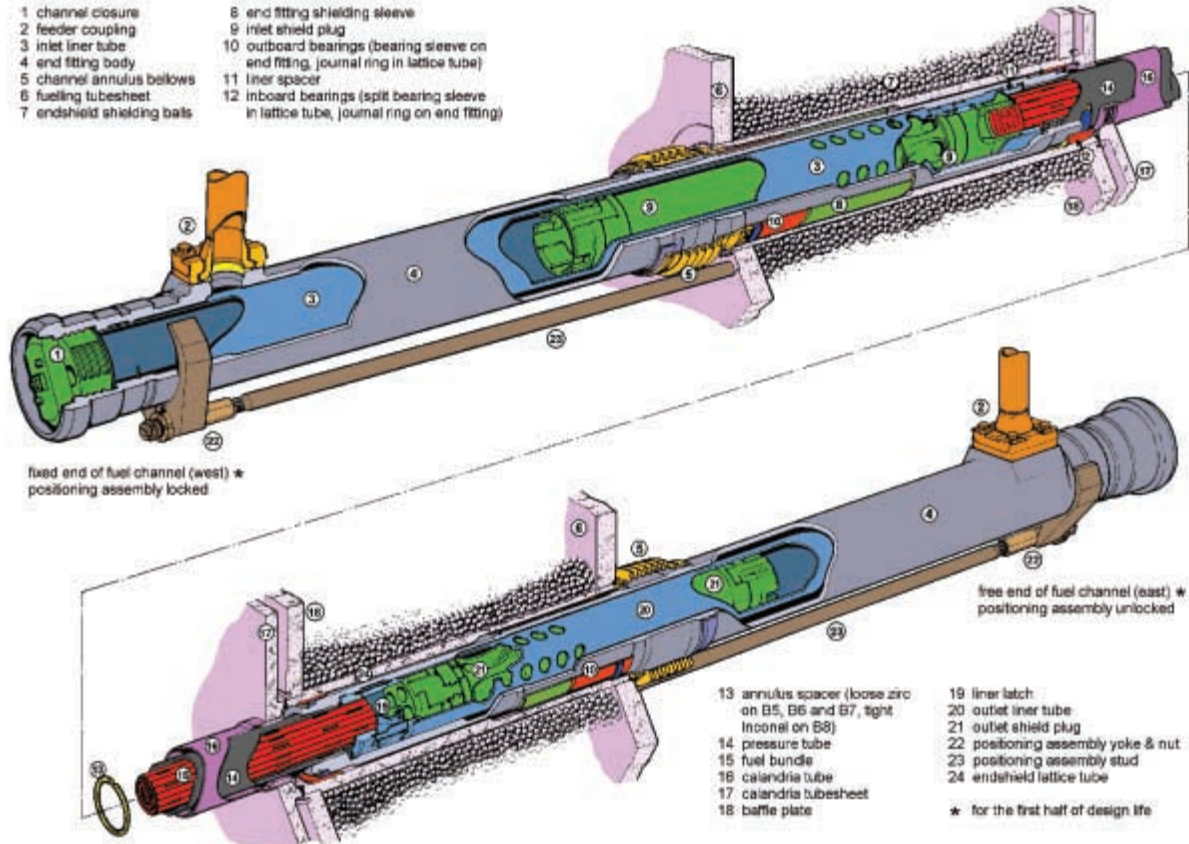

FIG. 66. Illustration of the Bruce type CANDU fuel channel.

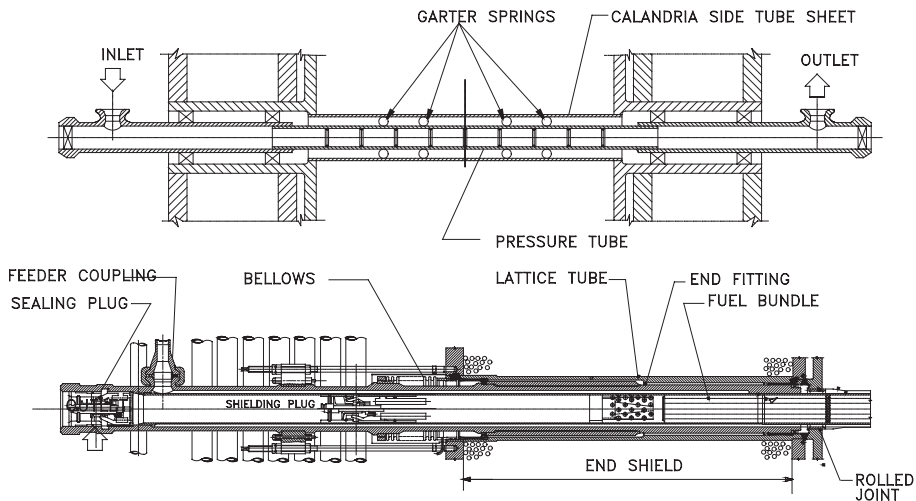

FIG. 67. Indian 220 MW(e) PHWR coolant channel assembly.

(e) The Gentilly 1 fuel channel

Figure 69 shows a longitudinal section through the Gentilly 1 fuel channel. The pressure tube was heat treated Zr-2.5%Nb alloy (103.5 mm inside diameter and 2.41 mm wall thickness). As a result of the thinness of the pressure tube wall, the pressure tube to end fitting rolled joint had to be made with an AISI type 410 insert that was roll deformed to hold the tube tight in the end fitting grooves. A similar joint connected the pressure tube to the upper end fitting. The calandria tube, flared to a larger diameter at each end, was of annealed Zircaloy 2 and was roll expanded with a 410 stainless steel insert into stainless steel upper and lower calandria extension tubes. The calandria tube was separated from the pressure tube by spacers supported on interlocking support rings. The fuel was attached to a central structural tube which was supported at the bottom and at the top by the lower and upper shield plugs respectively.

The channel was connected to the inlet and outlet feeders by a bolted Grayloc joint and split ring Grayloc joints respectively.

At the bottom, the channel closure plug sealed the end fitting with a bore seal achieved by deflecting a domed element outwards against the bore (cf. Fig. 67).

(f) The Fugen fuel channel

A longitudinal section of the Fugen fuel channel is shown in Fig. 70 [49]. The pressure tube is made of heat treated Zr-2.5%Nb, and is 117.8 mm in inside diameter

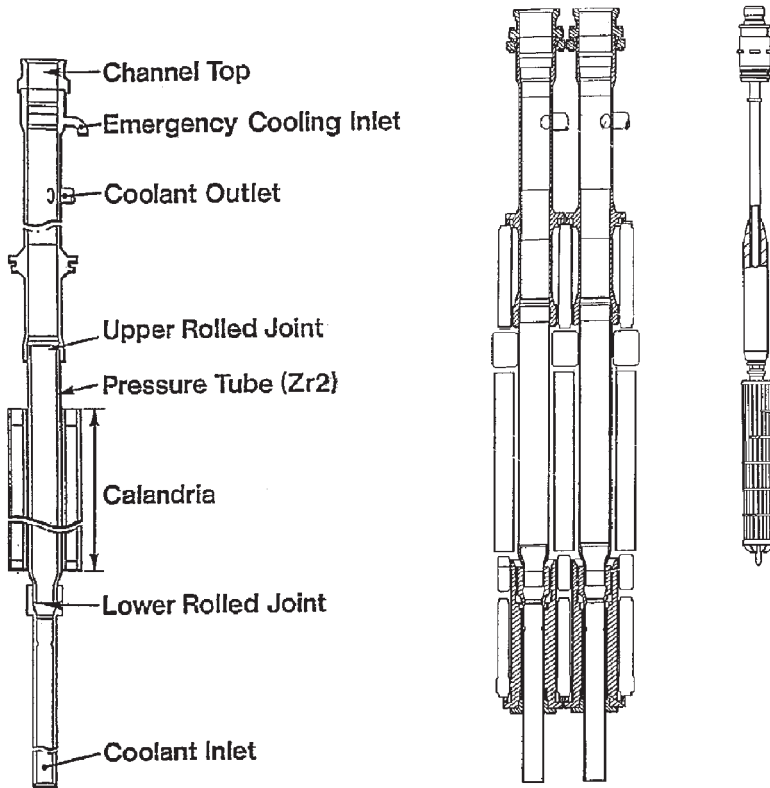

FIG. 68. The SGHWR fuel channel shown schematically and in detail.

and 2.2 mm in wall thickness. These dimensions and the alloy strength required the use of an insert at the rolled joint in order to maintain leak tightness.

The lower rolled joint has an internal insert to 'sandwich' the pressure tube between the insert and the end fitting. However, the upper end fitting sandwiches the pressure tube between an external insert and the end fitting (Fig. 71). An upper extension tube connects the channel to the external piping via a reducer. The connection to the inlet feeder is made via a side port and the closure plug at the bottom makes a bore seal with the end fitting extension using a flexed dome component [50]. The Fugen channel has functioned without problem.

(g) The Cirene fuel channel

The Cirene fuel channel is similar to the Gentilly 1 and Fugen channels. The pressure tube is made of Zircaloy 2 (106.1 mm inside diameter, 3.15 mm wall

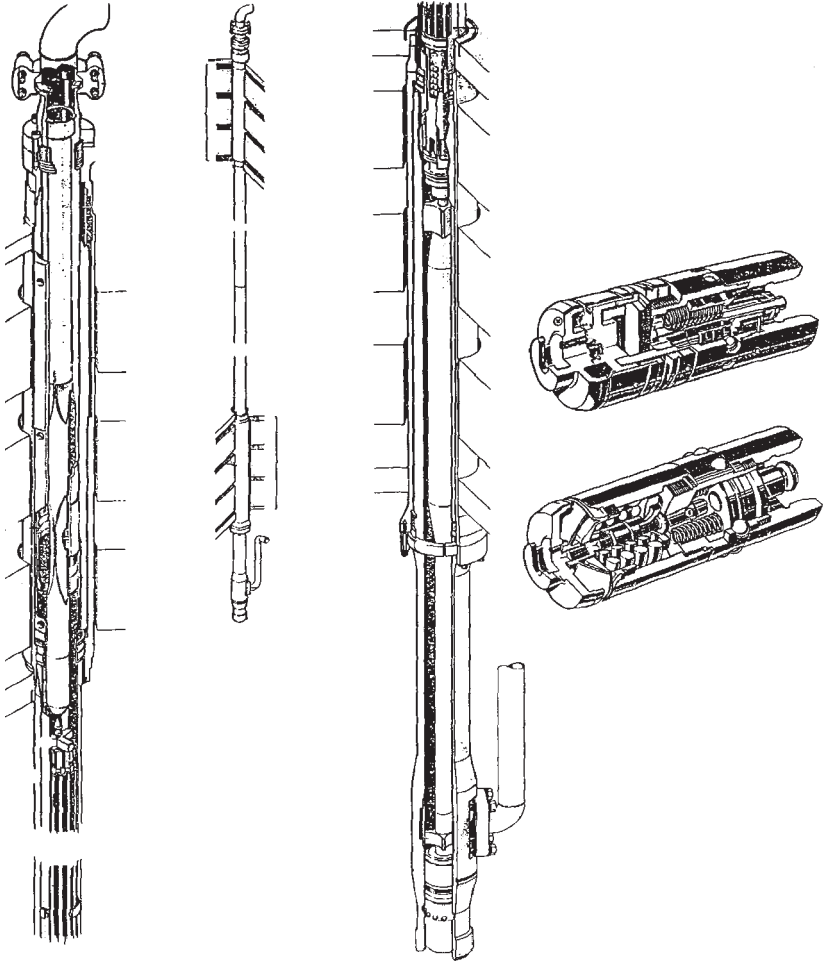

FIG. 69. Illustration of the Gentilly 1 fuel channel.

thickness). It is isolated from the moderator by a Zircaloy 2 calandria tube (124 mm inside diameter, 1 mm wall thickness), contact being prevented by coiled spacers supported on interlocking rings on the pressure tube located at the mid-core position.

3.5.1.3. Channels with a high temperature, low pressure boundary

As discussed in Section 3.3, fuel channel tubes (shroud tubes) in the Atucha pressure vessel water reactor operate with a small pressure differential between the coolant in the channel and the surrounding heavy water moderator.

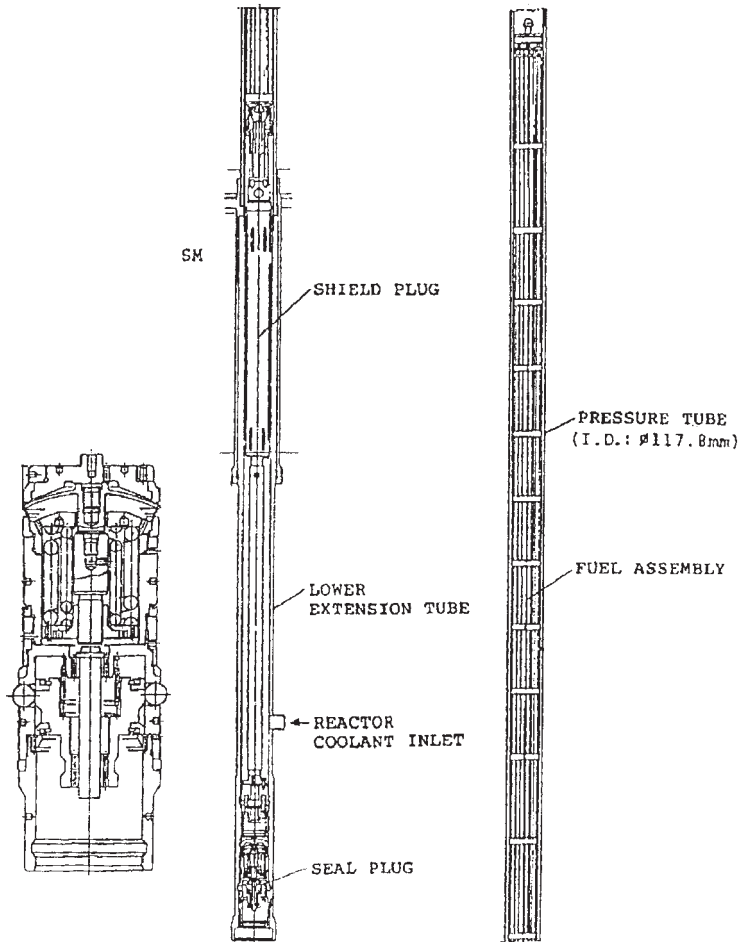

FIG. 70. Fugen fuel channel assembly and details of closure plug seal.

The entire channel is about 11 m long and consists of the central Zircaloy 4 channel and stainless steel ends. The upper stainless steel tube extends to the dome of the pressure vessel and has slots to allow the exit of the coolant into the upper plenum. The lower tube extends to the lower plenum. Both pass through the moderator tank, top and bottom, with small radial clearances. The stainless tubes have a hard surface coating in this region, which is water lubricated to allow for growth. The Zircaloy 4 shroud tube is roll expanded into both the upper and lower channel extensions at positions above and below the bottom and the top of the moderator tank.

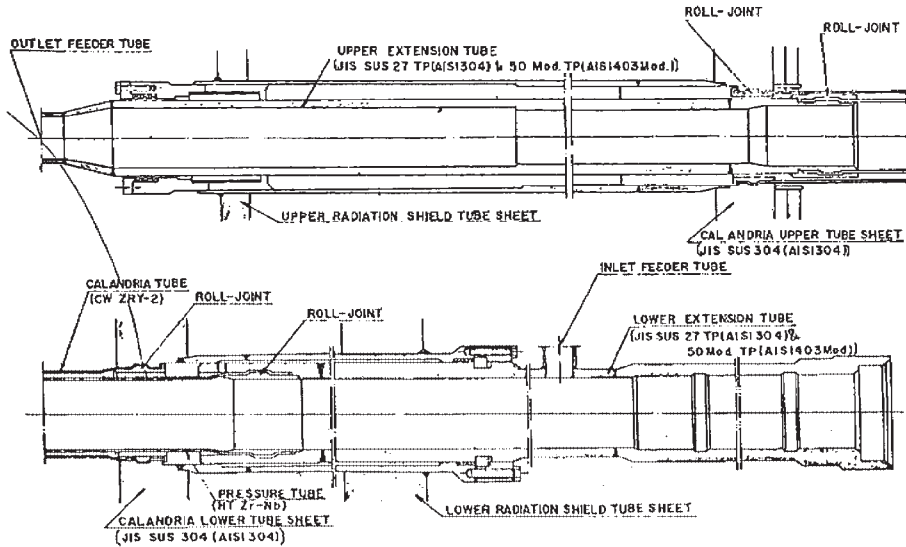

FIG. 71. Fugen fuel channel arrangement.

In the original design of the Atucha 1 tubes, the main shroud tube enclosing the fuel assembly is made of Zircaloy 4 and comprises a seam welded tube, 108.2 mm inside diameter and 1.6 mm or 1.72 mm in wall thickness. It is surrounded by a thin (0.1 mm wall thickness) Zircaloy tube, dimpled to maintain separation between the shroud tube and the seam welded Zircaloy 4 insulation tube (0.4 mm wall thickness). In the replacement channels of Atucha 1 and in Atucha 2, the Zircaloy 4 isolation tube has been eliminated in favour of a shroud tube and a surrounding insulation tube.

Longitudinal and transverse sections of the MZFR channel and a schematic diagram of the channel and the temperatures across the channel components of the MZFR, Atucha 1 and Atucha 2 are shown in Fig. 72 [11, 51].

3.5.1.4. Channels with a low temperature, moderate pressure boundary

(a) The EL 4 fuel channel

The pressure boundary tube of EL 4 channels comprises a Zircaloy 2 tube rolled into the end shields of the moderator tank. The tubes are 95 mm in diameter. Internally, the Zircaloy 2 pressure tube is a stainless steel guide tube with insulation positioned between the guide tube and the pressure tube. The guide tube is thus subjected to the temperatures of the CO₂ gas (235–475°C) and carries the fuel assemblies, whereas the pressure tube remains at the moderator temperature.

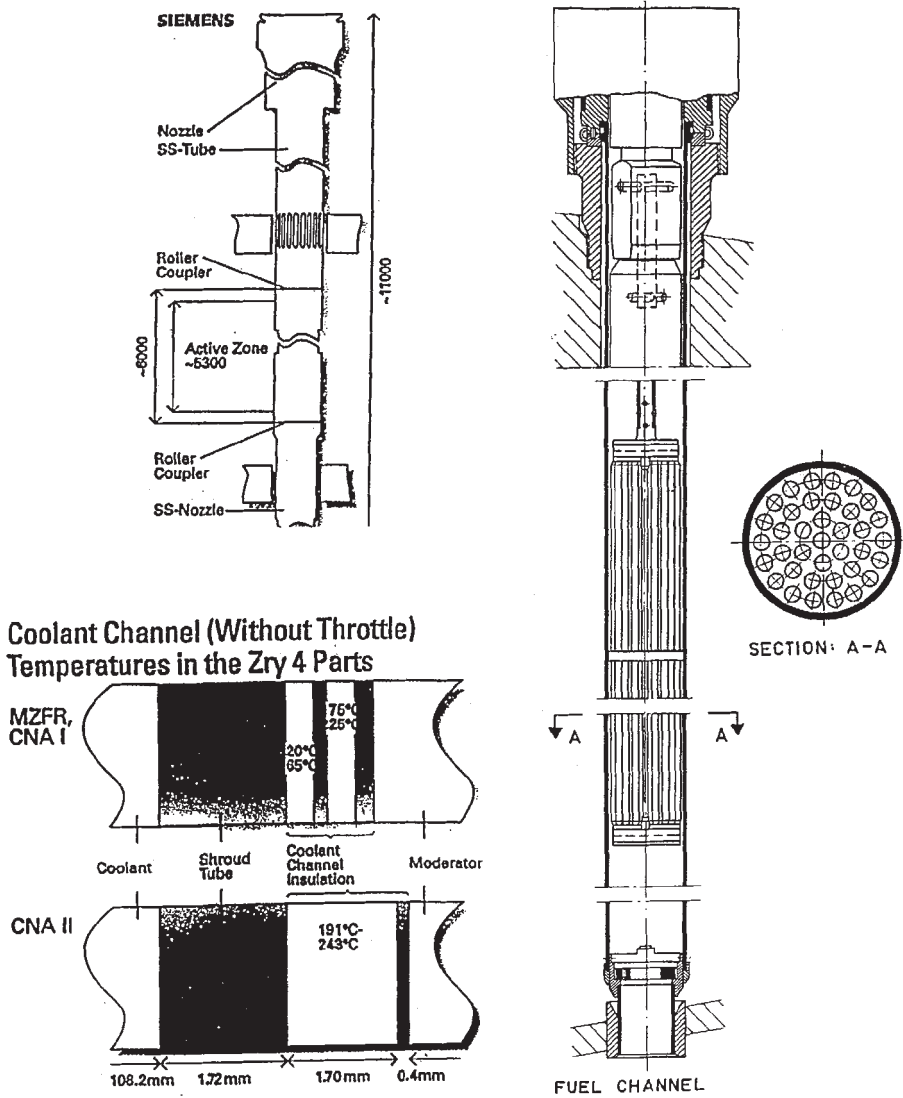

FIG. 72. Longitudinal and transverse sections of the MZFR fuel channel and a schematic diagram of the Atucha type fuel channel showing the typical radial temperature distribution in the shroud and insulating tubes.

Fuel Channel (Half Length)

- | | | |
|--------------------|-------------------------------|--------------------------------|
| 1. Safety Plug | 7. Thermal Plug | 13. Water Shield |
| 2. Latching Head | 8. CO ₂ Feeders | 14. Fuel Bundle |
| 3. Closure Seal | 9. Gas Exit Tubes | 15. Moderator D ₂ O |
| 4. Latch | 10. Welded Threaded Connector | 16. Pressure Tube |
| 5. Biological Plug | 11. Liner Extension | 17. Thermal Insulation |
| 6. Water Shielding | 12. Thrust Rod | 18. Guide Tube |

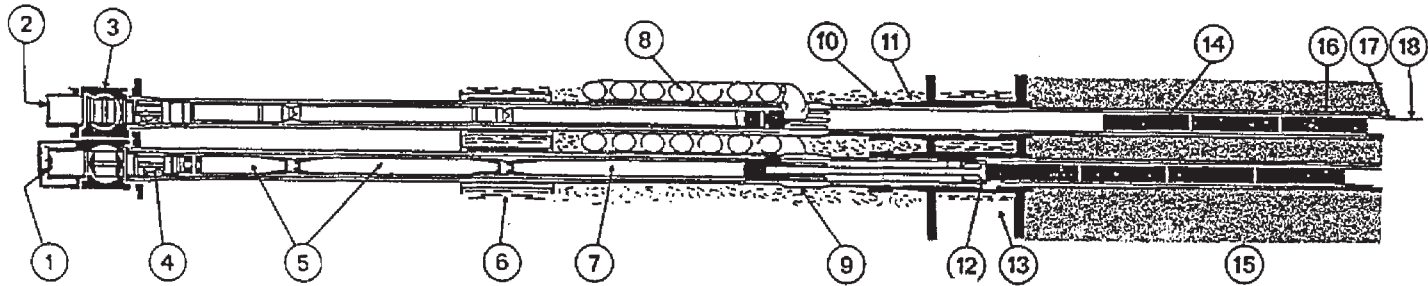

FIG. 73. Longitudinal half-section of the EL 4 fuel channel.

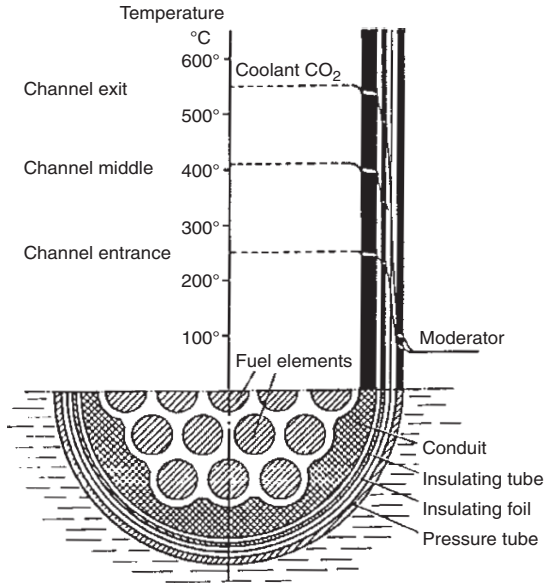

FIG. 74. Cross-section of the Niederaichbach fuel channel showing the typical radial temperature profile in the channel.

A longitudinal section of the EL 4 channel is shown in Fig. 73. Thermal plugs and biological shielding plugs occupy the channel extensions. The seal plugs at the channel ends incorporate a ball valve for fuelling machine access [14].

(b) The Niederaichbach fuel channel

A cross-section of the Niederaichbach channel is shown in Fig. 74. The pressure tube was made of Zircaloy 2 and was isolated from the hot CO₂ by a thin foil tube and an insulating tube of stainless steel. The pressure tube thus operated at moderator temperatures (<100°C).

(c) The Lucens fuel channel

In the Lucens fuel channel (Fig. 60, Section 3.4), the Zircaloy 2 pressure tube was kept to the temperature of the inlet CO₂ gas by passing the gas between the carbon matrix fuel and the pressure tube. An aluminium alloy calandria tube isolated the pressure tube from the moderator and low temperature CO₂ gas flowed through the annulus. The pressure tube thus operated at around 225°C [52].

The connections to the inlet and outlet piping could be disconnected by a handling machine above the reactor.

(d) The CVTR fuel channel

The fuel channels of the CVTR were made to a U-tube design, each leg containing one fuel assembly (Fig. 75). The pressure tubes were made of Zircaloy 2 (102 mm outside diameter, 6.1 mm wall thickness). The fuel contained in the pressure tube was isolated from the wall of the pressure tube by inner and outer circular thermal baffle tubes, 0.7 mm and 0.3 mm in wall thickness, respectively. In addition, a hexagonal flow baffle tube, positioned inside the thermal baffles, concentrated the flow through the fuel.

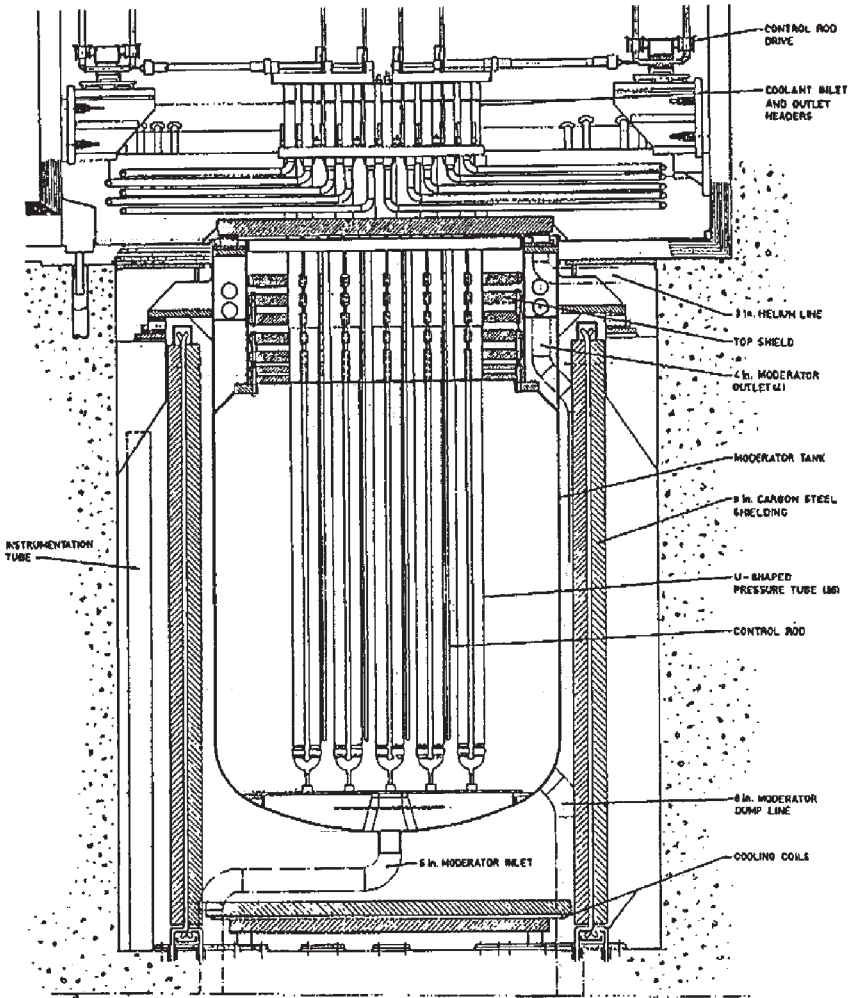

FIG. 75. The U-shaped fuel channels of the CVTR.

The pressure tube was in contact with the moderator water and heat shielded from the fuel, and thus operated in a cold pressurized condition. The pressure tube was rolled into the U-fittings at the bottom of the reactor and into end fittings at the top of the reactor [52].

The fuel consisted of 19 Zircaloy clad UO_2 fuel rods separated by a series of tubular spacers. An alternative design employed wire wrap around the rods as a means of achieving separation from each other.

(e) The KS150 fuel channel

The channel tubes were made of aluminium alloy and arranged on a square lattice pitch. The channel tubes were isolated from the fuel assembly by a protective internal magnesium alloy tube which surrounded 150–200 small diameter (4 mm) fuel rods of natural uranium arranged in 7 concentric rings around the centre rod. The fuel rod cladding was a 0.45 mm thick beryllium–magnesium alloy (Fig. 76).

3.5.2. Heavy water production and supply

3.5.2.1. Existing and historical heavy water supply

In the sixty-five years since its discovery, deuterium as heavy water has been produced in ten countries. Approximately 30 000 Mg has been produced, about 60% of this in Canada. Initial tonnage production was achieved by electrolysis in Norway in 1935 (still in production), followed by a plant in Trail, British Columbia, also using electrolysis and a catalyzed exchange of deuterium between hydrogen and water, with subsequent enrichment by electrolysis. Subsequent production by water distillation processes was undertaken in the USA, and followed in 1952 by two Girdler–sulphide ($\text{H}_2\text{S}-\text{H}_2\text{O}$) (GS) process plants, one at Dana, Indiana, and the other, comprising nine modules, at Savannah River. These plants were closed over the period 1957–1981. In the 1960s, Canada built two GS plants in eastern Canada which started production in 1970. India also commenced operation of a small hydrogen distillation plant in Nangal in 1961. In the mid-1970s, Canada started heavy water production at the Bruce A plant and India brought on line two NH_3-H_2 exchange plants at Baroda and Tutikorin. In the late 1970s, the Bruce B plant came into operation, again using the GS process, while India started up three medium sized plants, one based on the GS process, and two using the NH_3-H_2 exchange process. The large GS plant at Drobeta Turnu Severin in Romania also started operation in the late 1980s. In the 1980s, three GS plants in Canada ceased operation because of the surplus heavy water supply existing in the country.

In the 1990s, two heavy water plants in India commenced operation, as well as one in Argentina, whereas the remaining heavy water plant in Canada ceased operation.

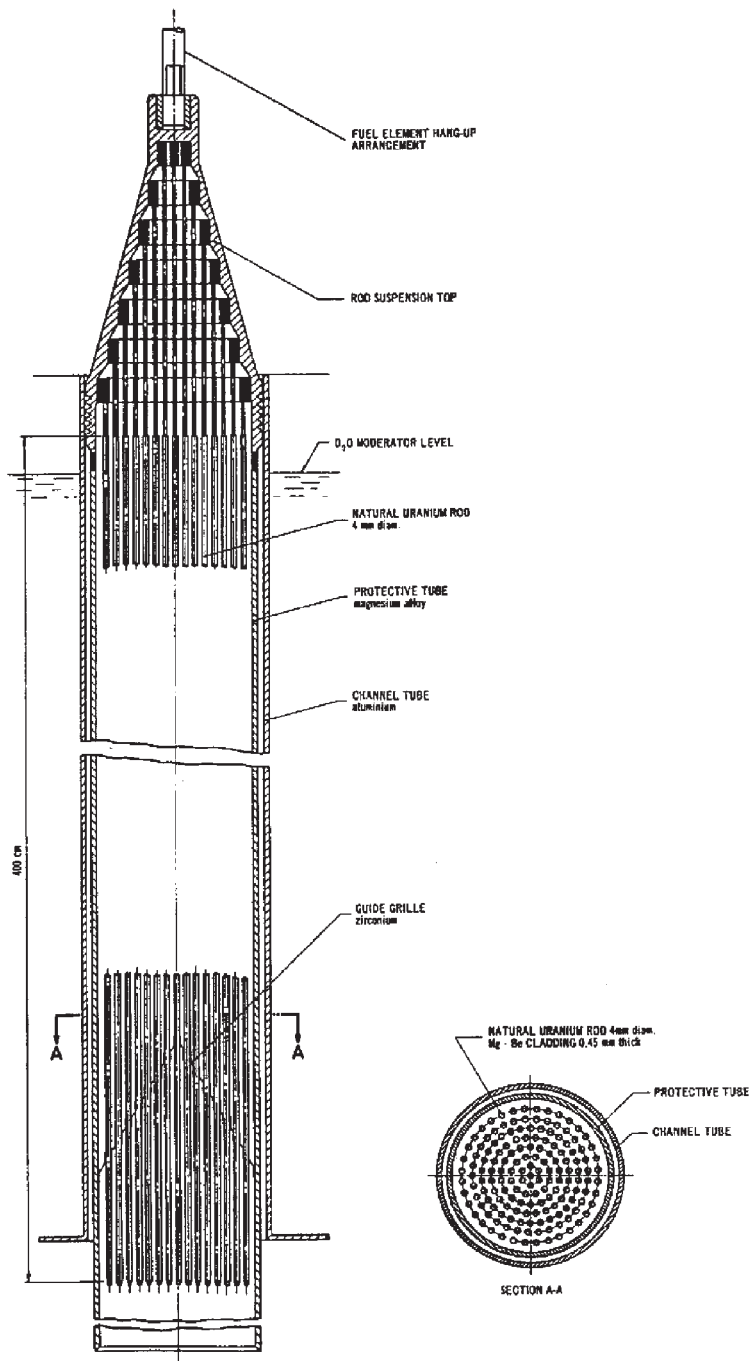

FIG. 76. Longitudinal and transverse sections through the KS150 fuel channel.

Table III lists the information available on previous and existing heavy water plants. A necessary feature of HWRs is their low rate of annual heavy water loss, typically <1% of inventory. Thus, heavy water make-up is a minor component of heavy water demand.

In Canada, AECL and OH between them own adequate amounts of heavy water to be able to supply new HWRs. AECL has loaned 1100 Mg of untritiated heavy water to the underground Neutrino Observatory in Sudbury (a multinational neutrino observation experiment). As existing heavy water stockpiles are ample to meet demand, AECL is developing new processes for lower cost heavy water production for the longer term.

3.5.2.2. Separation methods

Numerous reviews have been published on the merits of the diverse D₂O production processes [53]. All divergences between the isotopes of hydrogen, with respect to their physical or chemical behaviour, have the potential to lead to a separation process. The difference in any property on which an isotope separation process can be based is usually expressed as a separation factor, α , such that:

$$\alpha = \frac{[DX] \cdot [HY]}{[DY] \cdot [HX]}$$

where: [DX] is the deuterium concentration in one chemical or physical form
 [DY] is the deuterium concentration in the other chemical or physical form
 [HX] and [HY] are the corresponding protium or light hydrogen concentrations.

Note that at low concentrations of deuterium, the equation tends towards:

$$\alpha = \frac{[DX]}{[DY]}$$

A discussion of the myriad possibilities is beyond the scope of this review. However, it should be noted that a practical process must meet three exacting criteria: (i) as a result of the natural abundance of deuterium being so low, the feedstock must be abundant; (ii) as a consequence of this low abundance, large quantities of material must be processed and therefore processing must be kept relatively simple and should use a minimum of energy; and (iii) the separation factor pertaining to the properties of deuterated and protiated molecules, α , should be as far removed as possible from a value of unity (implying no separation), in order to reduce both the number of protium atoms that will separate with the deuterium rich stream and the number of deuterium atoms that will remain with the deuterium depleted stream, which is discarded.

TABLE III. HEAVY WATER PRODUCTION PLANTS

Country	Plant location/ designation	Process used	Year commissioned	Nameplate capacity and individual modules (Mg/a)	Actual average annual capacity (Mg)	Cumulative production (Mg)	Remarks
Argentina	Arroyito	NH ₃ -H ₂ exchange	1994	200 (2)	200	384	
Canada:							
	Hamilton	H ₂ O-H ₂ (CIRCE)	1999	1	1		Prototype
	Trail	Electrolysis	1941	6			Shut down 1956
	Glace Bay	H ₂ S-H ₂ O	1971	400			Shut down 1985
	Port Hawksbury	H ₂ S-H ₂ O	1966	400			Shut down 1985
	Bruce A	H ₂ S-H ₂ O	1969	800			Shut down 1984
	Bruce B	H ₂ S-H ₂ O	1973	800			Shut down 1997
China	NA	NA	NA	NA	NA	NA	NA
France:							
	Lacq	H ₂ S-H ₂ O exchange					
	Toulouse	Liquid H ₂ distillation					
India:							
	Nangal	H ₂ distillation	1962	14	NA	NA	
	Baroda	NH ₃ -H ₂ exchange (monothermal)	1977	45	NA	NA	
	Tutikorin	NH ₃ -H ₂ exchange (monothermal)	1978	49	NA	NA	

TABLE III. (cont.)

Country	Plant location/ designation	Process used	Year commissioned	Nameplate capacity and individual modules (Mg/a)	Actual average annual capacity (Mg)	Cumulative production (Mg)	Remarks
	Kota	H ₂ S–H ₂ O exchange	1984	85	NA	NA	
	Talcher	NH ₃ –H ₂ exchange (bithermal)	1985	62.5	NA	NA	Not operational
	Thal	NH ₃ –H ₂ exchange (monothermal)	1987	110	NA	NA	
	Hazira	NH ₃ –H ₂ exchange (monothermal)	1991	110	NA	NA	
	Manuguru	H ₂ S–H ₂ O exchange	1992	185	NA	NA	
Norway	Rjukan	Electrolysis	1935	20 (14)	NA	NA	
Romania	Drobeta Turnu Severin, Mehedinti	H ₂ S–H ₂ O isotopic exchange	1987 (4 modules at 90 Mg/a)	270	132–150	685	Only three modules can be operated together
Russian Federation							None in operation
USA:							
	Columbia River	H ₂ O distillation	1944	~10		21	Shut down 1945
	Columbia River	H ₂ O distillation	1944	~10			Shut down 1945
	Morgantown	H ₂ O distillation	1943	4.8	~3.5		Shut down 1945

TABLE III. (cont.)

Country	Plant location/ designation	Process used	Year commissioned	Nameplate capacity and individual modules (Mg/a)	Actual average annual capacity (Mg)	Cumulative production (Mg)	Remarks
	Childersburg	H ₂ O distillation	1943	9.6	~3.1	22.8	Shut down 1945
	Newport	H ₂ O distillation	1943	14.4	~8.0		Shut down 1945
	Dana	H ₂ S–H ₂ O exchange	1952				Shut down 1957
	Savannah River	H ₂ S–H ₂ O exchange	1952				Shut down 1981

Note: NA — not available.

3.5.2.3. Processes based on chemical exchange

A small group of chemical exchange processes meets these criteria for economic viability and this group has dominated and appears likely to continue to dominate heavy water production. These processes all involve transfer of hydrogen isotopes between two hydrogen containing chemical species, X and Y. They can be described, in the most general way, as:

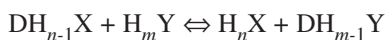

Table IV summarizes factors of significance in the relative merits of the main contending processes.

Figures 77 and 78 illustrate the two types of process that can be employed: monothermal and bithermal. In a monothermal process, isotope exchange is performed at the lowest practicable temperature (where the separation factor is invariably larger); the liquid species must be converted to the gas species and there

TABLE IV. PARAMETERS OF PRINCIPAL IMPORTANCE FOR A HEAVY WATER PRODUCTION PROCESS

Factor under consideration	Chemical pair		
	H ₂ S–H ₂ O	NH ₃ –H ₂	H ₂ O–H ₂
Catalyst requirement	None	Soluble KNH ₂	Heterogeneous wetproofed Pt
Possible temperature range (°C)	28.5--145	-77.7--60	0--200
Possible separation factor range	2.34--1.78	9.41--2.96	4.50--2.00
Practicable temperature range (°C)	28.5--130	~30--±60	25--170
Reason for lower temperature bound	Forms solid hydrate	Kinetics too slow	Kinetics too slow
Reason for higher temperature bound	Total pressure limited by H ₂ S liquefaction; vapour pressure of H ₂ O limits	Vapour pressure of NH ₃ limits; 35 MPa required at 60°C	Catalyst stability limits
Practicable separation factor range	2.34--1.82	5.43--2.96	3.80--2.14
Practicality of a monothermal process	No	Yes	Yes
Feed	Water	Hydrogen	Water or hydrogen

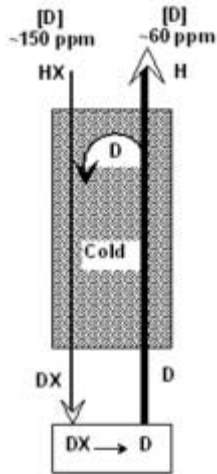

FIG. 77. Schematic diagram of a monothermal process.

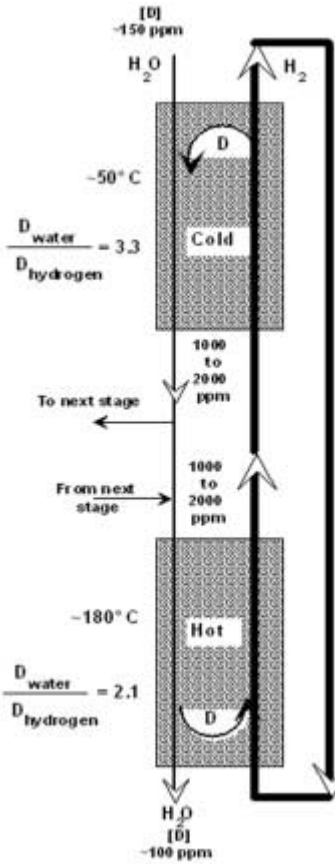

FIG. 78. Schematic diagram of a bithermal process.

may be a requirement to reconvert the gas to the liquid. Deuterium is transferred from the gas to the liquid and the liquid leaving the exchange column is converted into gas having the same deuterium concentration (because the conversion is essentially total).

For the chemical pairs listed in Table IV, it is practical to convert ammonia to hydrogen by thermal cracking (and, if necessary, to convert hydrogen back to ammonia by standard ammonia synthesis techniques). Similarly, water can be converted to hydrogen either by steam reforming of hydrocarbons or by electrolysis (and, if necessary, hydrogen can be reconverted to water by burning or catalytic recombination). There are no practical chemical reactions to interconvert water and hydrogen sulphide and therefore the $\text{H}_2\text{S}-\text{H}_2\text{O}$ pair must depend on a bithermal process (Fig. 78).

In a bithermal process, the operation of the cold tower is similar to that of the monothermal process: water becomes enriched in deuterium; hydrogen becomes deuterium depleted. However, the water leaving the cold exchange column is now subjected to further exchange in a hot (lower) column. With a lower separation factor at higher temperatures, some deuterium is driven back from the liquid to the gas. Even though the concentration of deuterium in the gas leaving the hot tower and entering the cold tower is lower than that of the liquid leaving the cold tower, it can still be high enough to drive deuterium from the gas to the liquid in the cold tower.

3.5.2.4. *Process dependence on kinetics*

Weighing the relative merits of the practical processes can reasonably be considered in terms of kinetic considerations versus all other factors. The process first used for large scale D_2O production was the GS process. This is based on exchange between liquid water and hydrogen sulphide. The GS process is a contender only because it has excellent kinetics, the result of a fast, ionic, exchange reaction with no need of a catalyst. In many other respects, this is not an attractive process since hydrogen sulphide is toxic and corrosive and the water–hydrogen sulphide system has relatively small separation factors. A small separation factor results in large process flows and large energy consumption.

As alternatives to GS, both monothermal and bithermal processes based on ammonia–hydrogen exchange have been developed and deployed. In order to achieve large separation factors and avoid the use of very high pressures, these processes must operate at substantially subambient temperatures. A catalyst is required and the best catalyst known is the potassium salt of ammonia, KNH_2 , a soluble, homogeneous catalyst. Even with the catalyst, the resulting kinetics are quite slow and its performance is usually enhanced by mechanical agitation. A variant bithermal system based on aminomethane, CH_3NH_2 , and an analogous alkali metal catalyst, CH_3NHK , were developed in the 1970s by AECL. As it provides faster kinetics and its vapour pressure is lower at a given temperature than that of ammonia, this process is

considered to be marginally superior to processes based on ammonia. Despite this, however, it has never been commercialized. As the interconversion of hydrogen and aminomethane is not practicable, only a monothermal process could be used.

The majority of plants currently in operation around the world use the ammonia–hydrogen catalytic exchange process. Several small GS plants are also in operation. However, both ammonia–hydrogen and GS processes require large capital expenditure. Despite the excellent performance of large scale GS technology in Canada (after initial technical problems had been resolved), forecasts of the cost of heavy water produced in new plants using GS and ammonia based processes are sufficiently high to stimulate the deployment of new technologies for heavy water production.

The relative merits of the third chemical exchange system, water–hydrogen, have long been appreciated. Its separation factor is comparable to that of ammonia–hydrogen, while its optimal operating temperature range is modestly above ambient. Only one major obstacle has stood in the way of using water–hydrogen exchange — the absence of an effective catalyst for the isotope exchange reaction. Various catalysts were known but only platinum appeared capable of achieving fast enough kinetics to be effective at near ambient temperatures. Unfortunately, platinum could only be used in the absence of liquid water because, as a solid, heterogeneous catalyst, the rate of diffusion of hydrogen through liquid water towards the platinum catalyst sites is exceedingly slow. A configuration where hydrogen and water are both in the gas phase is not useful since counterflow of the two components is essential to achieving useful changes in the concentrations of the two species.

One possible solution in the form of a heterogeneous catalyst using wetproofed platinum was conceived by AECL in the late 1960s. The concept employs a trickle bed reactor, combining wetproofed platinum and wetttable hydrophilics in one structure. The wetproofing maintains access of hydrogen and water vapour in the upflowing gas phase to the platinum exchange sites in the presence of a liquid water downflow. Subsequent development has now reached a point at which the performance of this catalyst justifies the prototyping of processes.

3.5.2.5. Processes based on water–hydrogen exchange

The attractiveness of processes based on water–hydrogen can be understood by reference to Fig. 79, which shows that the separation factor for the water–hydrogen system is both much larger and varies much more strongly with temperature than for the water–hydrogen sulphide system of the well-established GS process [54]. Development of an effective catalyst is, however, a prerequisite for exchanging hydrogen isotopes between water and hydrogen. AECL has successfully developed a high activity, stable, trickle bed catalyst that is based on wetproofed platinum and

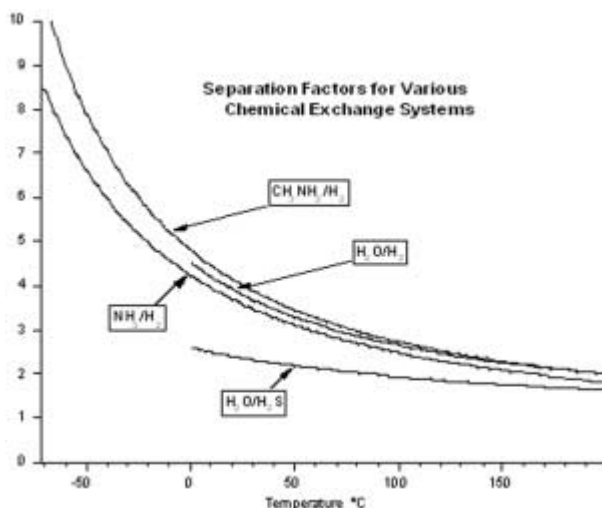

FIG. 79. Separation factors for the main chemical exchange systems as a function of temperature.

where the two steps of exchange, (i) hydrogen to water vapour and (ii) water vapour to liquid water, can occur side by side. This provides a very simple system for the maintenance of countercurrent flow of hydrogen/water vapour and of liquid water.

In order to combine high activity with low pressure drop, AECL uses a structured catalyst made from plates of stainless steel, wire mesh screen. This comprises alternating plates of hydrophilic material (to exchange deuterium between liquid water and water vapour) and platinum bearing, hydrophobic material (to exchange deuterium between hydrogen and water vapour).

The catalyst is potentially susceptible to loss of activity through poisoning of the platinum sites. The poisoning agents of greatest practical concern are carbon monoxide, a common contaminant of hydrogen streams, and organic impurities in water streams. These are quantitative poisons and therefore their effects are easily observed in small test samples. However, they become less observable and less important in industrial applications where the amounts of catalyst are large. Catalytic activity can also be restored by exposing the catalyst to oxygen at temperatures exceeding 100°C. Although catalytic poisoning becomes less important with deep catalyst beds, maintenance of good water distribution within deep beds of structured catalyst becomes increasingly important. AECL's catalyst development programme has mastered this requirement through a design detail of the structured packing.

In the last five years, catalyst development has increasingly been focused on applying the catalyst to process conditions of practical importance in heavy water production, i.e. higher temperatures (up to 170°C) and much higher pressures (1–4 MPa). Catalysts having good stability up to 170°C have been successfully tested

and show no evidence of thermal degradation. As one would expect, there is an inverse correlation of catalytic activity with pressure. This, however, has become significantly weaker in its effect than that previously measured, improving the economics of all high pressure process applications of the catalyst.

3.5.2.6. Process applications

(a) The combined electrolysis and catalytic exchange (CECE) process

By far the simplest approach for harnessing water–hydrogen exchange is via CECE. This process is illustrated in Fig. 80. However, despite its simplicity, the cost of electrolytic conversion of the entire feed stream from water to hydrogen remains an obstacle to the large scale deployment of this process for heavy water production. However, in cases where large scale electrolysis is already being used to produce hydrogen on a very large scale (in excess of 100 MW), a CECE addition to produce D_2O would be economic. While installations of this magnitude are rare nowadays, this could change if the capital cost of electrolysis cells were to be reduced. To that end, one company's objectives are "to supply electrolytic hydrogen generators with a 'footprint' of about one tenth of the present, with a weight of about one tenth of the present and — by far the most important — with a capital cost, at high manufacturing volume, of about one tenth of the present" [55]. The same company envisages these cells being deployed "in blocks of 25 to 100 MW and multiples thereof for centralized

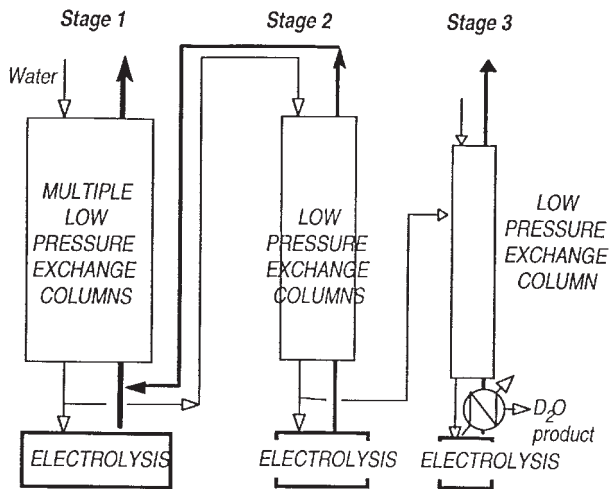

FIG. 80. Simplified schematic diagram of a CECE process.

hydrogen production” [56]. Should the capital cost of electrolysis fall sufficiently, large electrolytic complexes producing hydrogen, oxygen and heavy water could become economic in cases where relatively low cost electric power is available. However, until then, CECE will offer only a niche opportunity for small quantities of low cost D_2O production.

The more immediate potential for applications of the CECE process involves the upgrade of downgraded reactor heavy water and the separation of tritium from light or heavy water. In order to demonstrate these applications, AECL is now operating a small prototype plant at its Chalk River Laboratories, the CECE upgrading and detritiation (CECEUD) demonstration. This plant is currently operating as an upgrader for removing light water contamination from heavy water. As is usually done with upgraders, the plant has a single stage with a very large concentration range. The CECEUD is routinely producing a bottom product of 99.99 mol% and an overhead concentration below the natural deuterium concentration. This provides additional validation of the concept of using a wetproofed catalyst in a trickle bed mode rather than using the more complex concept of separated beds in which contact between gas and vapour over a catalyst repeatedly alternates with contact between gas/vapour and liquid water. The separated bed is a long established concept, initially used at Trail, British Columbia, in 1943 [49]. However, it appears that wetproofed catalyst technology in trickle beds has now firmly displaced the separated bed approach.

In early 1999, the CECEUD was switched to the demonstration of detritiation of heavy water. Limiting the gradual rise of tritium concentrations by detritiation is considered an optional procedure for CANDU owners. OH, for example, operates the Darlington tritium removal plant in order to extract 97–98% of the tritium content from heavy water and thereby limit the concentration of tritium in the heavy water of its CANDU reactors [57]. More complete detritiation can, however, serve a somewhat different purpose than recycling used heavy water by restoring it to a low enough tritium concentration to make it equivalent to new water. The CECE process is particularly well suited to this detritiation application because of its large separation factors (e.g. 1.67 between tritium and deuterium at 25°C). Consequently, the cost of detritiation by this process is only weakly linked to the magnitude of detritiation. With the demonstration of this application of CECE technology, the reuse of heavy water at the end of life of a reactor becomes a useful supplement to new production.

(b) The combined industrially reforming and catalytic exchange (CIRCE) process

In the absence of widespread access to production of D_2O by the CECE process, AECL's plans for a new, advanced technology for heavy water production are based on another synergistic process known as CIRCE. This process harnesses

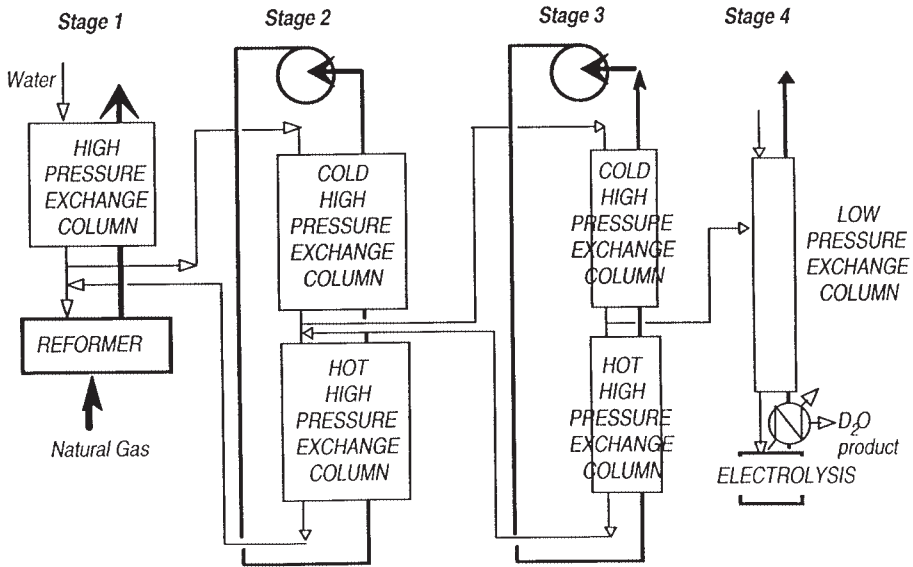

FIG. 81. Simplified schematic diagram of a CIRCE process.

water–hydrogen exchange to hydrogen production by steam reforming. The process is illustrated in Fig. 81. Strictly, the CIRCE process is used only for the first stage of heavy water extraction and enrichment (to around 0.6% D_2O). As illustrated in Fig. 81, this first stage is followed by three other stages of further deuterium enrichment. Enrichment to around 10% is achieved in two stages of bithermal water–hydrogen exchange. This is a change from the previous perspective in which these middle stages were envisaged as using the CECE process. Advances in bithermal technology now make it a more attractive technology for use in these middle stages. The final stage, however, that of producing reactor grade D_2O (>99.72% purity), continues to employ CECE technology. This is done because a monothermal process is much less perturbed by the effects of heat of reaction, which are experienced when deuterium concentrations change rapidly in a countercurrent process, and by variation of the effective separation factor at elevated concentrations. The final stage is small and the difference in cost between process options is unimportant.

As with CECE, CIRCE is a monothermal process, but conversion of hydrogen to water is achieved by steam reforming. This introduces several complexities when compared with the CECE process. These are summarized in Table V.

The first two complexities are unavoidable. The third is plant specific. Figure 82 shows one set of changes that would adapt CIRCE to a design of steam

TABLE V. FACTORS OF RELATIVE COMPLEXITY FOR THE CIRCE PROCESS

Complication	Consequences
Hydrogen isotope exchange must take place at the high pressure of the reformer (typically 1–3.5 MPa).	Activity of wetproofed catalysts is found to decline somewhat with increase in pressure.
Water flow provides only half the hydrogen generated in the reformer.	Water must extract twice as much deuterium from the hydrogen stream as the water flow in the CECE process, which means reduced concentration differences and longer columns.
Reformer becomes the equivalent of the electrolytic cell of the CECE process.	The reformer contains elevated levels of deuterium, which means that losses of any deuterated species (H_2 , H_2O , CH_4) must be maintained at low levels. Low CH_4 concentrations (<1000 ppm) in the H_2 stream are particularly important since the catalyst does not exchange hydrogen isotopes between water and CH_4 , but exchange does occur in the reformer.
Steam reformed hydrogen usually contains traces of CO (Pt catalysts are poisoned by CO).	CO must be removed, either by shift conversion to CH_4 (though, again, the resultant total CH_4 level must remain <1000 ppm in order to avoid unacceptable losses of deuterium as CH_3D), or be absorbed on a guard bed ahead of the main exchange column.

reformer that uses pressure swing absorption for hydrogen purification (these are the actual modifications made to the prototype plant discussed below). The fourth complexity can be dealt with generically and AECL has developed highly effective methods, using either CO absorption or methanation, of reducing CO concentrations to levels that are undetectable and which have no demonstrable effect on the exchange catalyst.

Although it is obviously more complex than the CECE process, the main attraction of the CIRCE approach to D_2O production is the widespread availability of large steam–methane reformers (SMRs) producing hydrogen. Each 1000 Mg/d ammonia plant, for example, has the capacity to produce over 50 Mg/a of heavy water and the production cost is expected to be lower than all other technologies except CECE.

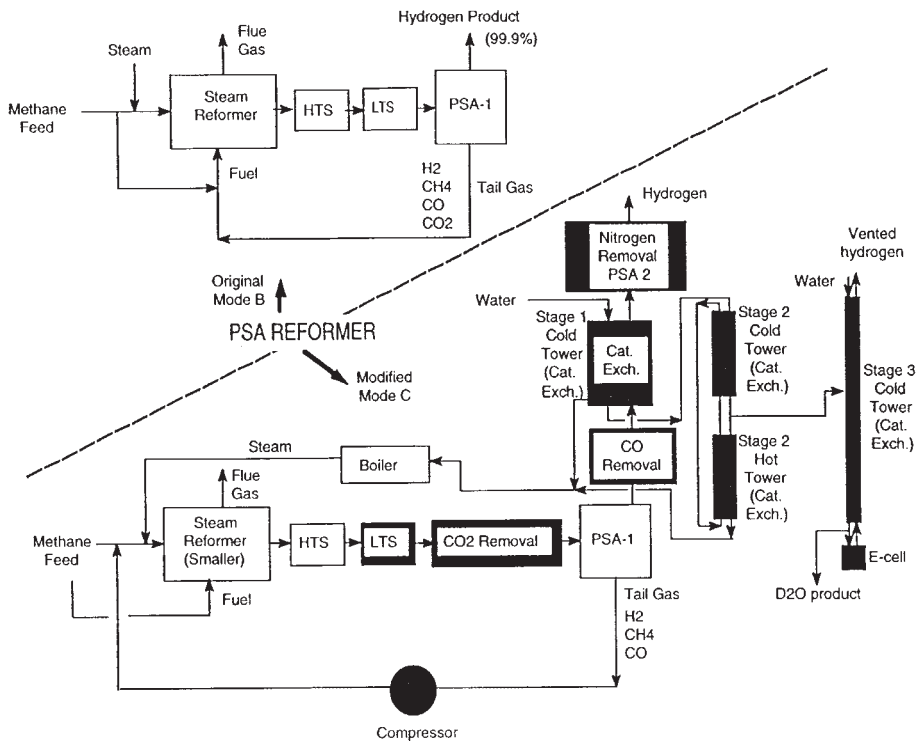

FIG. 82. Illustration of a steam reformer using pressure swing absorption, both unmodified and modified, to accommodate a CIRCE plant.

With the commitment of two prototypes, AECL has begun the industrial demonstration of CIRCE technology. The first of these plants has just completed commissioning. This is the Side Stream Test Facility (SSTF), located at an Air Liquide Canada site in Edmonton, Alberta. The SSTF will meet two principal objectives: it will (i) demonstrate the removal of CO traces from SMR produced hydrogen and (ii) demonstrate the lifetime and performance of the exchange catalyst in an industrial environment.

AECL's second plant is a complete prototype CIRCE plant (PCP), built in conjunction with a small SMR owned by Air Liquide Canada in Hamilton, Ontario. The SMR is designed to produce $0.72 \text{ m}^3/\text{s}$ (equivalent to $62\,260 \text{ m}^3/\text{d}$) of hydrogen and the CIRCE plant will produce 1 Mg/a of D_2O . Design and construction of the SMR and the PCP were fully integrated. The PCP deploys all of the technology that

would be needed for any full-scale CIRCE plant. It has a second stage that uses bithermal water–hydrogen exchange and a CECE third stage. The adaptations to this SMR are extensive; other SMRs are expected to require less extensive adaptations.

Construction of the SMR and the modifications needed to adapt it for CIRCE attachment were completed in November 1998. Construction of the PCP was completed early in 2000, and the plant declared in-service in July 2000. The combination of low market demand for hydrogen and operational problems with both the SMR and the PCP meant that buildup of deuterium in the PCP was slow; first reactor grade product being achieved in March 2001. The three stages of the PCP are functioning as intended and the integration of the two plants is complete.

CIRCE is expected to achieve the lowest cost of production for heavy water available from a new production plant. It is seen as possessing the additional advantage of being naturally a relatively small scale process. As such, it is well suited either to provide make-up for a group of CANDUs or to facilitate a lease–replace arrangement whereby a country committing CANDU reactors would commit a CIRCE plant at the same time and would gradually replace an initial charge of leased D₂O with its own ongoing D₂O production.

(c) Bithermal water–hydrogen technology

A stand-alone plant based on bithermal water–hydrogen exchange is technically possible but appears to be significantly more expensive than CIRCE technology. A bithermal water–hydrogen plant using hydrogen, rather than water, is also feasible and appears to have economics intermediate between those of a water fed bithermal water–hydrogen plant and CIRCE.

3.5.2.7. *Summary*

AECL intends to base future heavy water production on water–hydrogen based processes using its proprietary wetproofed catalyst. Work on the catalyst has progressed well and it now provides the performance required for an economic CIRCE process.

AECL's emphasis is on the monothermal CIRCE process, supplemented wherever opportunities arise by the CECE process. By deploying both CIRCE and CECE processes in Canada and in other countries, this programme will ensure continuing supplies of heavy water for CANDU reactors sufficient to meet any conceivable demand for heavy water at a cost that maintains the competitiveness of CANDU reactors. For the foreseeable future, bithermal water–hydrogen is expected

to remain only a supporting technology, likely to be confined to the intermediate stages of CIRCE plants.

3.5.3. Heavy water management

3.5.3.1. Introduction

HWRs are designed and operated with a view to managing their heavy water resource. The primary objectives of heavy water management are to:

- Ensure that an adequate supply of heavy water is available to operate and maintain the reactor,
- Minimize the capital and operating costs of the reactor,
- Maintain optimal heavy water chemistry.

These objectives are similar to the water management objectives of light water moderated reactors. The aspects that are unique to HWRs are discussed in the following sections.

3.5.3.2. Overview

Within a reactor, the heavy water management functions include receipt and storage of water, transfer of water between the reactor and storage systems, recovery of water escaping from the reactor, purification (upgrading) of water in order to remove any light water contaminants, and tracking of heavy water volumes as they move through the station. Figure 83 illustrates the heavy water network in a CANDU 6 station.

The above functions are accommodated by a variety of systems. Each system is designed and operated to achieve the primary goals listed above. In practice, these goals are applied as a series of design philosophies and operating principles:

- The heavy water inventory through the plant should be preserved by monitoring existing inventories, recovering losses and removing light water contaminants.
- Cross-contamination shall be avoided between:
 - Light water and heavy water,
 - Volumes of heavy water with different isotopic concentrations of D_2O ,
 - Clean and dirty D_2O ,
 - High and low tritium D_2O (for reactors that are both moderated and cooled with D_2O).

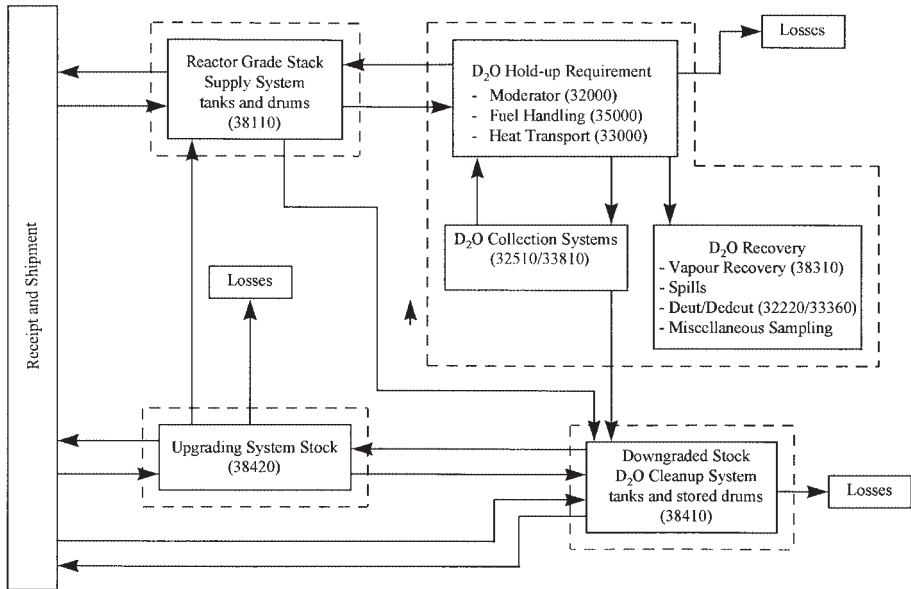

FIG. 83. D_2O network in a CANDU 6 station.

- Physical inventories shall be used to reconcile shipments, system inventories and losses.
- The escape of D_2O from the process systems shall be minimized, and that which does escape shall be recovered if economically feasible.

3.5.3.3. Heavy water supply

In addition to any water directly contained within the reactor and its process systems, HWRs must maintain operating and strategic reserves of heavy water. As with light water reactors, the primary reserves are stored in tanks that form part of the reactor auxiliary systems. Some stations maintain secondary reserves in additional tanks or in drums stored on the station site. Transfer systems are in place to move water between the various tanks and reactor systems.

Generally, HWRs are designed to receive their heavy water from off-site production and storage facilities. While on-site production of heavy water is feasible, various competitive production facilities exist throughout the world. Since little heavy water is lost from reactors through leakage, the dominant heavy water requirement is the initial reactor fill. Economics has therefore favoured this shipping based approach to supply. It is therefore likely that off-site production and shipping will remain the

standard approach. This approach is, however, site and production process specific, and the on-site production of make-up water may be favoured in the future.

Traditionally, heavy water has been shipped domestically and internationally in 200 L drums. This is convenient for a number of reasons: drum filling and drainage systems are both compact and economical. Stations have been, and are expected to continue to be, designed to accommodate this shipment method. Some utilities have adopted larger shipment containers, with appropriate transfer systems being incorporated in their stations. In some cases, this permits the strategic reserve of water maintained by each station to be decreased by sharing reserves across stations in the same geographic area.

Within a station, the dominant volume of heavy water is that contained in the reactor and its process systems. Only modest volumes of reserve water are needed. In the case of reactors that are both moderated and cooled by heavy water, then there are generally separate transfer and storage systems for these two types of water. This permits optimal water chemistry to be maintained in each system.

3.5.3.4. Recovering fugitive water

Heavy water can escape from the reactor through leakage or as a waste stream from purification processes (it can also leave the reactor through planned replacement operations, but these are not discussed here). In modern reactors, both escape pathways are minimized, thereby preserving the D₂O asset. In addition, systems are included to recover fugitive water automatically.

Great improvements have been made in reducing leakage rates through the adoption and development of advanced materials and components. In addition, modern plants have been simplified relative to older designs, minimizing the opportunities for component leakage while reducing maintenance requirements. Environmental qualification programmes build on this philosophy, and life-cycle management programmes will help maintain low leakage rates. Future reactors will see further reductions in leakage rates through continued system simplification and the use of improved materials and components. Considerable operating experience has been gained with these reactors, and this will continue to be fed back into operations and design. Ultimately, this benefits both routine and off-normal operations.

Modern reactors augment their leakage reduction efforts with systems that automatically recover water that escapes from the reactor. This water may escape in pure form, for example, water that leaks past the primary packing on packed valves, or in diluted form, for example, water that escapes as steam. Collection systems that capture pure water and return it to the reactor systems are highly effective and are included in most designs. These will continue to evolve, targeting smaller leakage pathways as it becomes economically viable to do so. Deuterium oxide leaked as

steam is recovered through desiccant dehumidifiers, with modern designs relying on molecular sieve desiccants. These are highly effective at recovering both D_2O and H_2O vapours. Enhancements to these systems include more economical dehumidifiers, increased dehumidification capacity and reduced H_2O collection through improved ventilation management.

In addition to recovering leaked water, modern reactors recover water generated through purification processes. Ion exchange resins are typically used for chemistry control. During operation, these become deuterated, and systems are included for the recovery of this heavy water. Typically, this recovery is achieved by displacing the retained heavy water with light water, a process that leaves a small quantity of D_2O on the spent resin. While the losses involved are very small, further reductions are anticipated. Future reactors will incorporate updated purification systems and deuterium recovery processes, reflecting both the feedback of operating experience into the design and the development of improved technologies.

3.5.3.5. *Upgrading water*

Upgrading is the process of removing light water from a stream of heavy water, thus increasing the isotopic purity of the heavy water. Upgrading is performed as part of the heavy water recovery process or as part of reactor physics management.

Recovered heavy water may contain significant quantities of light water, depending on the source of recovery. Typically, stations are provided with upgraders capable of restoring this water to reactor grade isotopic purity. For each station, there is a minimum isotopic purity below which it is not considered economically attractive to upgrade the water. Any water collected that is below this minimum is generally discarded. The minimum varies from station to station and is a function of the volume of water collected, the target isotopic purity in the reactor, the cost of replacement heavy water, the type and capacity of the upgrader, and various operating considerations. As reactor designs have evolved, the minimum isotopic purity has decreased. It is expected that this trend will continue.

Both LWRs and HWRs strive to maintain optimal water chemistry for materials performance purposes. In addition, heavy water reactors control their isotopic purity to achieve optimal reactor physics performance. Increasing the isotopic purity of the heavy water, for example, improves fuel economy and reduces waste generation. This increase can be achieved by minimizing the ingress of light water into the heavy water systems and by maximizing the purity of recovered water before it is returned to the reactor. The direct upgrading of reactor water can also be used, and the upgraders supplied with operating stations also serve this function. In modern reactors, however, the rates of light water ingress into the moderator are very low. Typically, direct upgrading is therefore only occasionally performed. Developments in this area have

focused on further reducing light water ingress and more closely modelling the reactor physics involved.

Both electrolysis and water distillation have been used for upgrading, with water distillation being the dominant technology employed in most stations. This process involves the separation of light water and heavy water under vacuum in a distillation column. Two products are produced: high grade D_2O and a waste stream containing traces of D_2O . The split between these two streams is both a design and an operating decision. As station designs have evolved, the purity of the high grade product has increased and the trace level of D_2O in the waste stream decreased. Alternative technologies are now available that further reduce this, making it feasible to build an upgrader that produces a waste stream containing less D_2O than is naturally present in fresh water.

3.5.3.6. Heavy water tracking

Heavy water is a valuable asset and needs to be tracked through a station as part of heavy water management. Heavy water tracking includes the monitoring of isotopic purity in various processes and storage locations, the monitoring of heavy water loss rates via important pathways, the maintenance of accounting records and the reconciliation of records with physical inventories. Historically, many of these tasks were performed through a combination of grab sampling and manual manipulation. This is an area where significant advances have been made possible through the application of modern instrumentation and computer technology. Advanced instrumentation greatly improves the accuracy and feasibility of on-line measurements, reducing the costs associated with heavy water tracking. Advances in computer technology greatly simplify the process of heavy water tracking. Taken together, it is now possible for stations to take physical inventories in minutes. As an added benefit, these technologies have decreased the time required to identify off-normal loss rates, ultimately reducing losses through timely maintenance.

3.5.4. Tritium management

3.5.4.1. Introduction

HWRs produce tritium through the capture of neutrons by deuterium nuclei. Exposing heavy water to a neutron field therefore results in the production of some tritium. A small amount of tritium may also be formed by the irradiation of light elements (boron, lithium) added to control water chemistry. The production rate depends on the volume of water irradiated and the strength and nature of the neutron field. Since the half-life of tritium is approximately 12.3 years, the tritium concentration builds up to an equilibrium value in a first order fashion.

Unless measures are taken to remove the tritium, concentrations reach approximately 90% of their equilibrium values after 40 years of operation. HWRs must be designed and operated so as to manage the occupational and environmental hazards associated with this tritium. Since this tritium is chemically bound to heavy water, tritium management is often viewed as an extension of heavy water management.

Of the low, medium and high level radiological hazards, tritium is classified as low. As a low energy beta emitter, tritium presents a negligible external radiation risk. The main health risk to humans and other life forms arises when tritium is ingested. In order to create an occupational or environmental radiation field, heavy water must therefore escape from the reactor systems. Tritium control therefore focuses on four tools:

- Minimization of heavy water escape,
- Isolation of areas with a higher risk of heavy water escape from those areas with a lower risk,
- Removal of escaped heavy water by recovery or discharge,
- Protection of workers and the environment with appropriate coverings and instrumentation.

In addition, some operators remove tritium from the heavy water using a detritiation process.

Although tritium is not a particularly toxic radionuclide, many engineering features are included in HWRs to mitigate the effects of a potential release from the reactor systems. Consequently, despite the increasing levels of tritium resulting from continued operation, contributions to worker dose and environmental emissions remain well within regulatory limits. Beyond this, these doses are very small relative to natural background, even at the oldest plants. It is expected that the trend towards lower occupational and environmental doses will continue, with new reactors outperforming older designs throughout their operating life.

3.5.4.2. Minimizing escape

Minimizing the escape of heavy water for tritium control is an extension of minimizing its escape for heavy water management. Modern HWRs minimize escape through the use of high integrity systems having a minimum of components, near all-welded construction of process piping, and the use of bellows seal or live loaded valves. For reactors that have the hot coolant thermally and physically isolated from the moderator, segregation of these two systems also helps minimize tritium escape. Typically, the tritium concentration in the moderator is higher than that of the coolant, although the coolant systems are more prone to leakage owing to their higher

operating temperature and pressure. Segregation of these systems therefore helps minimize escape. It is expected that future reactors will continue the trend of improved tritium control through reduced escape rates.

3.5.4.3. Isolating areas

Zoning is used in virtually all reactor types to minimize the spread of potential contamination. HWRs augment this system, segregating systems and components that present a higher risk of heavy water leakage from those with a lower risk. This segregation is implemented through equipment layout, physical barriers and ventilation control. Isolation has proven to be a very effective tritium management tool, and complements the segregation used to reduce the mixing of light water with recovered heavy water. With the adoption of computer based design tools and updated construction methods, future plants should achieve further improvements in tritium control through isolation.

3.5.4.4. Removing fugitive heavy water

Tritiated heavy water that has escaped from the reactor systems presents potential occupational and environmental hazards. Both hazards can be removed by recovering the heavy water using one of the heavy water management systems. The occupational hazard can also be reduced by discharging the fugitive heavy water from the plant.

The primary tools used in a modern plant for removing fugitive heavy water are the heavy water recovery systems. Key amongst these are the desiccant dehumidifiers used to recover heavy water from air. Tritium control considerations favour the use of dehumidifiers with very high removal efficiencies, leading modern designs to rely on molecular sieve adsorbents. Advances in technology now permit of smaller, more compact dehumidifiers, leading to higher total airflows through the dehumidifiers.

In addition to the dehumidifiers, almost every system used for heavy water recovery also serves a tritium recovery function. Thus, advances that reduce heavy water escape or improve heavy water recovery also advance tritium control.

3.5.4.5. Occupational and environmental protection

Typically, with modern HWRs, occupational doses are dominated by external doses, not tritium doses. The radiological health effects of tritium are well understood, and tritium monitoring and dosimetry are well-established technologies. HWR management therefore includes augmented health physics programmes that include tritium dosimetry. Occupational doses are generally

tracked through bioassays, and various portable and fixed instruments are used to monitor tritium fields inside the plant and emissions from the plant. In addition, highly effective protective clothing has been developed. Development work in this area has focused on improving the convenience of this protective clothing and simplifying dose assessments.

3.5.4.6. *Detritiation*

Tritium can be extracted from heavy water using a number of technologies, producing a tritium reduced D₂O product and a tritium enriched hydrogen stream. While the correlation between tritium concentrations and either tritium emissions or occupational doses is weak, tritium extraction (detritiation) does offer the capability of capping tritium concentrations at levels below the ultimate, equilibrium concentrations. It can also offer heavy water management advantages, as it simplifies the movement of heavy water between reactors or systems having different tritium concentrations. Detritiation also simplifies the decommissioning of a reactor, as it may improve the economic value of the D₂O asset. Developments in this area have focused on reducing the costs of detritiation technology and establishing the optimal time at which to introduce detritiation into the reactor life-cycle. It is expected that future reactors will continue to be designed to operate for their entire design lifetimes without implementing detritiation. With regard to existing and future reactors, consideration should be given to providing options for the employment of detritiation relatively early in their life as part of their heavy water and tritium management programmes.

4. ECONOMICS OF HWRs

4.1. INTRODUCTION

Economic studies of HWR operation have repeatedly shown that HWRs are a competitive source of base load electricity. Continuing efforts on cost reduction are important to maintaining the competitive edge of the HWR over other sources of electricity generation.

Determining the economics of a power plant requires an assessment of its costs (capital and lifetime expenditure) and its lifetime power generation. A nuclear power plant is a capital intensive project. In general, more than 60% of the costs are capital related. The amount of principal repayment and interest on capital has a great impact on the economics of a plant. Labour cost is another important factor influencing the

economics of a power plant and varies considerably from country to country and from location to location within a country. The economics of a power plant are very project specific and, therefore, care must be taken in each assessment.

The levelized unit energy cost (LUEC) methodology has been the most frequently used technique in assessing the economics of a power plant. Agencies such as the OECD Nuclear Energy Agency (NEA), the IAEA, the International Energy Agency and the International Union of Producers and Distributors of Electrical Energy have adopted this method in their evaluation of power plant economics.

The levelized cost methodology calculates the LUEC by discounting the time series of expenditures and income to their present values in a specified base year [58]. The date selected as the base year for discounting purposes does not affect the levelized cost. The equation relating the various parameters is:

$$\text{LUEC} = \frac{\sum_t \left[(I_t + M_t + F_t)(1+r)^{-t} \right]}{\sum_t \left[E_t (1+r)^{-t} \right]}$$

where: LUEC is the (average lifetime) levelized unit energy cost per kW·h of generated electricity
 I_t are the capital expenditures in year t
 M_t are the operation and maintenance (O&M) expenditures in year t
 F_t are the fuel expenditures in year t
 E_t is the electricity generation in year t
 r is the discount rate
 \sum_t is the summation over the period, including construction and operation during the economic lifetime and decommissioning of the plant as applicable.

The capital expenditures include the engineering design, supply and installation of nuclear and conventional equipment and materials, design and construction of architectural and civil structures, initial fuel load and initial heavy water inventory. The initial heavy water can also be leased, in which case it would become a part of the annual O&M cost. Interest paid during construction (IDC), major equipment replacements during the lifetime of the plant and the final decommissioning of the plant are also part of the capital expenditures. The decommissioning cost is provided by an annual provision collected over the lifespan of the plant.

The annual O&M expenditures include labour, consumable materials, heavy water upkeep (and lease payment, if leased), purchased services, etc. The fuel expenditures include the cost of new fuel and the storage and disposal of the spent fuel.

4.2. ECONOMICS OF HWRs

The majority of HWRs now in operation are of CANDU design and this design is therefore used as the basis for the discussion on costs. Since the first commercial operation of the CANDU HWR in the early 1970s, advances in technology have led to continually improved design and construction, and continued cost competitiveness. In addition to the CANDU 6 (700 MW(e) class), the product line has been expanded to include a larger CANDU 9 (900 MW(e) class) reactor which will benefit from the economies of scale, optimized site utilization and improved performance to achieve reduction in cost.

The economics of the CANDU HWR have been addressed in a recently published study [58]. The publication is an update and the fifth in a series of comparative studies of the projected cost of base load electricity generation, using the LUEC methodology. The common assumptions used in the study's economic analysis are as follows:

- A common economic lifetime of 40 years was assumed.
- A 75% load factor was assumed (the CANDU HWR load factor is in the range of 85%).
- Costs related to capital investment include overnight cost, IDC, and major refurbishment and decommissioning costs.
- Fuel costs include all costs related to fuel supply and final disposal of spent fuel. Assuming a secure supply, the cost of uranium is expected to remain stable well into the this century. The HWR has the lowest fuel costs because of its high neutron economy, which allows utilization of natural uranium and low enriched uranium.
- The O&M costs include all utility costs associated with the operation and maintenance of the unit that fall outside investment and fuelling costs (if heavy water is leased, the lease cost will be included here).
- Two discount rates were assumed: 5% and 10%. In general, the discount factor is higher in a developing country owing to the higher inherent risk of money lending in that country.
- The values are quoted in US dollars as of July 1996.

The LUECs of a 700 MW(e) class reactor and a 900 MW(e) class reactor in Canada, and a 700 MW(e) class CANDU 6 under construction in China at 5% discount rate are shown in TableVI, on a two unit basis [58].

4.3. FACTORS INFLUENCING CAPITAL COSTS

Of the three major components of generation cost — capital, O&M and fuel — the capital cost component comprises more than 60% of the total cost, followed by

TABLE VI. SELECTED LUECs AT 5% DISCOUNT RATE

Parameter	Country		
	Canada		China
	700 MW(e)	900 MW(e)	700 MW(e)
Net capacity (MW(e))	2 × 665	2 × 881	2 × 685
LUEC (US \$ million/kW·h)	29.57	24.67	26.69

O&M and fuel, respectively [58]. Capital cost reductions in engineering, design and construction are important for all reactor types to enable them to remain competitive with other sources of electricity generation. The major factors contributing to capital cost reductions are:

- Increased plant size of a reference design,
- Standardization and multiple units,
- Construction methods,
- Reduced project and construction schedules,
- Design improvement and simplification,
- Plant life management.

4.3.1. Increased plant size

Plant size affects the specific overnight capital cost (\$/kW(e)). A larger nuclear plant will have a lower specific overnight capital cost than a smaller one of the same design (economy of size). The following scaling function can be used to illustrate the effect of changing from a unit size of P_o to P [59].

$$\text{Cost}(P) = \text{Cost}(P_o) (P/P_o)^n$$

The scaling factor, n , varies around 0.6 for a single unit, or if the specific cost is considered ($C_s = \text{Cost}/\text{kW}(e)$), then $C_s(P) = C_s(P_o) (P/P_o)^{n-1}$.

4.3.2. Standardization and multiple units

Use of advanced engineering tools, such as the 3-D computer aided design and drafting system (3-D CADDs), enables a standardized CANDU plant to be designed with data access gained through a common project database. Standardization leads to efficiencies in engineering, construction and schedule. Standardized component designs contribute to the reduction in design, procurement and quality assurance costs.

Construction of multiple plant units on the same site will provide opportunities for further capital cost reduction in the following areas [59]:

- Siting: planning inquiries, site specific studies, public acceptance, etc.
- Land preparation for the transmission system.
- Licensing of identical units.
- Site labour.
- Common facilities: administration and maintenance buildings, warehouses, roads and guard stations, etc.

The reduction is achieved through the sharing of costs and through improved efficiency gained from the 'learning curve'.

An example of standardization and a multiple unit CANDU project is the Wolsong four unit station in the Republic of Korea. Cost reduction for all CANDU projects will continue to rely on standardization and multiple unit construction. There is a preference to sell CANDU reactors as twin units in order to maximize the benefit.

4.3.3. Construction methods

The ease, efficiency and cost effectiveness of constructing a nuclear power plant are key factors in improving quality and reducing the construction period and costs. Several advanced construction methods have been developed [60, 61]. As listed below, each method has its own merits, but overall, they actually enhance each other. Together, they offer the greatest potential in schedule and cost reduction. The methods comprise:

- Open top construction,
- Modularization (pre-fabrication),
- Parallel construction.

Open top construction allows direct installation of most material and equipment into the reactor building utilizing external cranes prior to installation of the dome. For example, a steam generator can be installed in one to two days through the open top rather than in the two weeks needed with temporary construction openings.

Modularization divides the work into packages. The packages take many forms, from civil structures to mechanical/electrical skid mounted packages. Packages can be prepared off-site to reduce congestion at the site and brought to the site when they are ready to be installed. When the open top construction method is employed, the package size can be very large.

In parallel construction, the sequence of events for reactor building construction is done in parallel rather than in series. This allows the mechanical construction programme to be integrated into concurrent work areas along with the civil programme.

4.3.4. Reduced project and construction schedules

The project schedule is ‘construction driven’. With the aid of 3-D CADD computer modelling, multiple construction scenarios for the project are evaluated for conflicts and risks, and optimized for schedule. Since a nuclear reactor power project is capital intensive, any reduction in schedule will manifest itself in interest savings, escalation and wage reduction, and lower overall project risk.

Detailed planning is of paramount importance in order to ensure ‘smooth’ logistics. Advanced planning software (e.g. PRIMAVERA) is used to formulate a detailed pre-construction schedule and, subsequently, a detailed construction schedule. The pre-construction schedule covers site preparation and procurement planning. The construction schedule is formulated in parallel with the construction sequences such that all critical path activities and material requirements are identified. A standardized plant will save on schedule time because much of the engineering and licensing can be completed before construction begins. Effective project management is essential for achieving project objectives in terms of quality, cost and schedule.

Continual optimization of the construction schedule and methods has produced remarkable results in shortening the total project schedule. Table VII shows the project durations of two of the more recent CANDU 6 plants.

4.3.5. Design to improve plant layout and economics

Design improvement and simplification aim to achieve less complex systems at reduced cost and improve reactor performance without compromising operational efficiency or nuclear safety. Many different areas of the CANDU design have been improved or simplified. Examples are:

TABLE VII. PROJECT DURATIONS OF TWO CANDU 6 PLANTS

Plant	Total project schedule (contract effective date to commercial operation) (months)
Qinshan Phase III Unit 1 (China)	72
Wolsong 2 (Republic of Korea)	77

- *Improved layout and site utilization.* The use of a ‘large, dry’ containment design (prestressed concrete building with a steel liner) gives lower design leakage and therefore greater margin in meeting the requirement of a reduced exclusion area boundary. The combination of a smaller exclusion area boundary and a more compact layout facilitate accommodation of a maximum number of units on any available site [60, 62].
- *Heavy water.* The development of a new heavy water production technology, CIRCE, will reduce the cost of heavy water.

4.3.6. Plant reliability

A plant life management programme has been developed in Canada to ensure that not only is the design life achieved or exceeded but that the plant runs reliably without forced outages for maintenance. A plant with high capacity factors and high operational performance will lower the unit cost of generating electricity. The programme begins at the design stage with the selection of materials, components and ageing provisions. During plant construction and commissioning, the baseline conditions for all critical components will be established, along with the required surveillance, inspection and maintenance programmes. Each component’s function is ensured by continual monitoring and planned regular maintenance.

4.4. FACTORS INFLUENCING O&M COSTS

In a nuclear power plant, the staff and related costs comprise the largest portion of the O&M costs. In a recent review on O&M costs performed by AECL, six areas of activity were identified as having the greatest potential for reducing staff and related costs:

- Condition based maintenance plus reliability centred maintenance,
- Information system integration,
- Capture in-service modifications,
- Automation of operator activities,
- Materials management,
- Integrated planning.

With the application of these activities, savings of 15% on the total current O&M costs can be expected for a new HWR project. Table VIII illustrates the potential reduction.

The benefits of incorporating the above recommendations are twofold. First, there is the potential to lower the cost, and second, the performance of the reactor can be improved with shorter scheduled maintenance and less forced outage.

TABLE VIII. POTENTIAL REDUCTION ATTAINABLE IN O&M COSTS FOR A NEW HWR PROJECT

Item	Current proportion of O&M costs (%)	Potential cost reduction (%)
Labour and benefits	57	15
Materials	13	10
Other	30	20

4.5. FACTORS INFLUENCING FUEL COSTS

The ability to burn natural uranium is a unique feature of HWRs. The benefits of high neutron economy, which allows use of natural uranium, include low fuelling costs compared with other nuclear power plants, no reliance on the supply of uranium enrichment or fuel reprocessing, and low uranium resource consumption. Fuel fabrication is a simple and inexpensive process. Overall, the HWR natural uranium fuel bundle is an easily manufactured product that client countries have found straightforward to localize.

A new fuel bundle carrier, the CANFLEX 43 element fuel bundle, can be fabricated at only slightly higher cost and will achieve a peak element rating 20% lower, and thermal margins 6–8% higher, than normal. This can result in longer fuel channel life or increased power output.

The HWR has a very flexible fuel cycle; SEU can also be used. Enrichments between 0.9% and 1.2% would extend the burnups by a factor of two or more and reduce the fuel cycle cost by about 30%.

4.6. THE NEXT TWENTY YEARS

Further R&D efforts are planned in order to improve the design, project schedule and construction methods needed to achieve further cost reduction in HWRs. Examples of such enhancements and research activities are:

- Development of fuel channel and steam generator designs, and development of other critical components that will meet or exceed a lifetime capacity factor of 90%;
- Use of CIRCE to reduce the cost of heavy water by about 30%;
- Improvement in ‘constructability’ and, hence, schedule reductions;
- Employment of advanced HWR fuel cycles.

As a non-greenhouse gas emitting source of energy, and in the wake of the Kyoto Protocol, the HWR is well positioned to become a major electricity source in this millennium.