

Chapter 3

Magnetic Flux Leakage

3.1 Introduction

Source: Magnetic Field, may be produced by:

- Applying electric current through a conducting specimen.
- Introduction of field due to the proximity of some magnetizing field (permanent magnetic or electrical current through a conductor).

Current be DC, AC, or rectified.

Modification: Flaws in *ferromagnetic* materials affect distribution of magnetic field.

Detection: Magnetic flux sensitive sensors (coils, solid-state magnetic sensors), or magnetic particles.

Indication: Change magnetic flux distribution on surface.

Interpretation: Relate changes in magnetic flux distribution to defect.

3.1.1 Advantages

- Detects surface and subsurface flaws.
- Simple, no elaborate electronics.
- Low cost and rapid.

3.1.2 Disadvantages

- Works only with ferromagnetic materials.
- Not too sensitive to deep flaws.
- Demagnetization of specimen may be required after testing.
- Indication is obtained only when flaw is \perp direction of magnetic field, i.e. field orientation is important.
- Some operator experience is required to adequately administer the technique and interpret the results.

3.2 Magnetism

3.2.1 Basic Parameters

Magnetization is the result of motion of electrons:

- When an external magnetic field is applied, free electrons movement occurs resulting in a magnetic field.
- Bound electrons circulation in orbital motion around the nucleus result in the formation of dipoles and an internal magnetic field.
- Spin motion of nucleus, electrons and molecules also produce an internal magnetic field.

Magnetization moment, \vec{M} , of material can be defined as the dipole moment or the density of individual dipoles in the material (a dipole is equal to the pole strength \times the distance between poles).

Flux density, \vec{B} , is equal to the magnetic force divided by the pole strength and is expressed in units of Newtons/amp m, Tesla, or Weber/m² (all are equivalent units).

Field intensity, \vec{H} , is expressed in amp/m.

$$\vec{B} = \mu \vec{H} = \mu_0 \mu_r \vec{H} \quad (3.1)$$

where μ is called the permeability, with units called henrys/m, μ_0 is the permeability of vacuum ($= 4\pi \times 10^{-7}$ H/m), and μ_r is the relative permeability (dimensionless). Note that a henry = (N/amp m)/(amp/m) = N/amp².

External field, \vec{H} , affects atomic magnetic field, to the extent of the magnetic susceptibility, χ_m of the material:

$$\vec{M} = \chi_m \vec{H} \quad (3.2)$$

χ_m can be defined as the magnetization, \vec{M} , per unit field intensity. Once can express \vec{B} as

$$\vec{B} = \mu_0(\vec{H} + \vec{M}) \quad (3.3)$$

that is the flux density is the result of the application of an external field, \vec{H} and the internal magnetism, \vec{M} . Leading to:

$$\mu_r = \mu/\mu_0 = 1 + \chi_m \quad (3.4)$$

Therefore a material with poor magnetic susceptibility, has a relative permeability close to one, \vec{M} close to zero, and therefore a small flux density is produced within.

3.2.2 Material Classification

Diamagnetics

- Diamagnetism is the field produced by the dipoles due to bound electrons.
- All materials have some magnetic characteristics because of these dipoles.
- χ_m due to diamagnetism is given by:

$$\chi_m = \frac{-\mu_0 N e^2}{6m_e} \sum r_i^2 \quad (3.5)$$

where N is the atomic density, e is the charge of an electron, m_e is the electron's mass and r_i is the radius of an electron orbit.

- χ_m is independent of temperature here. Why?
- Diamagnetism is prominent in materials with closed electronic shells, rare gases, C, Si, Ge etc.

Paramagnetics

- Paramagnetization occurs when the spin of nuclei, electrons, and molecules tend to align in the external magnetic field.
- χ_m due to Paramagnetization is always positive and is largest at low temperature, as temperature tends to randomize orientation.
- Transition metals, rare earth ions with incomplete inner shells, salts of transition elements, e.g. $\text{KCr}(\text{SO}_4) \cdot 12\text{H}_2\text{O}$, salts and oxides of rare earths are example of paramagnetic materials.

Ferromagnetic

- These are paramagnetic materials with large molecular fields.
- In these materials, a very high flux density is produced by a low external field.
- These materials exhibit hysteresis in B - H curve.
- Remanence value, B_r , is value of B at $H = 0$ in B - H curve.
- Coercivity value, H_c , is value of H at $B = 0$ in B - H curve.
- The parabolic increase of B with H is known as Rayleigh region. This is the region scanned by eddy current NDT applications when used in unmagnetized ferromagnetic materials.
- Change in B_r , H_c and the saturation flux are all indicators of changes in material, which could be due to defects, as they depend on chemical composition, residual stress, heat treatment, inclusion density.
- For these materials, M varies linearly with H up to a certain saturation value at which maximum magnetization is reached and M stays constant with increase in H .
- Examples of ferromagnetic materials are Fe, Co and Ni, and their alloys.
- Magnetic flux leakage NDT applies to ferromagnetic materials, such as low carbon steels which are used in many industries (automobile, construction, oil, etc.).

Antiferromagnetics

AT low temperature, the magnetic field in some paramagnetic materials causes spontaneous magnetization of two sublattices within the material, producing a net magnetic field that is very low.

Ferrimagnetics

Some materials show both saturation and hysteresis effects below a certain temperature, called the Curie temperature, but become paramagnetic above this temperature. Examples are cubic ferrites metal oxides and hexagonal ferrites. These materials are poor electrical conductors and good for use in pickup-coil cores as they tend to amplify magnetic field without inducing large eddy currents.

3.3 Modification

- Lines of flux are created in a direction $\perp \vec{H}$. In a permanent magnet, magnetic lines of flux flow from the north pole to the south pole of the magnet.
- Lines of flux are disrupted by discontinuities or breaks in a permanent magnet.
- Lines of flux follow or flow through magnetic materials.
- Discontinuities disturb the magnetic lines of flux so that the lines of flux leave (leak) the surface of the specimen.
- Leaked flux can be detected by a sensor by the magnetic particles it collects, to indicate the presence of a discontinuity.
- The discontinuity should be \perp lines of flux.
- Test needs to be repeated at least twice by changing the direction of \vec{H} by 90 degrees, unless the orientation of the discontinuity is known.
- Subsurface discontinuities also affect the distribution of flux lines at the surface, with their effect decreasing with depth.

3.4 Sources

3.4.1 Types

- Permanent Magnets are available as bar or horseshoe magnets, but are not widely used since they do not produce a strong magnetic field.
- Magnetic fields induced by electrical current are much stronger than those from permanent magnets.
- Alternating current (AC) maximizes magnetic flux at surface, voltage is easily stepped down, alternating direction of current makes the magnetic particles more mobile, increasing sensitivity, AC also facilitates demagnetization.
- Direct current (DC) provides deeper penetration of flux lines into the specimen, but it is cumbersome to use as the voltage cannot be changed without cumbersome and expensive motor-generator sets.
- Rectified current (RC) allows current flow in only one direction, half-wave rectifiers produce pulses of current, while full-wave rectifiers switches the -ve portion of the AC; RC gives penetration comparable to DC but AC power can be utilized and since magnetic particles can still be mobile sensitivity is also maintained.
- Right-hand rule to determine direction of magnetic field lines: if the thumb of the right hand points in the direction of the current, the fingers point in the direction of the magnetic field, and vice versa, i.e if the current is in the direction of the fingers, the magnetic flux will be in the direction of the thumb.

3.4.2 Field Lines

- Circular fields are produced by passing a current through wire.
- Longitudinal flux lines are produced by a current flowing through a wire that is wrapped around the specimen.
- Prod method: current enters and leaves specimen through two hand-held electrical contacts against the specimen.
- Yoke: a horseshoe magnet longitudinally magnetized produces flux lines in the specimen from one pole to the other.

- In Prod and Yoke method, inspection areas must overlap since adequate inspection cannot be made at the poles.

3.4.3 Required Current

ASME Boiler Code, Section V, Article 7, Magnetic Particle Inspection:

3.4.4 Circular Magnetization

Direct Contact Method: Magnetizing current flowing through specimen, direct or rectified current 700-800 amps per inch for part diameters up to 5 inches.

Prod Method: Maximum prod spacing of 8 inches, minimum 3 inches, Direct or rectified current minimum of 100 and maximum of 125 amps per inch of prod spacing, for sections less than 3/4 inches thick current shall be 90-110 amps per inch of prod spacing.

Yoke Method: AC such that yoke has a lifting power of at least 10 lb and a pole spacing of 3 to 6 inches. DC or permanent magnetic yokes require 40 lb lifting power and pole spacing of 3 to 3 inches.

Longitudinal Magnetization

Encircling Coil Method:

- For test parts with length/diameter (L/D) ratio ≥ 4 , direct or rectified current at $35,000 \text{ amps-turns}/(2+L/D)$, e.g. a part 10 inches long by 2 inches diameter has an L/D ratio of 5, therefore $35,000/(2+5)=5,000$ amps-turns is required, for a 5-turn coil, the current required is 1,000 amps.
- For parts with $4 < L/D \leq 4$, and for smaller parts magnetized in a larger fixed-size coil, direct or rectified current at $45,000 \text{ amps-turns}/(L/D)$.
- For parts with $L/D < 2$, alternating current shall be used.

In general AC current can be half the DC current required to produce acceptable indications at the surface.

3.4.5 Demagnetization

- Required if additional welding is to be done, or if magnetization affects use or function of test object.
- Accomplished by applying decreasing AC currents.

3.5 Detection

3.5.1 Magnetic Particles

Small pieces of soft iron ($1 - 600 \times 10^{-4}$ mm) are used in magnetic particle inspection (MPI), most common method, particles can be placed close to flaw, can be applied to irregularly shaped parts, lighting is used to better see the indication (change in flux lines distribution), Lighting: natural light, sodium lamps (yellow), ultraviolet on fluorescent particles.

Dry Method

Effective for subsurface flaws, more convenient for use, they are airborne until coming in contact with the metal surface, by blowing loosely held particles are swept away and the remaining particles cluster around flaws.

Wet Method

Particles poured or sprayed no surface remain in suspension until they are attracted by magnetic field gradient, as they are free to move they tend to gather about the fringing magnetic fields of surface flaws, and remain there while the liquid carries away excess particles.

3.5.2 Magnetic Rubber

An extension of MPI, magnetic particles are carried in a castable (at room temperature) matrix (liquid rubber) which holds the particle in a permanent record when the test is complete, the magnetic field causes the particles to migrate towards and concentrate at discontinuities, after 30 minutes or longer, the magnetic field is stopped and the rubber casting can be removed carrying with it a permanent record.

3.5.3 Pickup Coils

In travelling (moving) coil , in accordance to Faraday's law of induction:

$$V = -\frac{d\phi}{dt} = -B_{\perp}Lv \quad (3.6)$$

where V is the voltage between the coil ends, ϕ is the magnetic flux, B_{\perp} is component of the field that is \perp the direction of travel, L is the length of the wire and v is the speed of travel. This is an easy, cheap, but a velocity-dependant sensor.

3.5.4 Hall Elements

- This is a small special crystal (semiconductor) when excited by the passage of current act to the presence of an external magnetic field by developing a voltage, V_H , across two parallel faces:

$$V_H = \frac{R_H I_x B_z}{b} \quad (3.7)$$

where R_H is a constant, called Hall coefficient, b is crystal thickness and defines the z -direction , I_x is the current is the x direction, where $x \perp z$, and B_z is the flux density in the z direction.

- Most useful in laboratory experiments to detect both active and residual leakage fields.
- Its small size makes it attractive for detecting small flaws, but then arrays of them are required to cover a large area.
- No two elements have exactly the same sensitivity.

3.5.5 Magnetodiodes

A solid state device the resistance of which changes with applied field strength, is highly sensitive but is temperature dependant.

3.5.6 Magnetic Recording Tapes

Magnetic tapes are made from finely divided ferrite embedded in wear-resistance neoprene, particles become magnetized by flaw flux leakage.

3.5.7 Förster Microprobes

This is a ferrite core with one or more coils wrapped around it, needs frequency change to provide the travel component required in an ordinary coil, it produces a much stronger signal than a conventional Hall element.

3.6 Applications

3.6.1 Bars

Uniform bars and shafts, current passes length wise for longitudinal and tilted flaws, and a coil may be used for transverse and tilted flaws.

3.6.2 Tubing

A large central conductor is used for longitudinal flaws, and a coil is applied for transverse flaws.

3.6.3 Plates

Inspected in stages using prods, yokes are useful for surface flaws only, need to apply the field at two \perp directions, the dry method with AC or DC is suitable.

3.6.4 Weldments

Weldments are plate-like, prods with DC are first choice, current needs to be applied both along and across the weld, yoke method are used when electrical contacts cause burns, testing may be carried out with the coil method if oriented in suitable ways.

3.7 Work Problems

1. Describe how to detect transverse cracking in a seam weld?
2. Draw the magnetic field around a groove in a bar magnet.
3. What would be the approximate current requirements for circular magnetization of a cylindrical bar of metal 75 mm in diameter and 30 mm long? Specify the type of current you will use and explain why.

4. Repeat above question for longitudinal magnetization using a coil of 15 turns.
5. A 1000-turn coil of cross sectional area 0.5 mm^2 is placed on a horizontal bench top. If the earth's vertical field component is 24 amp/m, what is the vertical flux through the coil? The coil is turned over in 0.5 s, What is the flux change through the coil due to the earth's vertical field component? What is the voltage induced between the terminals of the coil?

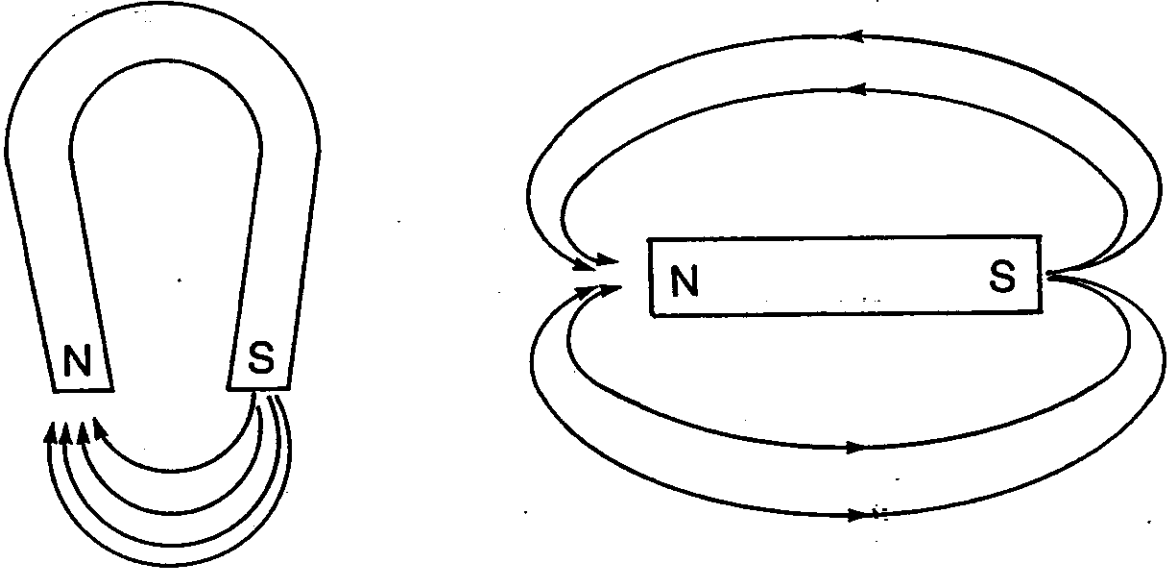

Figure 3.1: Magnetic Poles

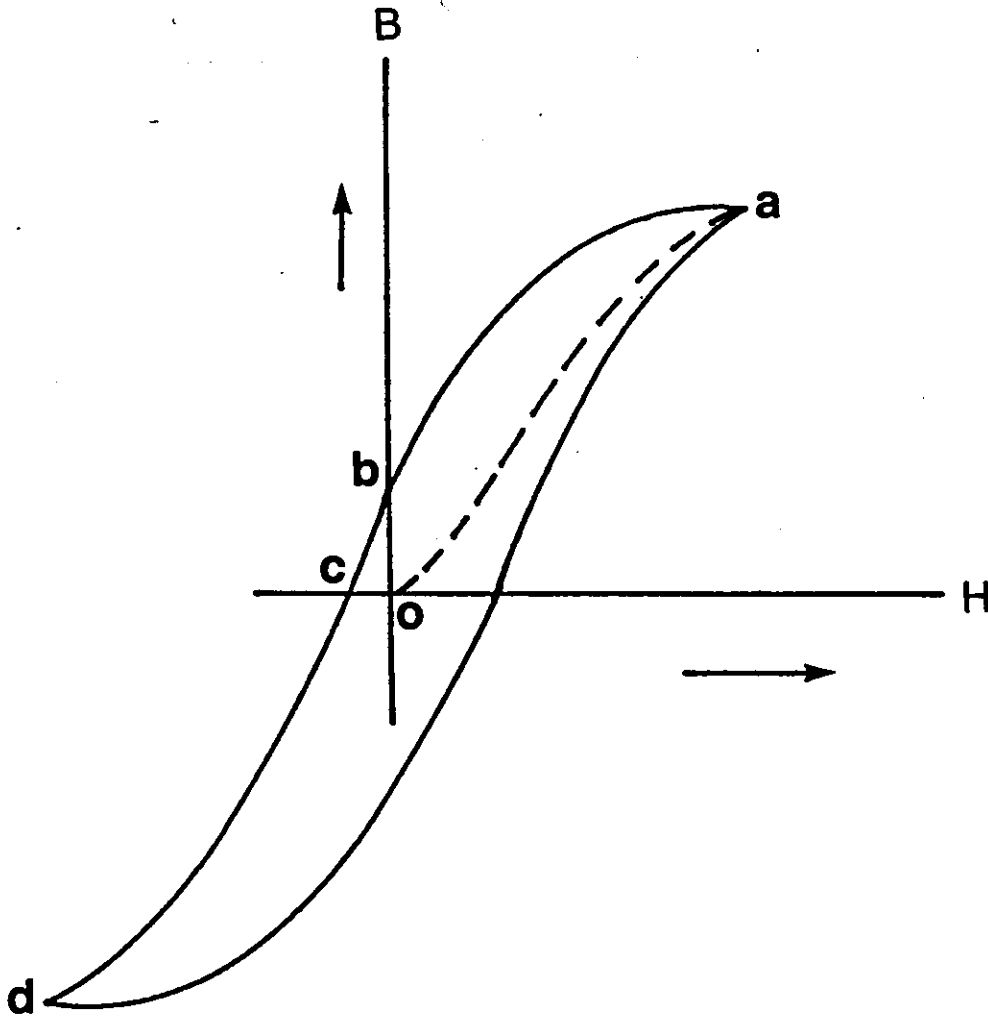

Figure 3.2: Hysteresis Curve

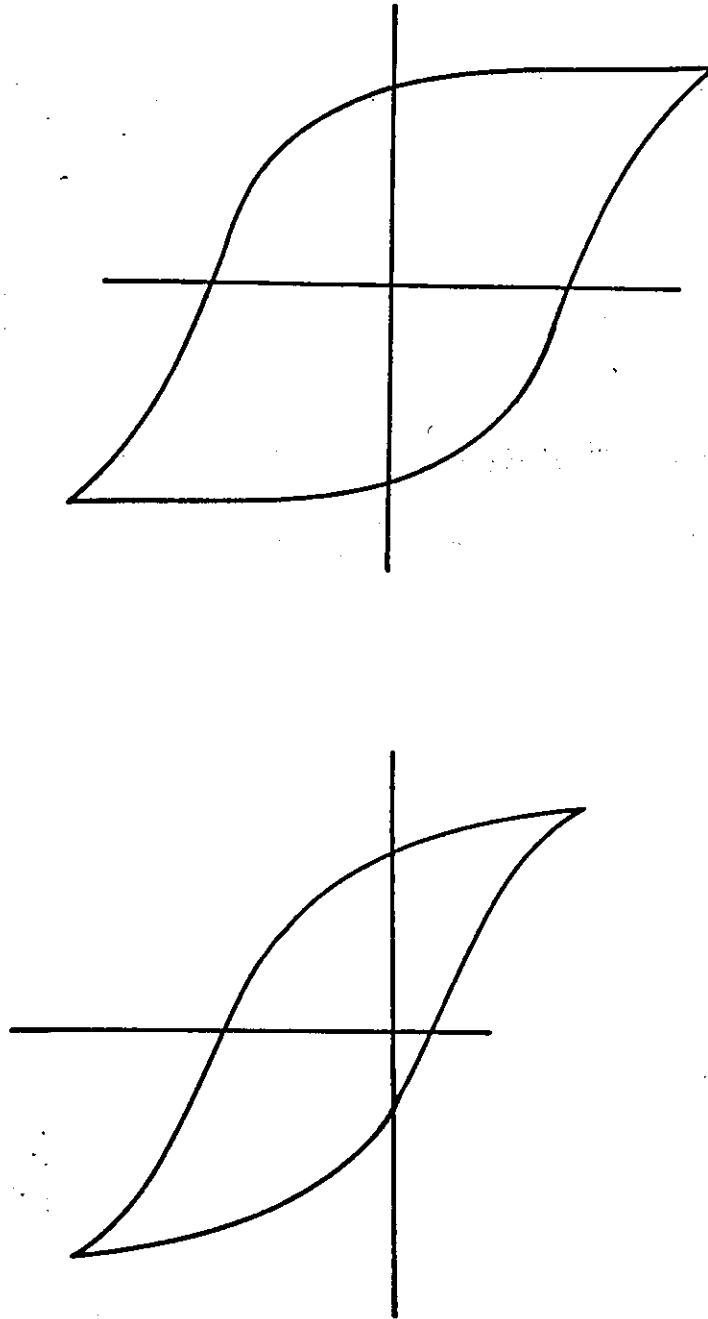

Figure 3.3: Hysteresis for High Retention (Top) and Poor Retention (Bottom) of Magnetic Fields

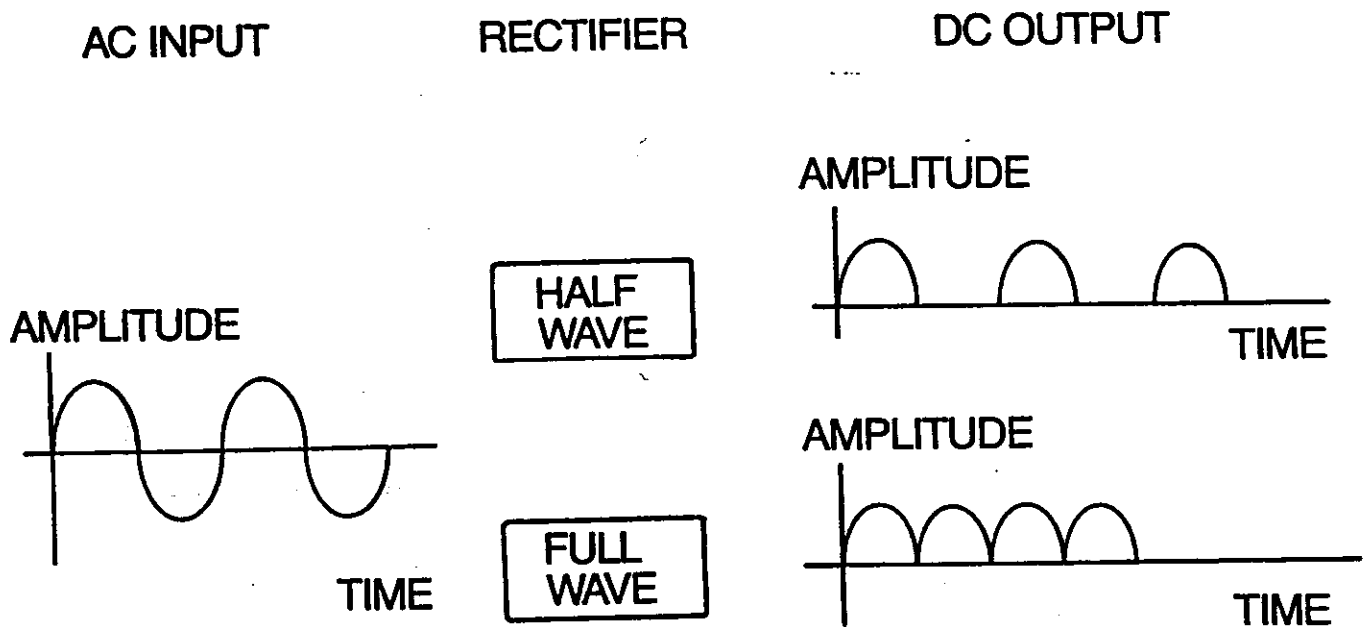

Figure 3.4: Rectified Current

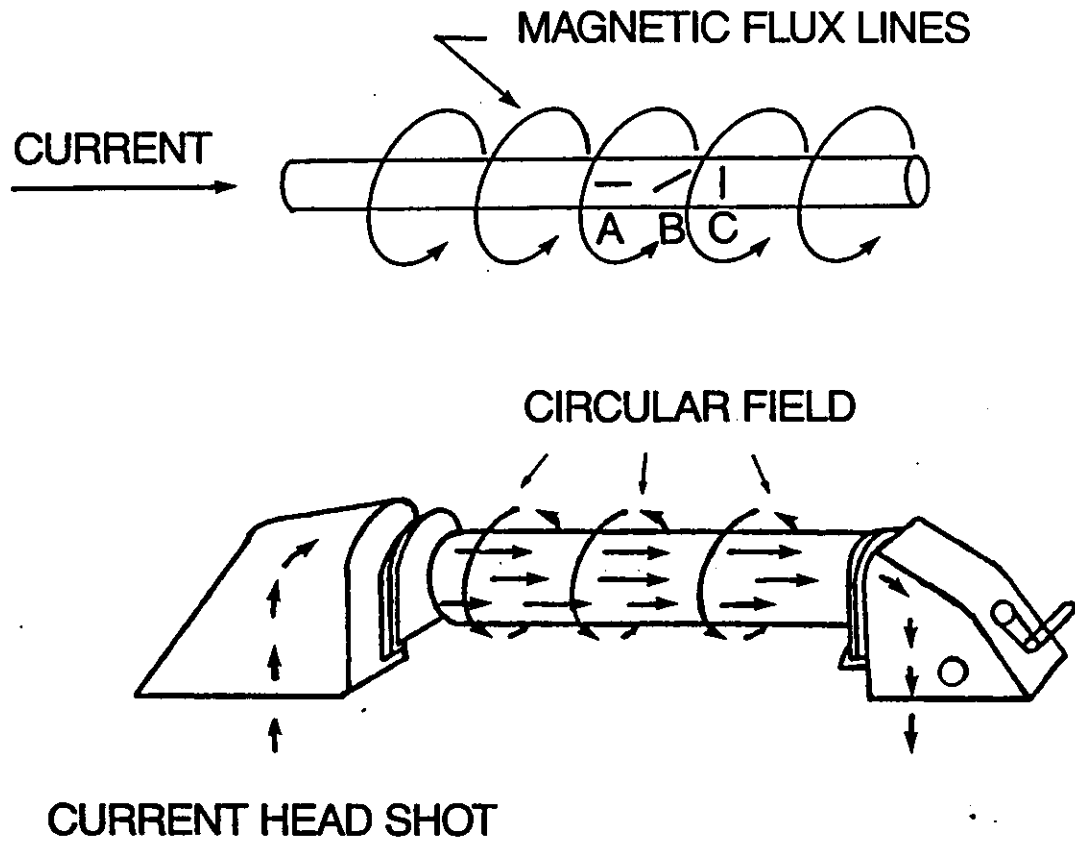
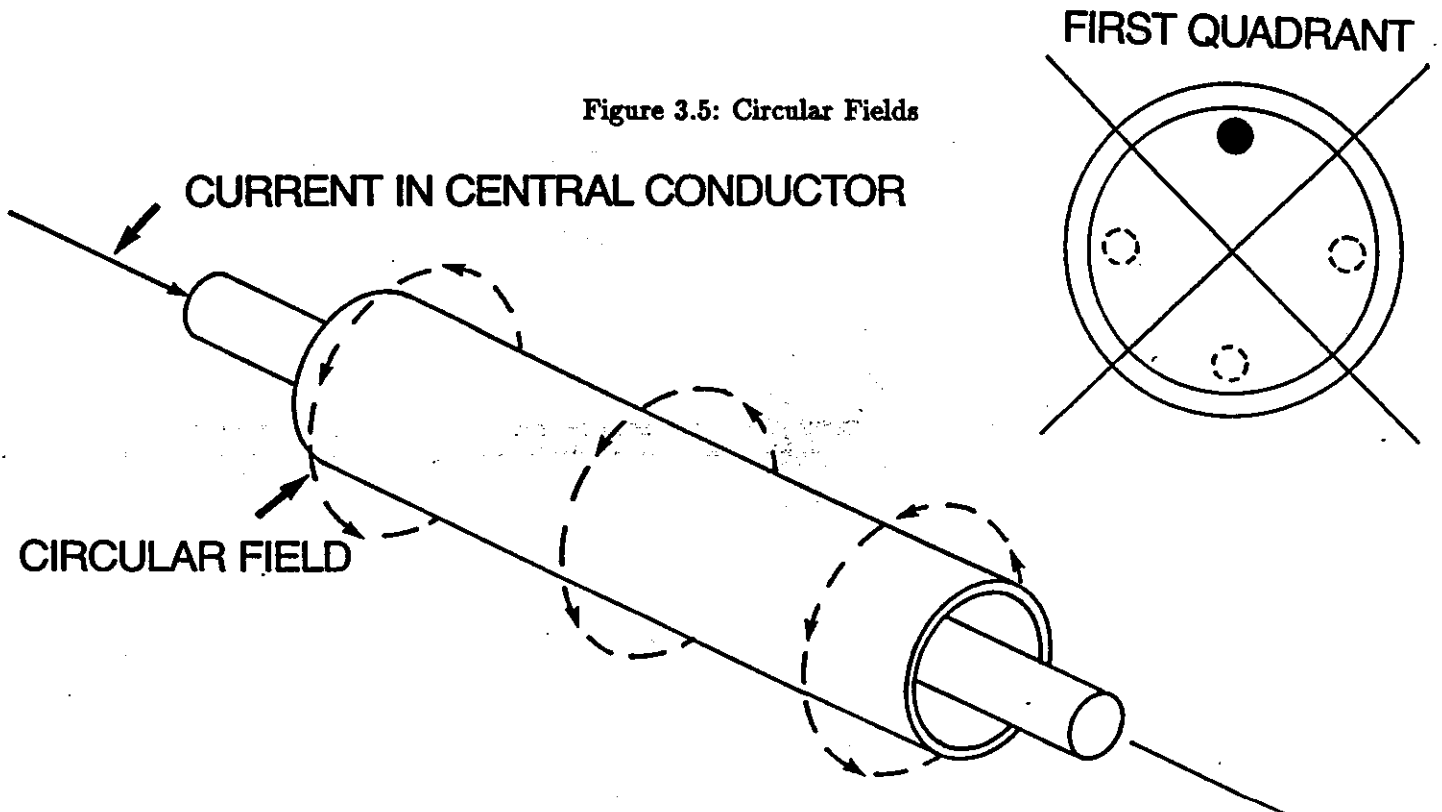

Figure 3.5: Circular Fields



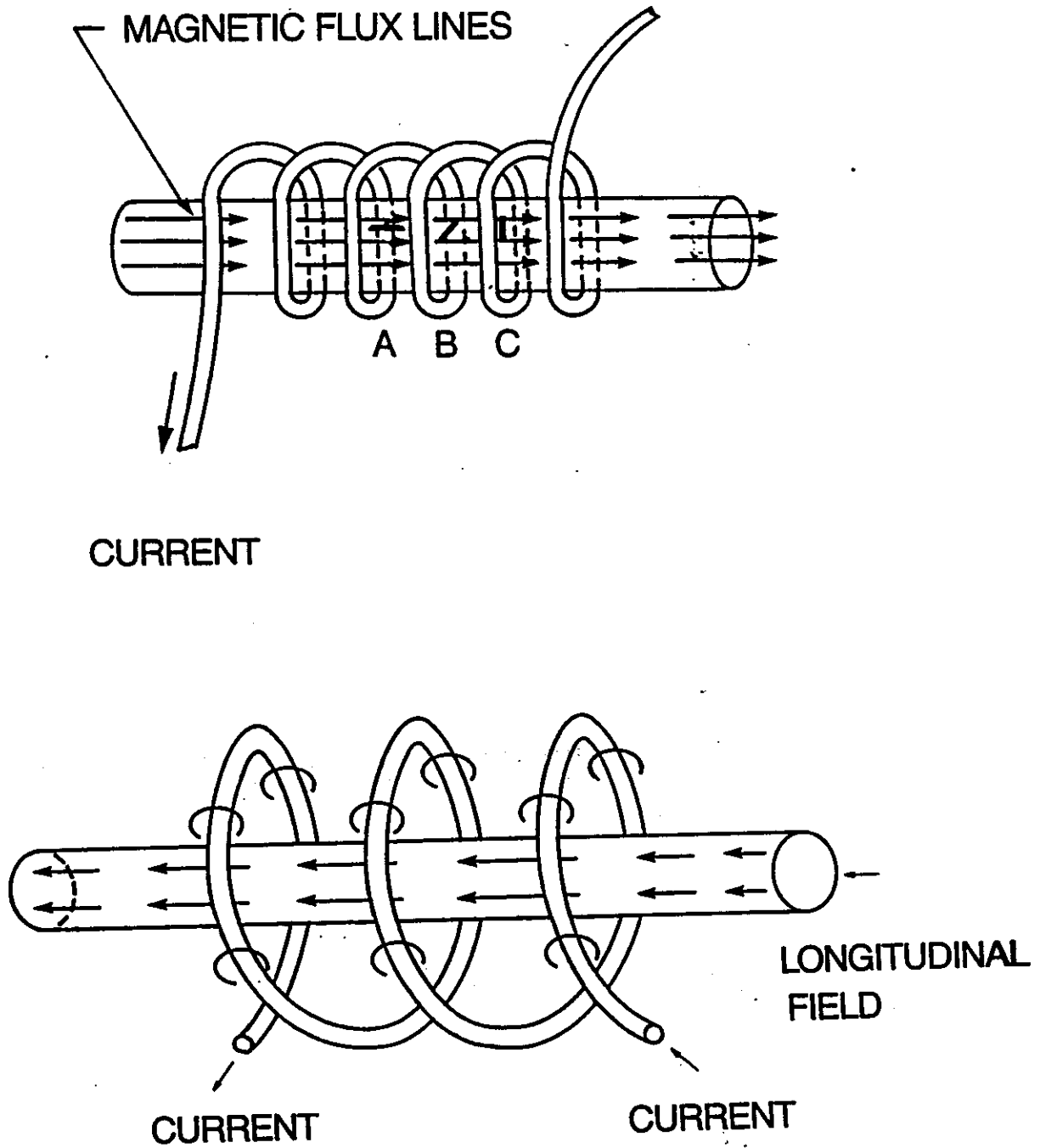

Figure 3.6: Longitudinal Fields

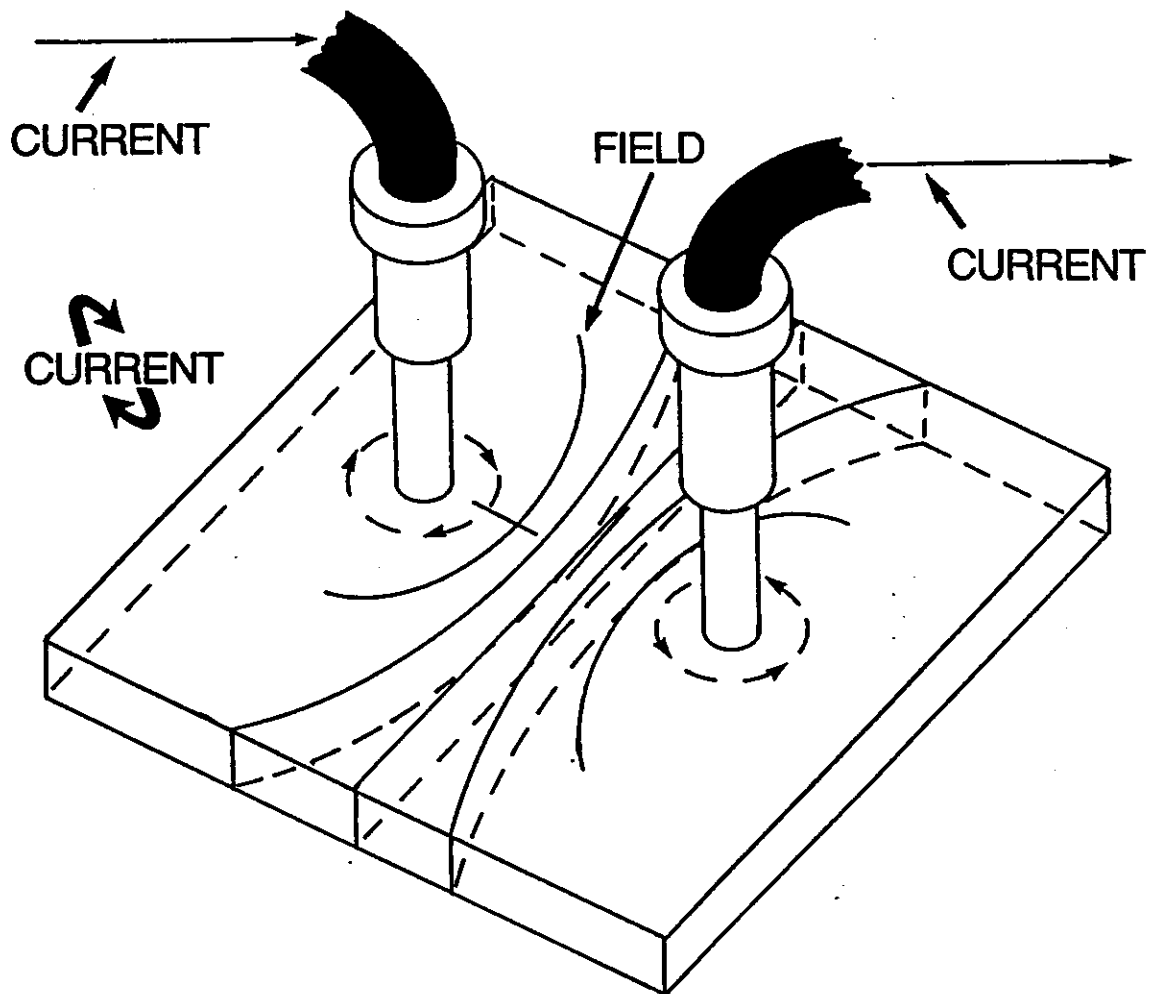

Figure 3.7: Prod Method

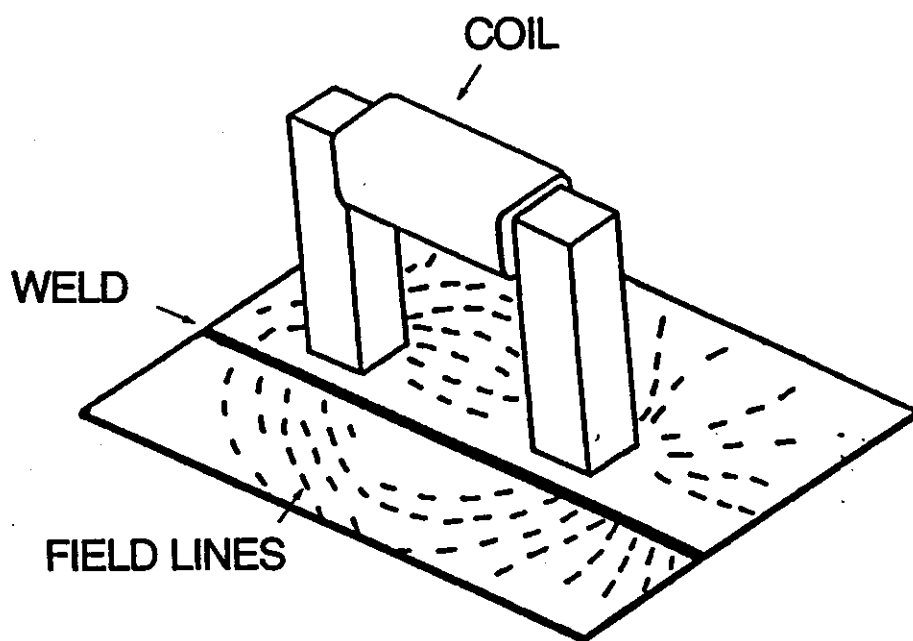

Figure 3.8: Yoke Method

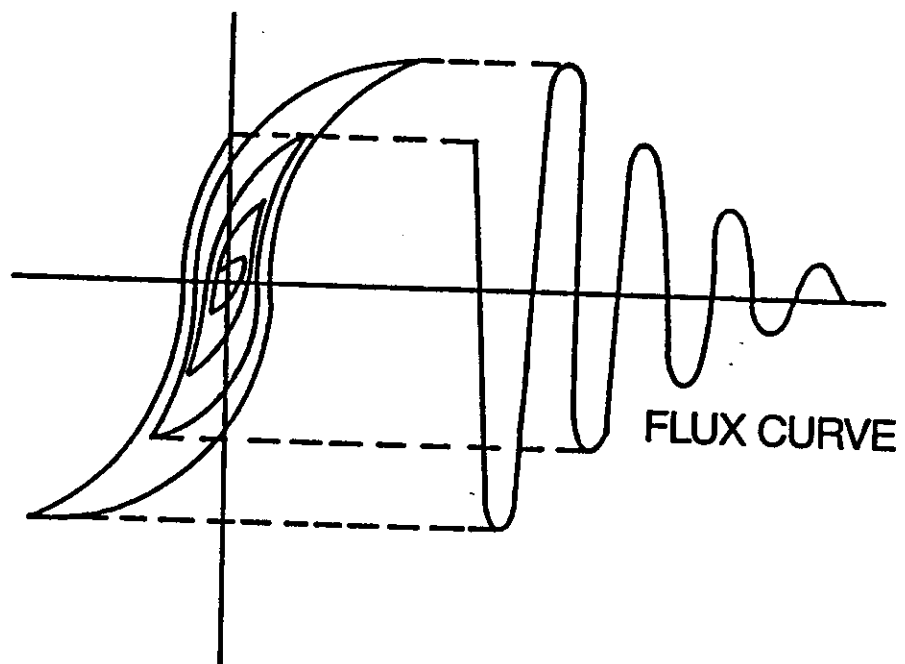

Figure 3.9: Demagnetization