

PI 30.21-1

Electrical Equipment - Course PI 30.2

CONDUCTORS

OBJECTIVES

On completion of this module, the student will be able to:

1. In one or two sentences:
 - a) Define the term "ACSR";
 - b) Explain the purpose of the steel core in ACSR cable.
2. Briefly, in writing or using a table or chart, list the considerations made in the selection of a conductor material for:
 - a) Generators and Transformers;
 - b) Transmission lines;
 - c) Grounding Conductor;
 - d) IPB;
 - e) Bus Bars.
3. Define, in one or two sentences, the following units used for conductor size:
 - a) Square Mil;
 - b) Circular Mil;
 - c) AWG.
4. Briefly, in writing, state the three methods which can be used to reduce conductor resistance.
5. In one or two sentences, state two electrical considerations that affect the conductor size.
6. Briefly, in writing, state and explain each of the general considerations given for the joining of aluminum cable.
7. Briefly explain what an Isolated Phase Bus is, what metal it is made from and how and why additional cooling is provided.
8.
 - a) Briefly explain what a Bus bar is and which metals are used for its construction;
 - b) List two types of indoor bus bars and two types of outdoor bus bars.
9. List, in writing, six factors which can damage a cable.

CONDUCTORS

1. Introduction

This lesson examines the;

- (a) Basic properties of the material used as conductors.
- (b) Units, types, and the applications of conductors.
- (c) Care of cables in the power plant.

2. Electrical Conductors

Electrical conductors are used to convey power from an electrical source (eg, a generator) to an electrical load (eg, a light bulb, heater, heat transport pump motor).

Conductors are made from metals which easily conduct electric current; that is, they have low resistance to electrical current flow. Low resistance of conductors is attributed to the fact that their atoms give up free electrons more readily. Copper and aluminum are frequently used as conductors. A comparison of these two conductors is shown in the table below.

	Copper	Aluminum	
Tensile strength for same conductivity (MPa)	150	80	Cu is stronger
Density kg/m ³	8930	2700	Cu is heavier
Cross-section relation for same conductivity and length (mm ²)	1	1.56	Cu is smaller
Specific Resistance (Ω-meter x 10 ⁻⁸)	1.7	2.65	Cu offers less resistance
Corrosion Resistance	Good	Poor	Al oxidizes instantly
Temperature Expansion Coefficient	17 x 10 ⁻⁶ m/°cm	24 x 10 ⁻⁶ m/°cm	Al expands more
Melting Point °C	1083°C	660°C	Cu can withstand higher temperatures
Cost	High	Lower	Cu is more expensive

Table 1

2.1 ACSR Cable

Aluminum Conductor with Steel Reinforcement (ACSR) is made of aluminum strands with a steel core in the centre. This steel core is used to compensate for the poor mechanical properties of aluminum. Figure 1, below, shows the construction of ACSR cables.

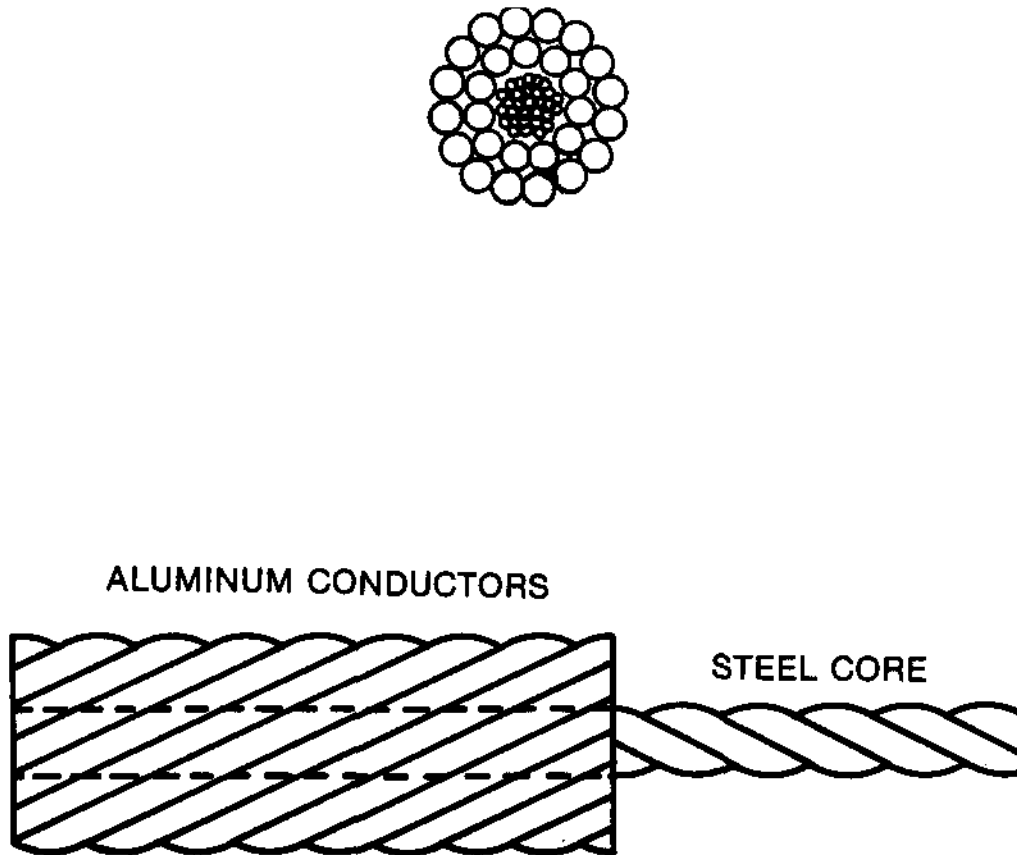

Figure 1: Aluminum Conductor with Steel Reinforcement (ACSR)

3. Selection of Conductor Material

The selection of a conductor material is made on the basis of the properties most desired for a given application. In large electrical generators and large transformers, factors of concern for conductors are:

- (a) Physical size.
- (b) Low winding resistance.
- (c) Ease of making connection.
- (d) Good mechanical strength.
- (e) Good corrosion resistance.
- (f) High melting point.
- (g) Cost.

Copper possesses all of the above properties except (g). Properties desired outweigh the cost. Hence, copper is used in large generators and transformers. Cost of these units in Ontario Hydro plants can be over a million dollars each.

In transmission lines, it is desired to have:

- (a) Low cost.
- (b) Good mechanical strength.
- (c) Light weight.
- (d) Low resistance.

Aluminum comes closest to providing most of these requirements. Low cost and the distances involved in transmission lines justify the use of aluminum. In practice, aluminum conductors with steel reinforcement are used for improved strength.

Grounding

Only copper is permitted, due to its low electrical resistance and good corrosion resistance properties.

Isolated Phase Bus (IPB)

Aluminum is used, due to cost considerations. IPB will be discussed in Section 9.1.

Bus Bars

Copper, aluminum, or ACSR conductors can be used depending on the cost and the mechanical strength required.

4. Units of Area of Cross-Section

4.1 SQUARE MIL

ONE MIL = 0.001 inch or 1×10^{-3} inch.

SQUARE MIL is the unit of cross-sectional area used for square conductors. A square mil is the area of a square; the sides of which are 1 mil in length. This is shown in Figure 2A, below.

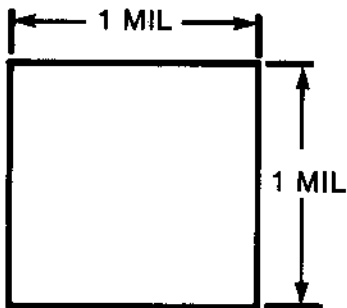

(A) Square MIL

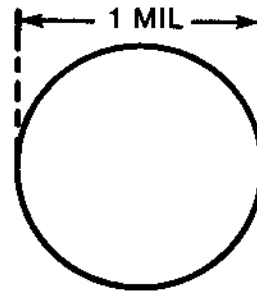

(B) Circular MIL

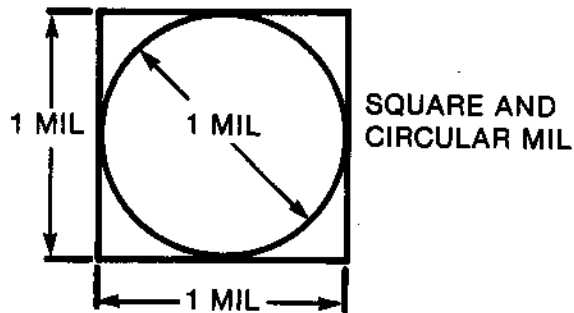

(C) Comparison of CIRCULAR MIL to SQUARE MIL

Figure 2: Square MIL and Circular MIL

4.2 Circular Mil

The CIRCULAR MIL is the standard unit for wire cross-sectional area which is used in American wire tables. A circular mil is the area of a circle having a diameter of 1 mil. The area of cross-section (in circular mil units) for a circular conductor is obtained by squaring the diameter of the conductor, which is expressed in mils. See Figure 2(B).

By definition:

$$\text{AREA(in circular MILS)} = (\text{diameter in MILS})^2$$

A comparison of Circular MILS to Square MILS is shown in Figure 2(C)

In large sizes, wires are stranded to increase the flexibility of the cable. The strands are single wires twisted together, in sufficient number to give the required cross-sectional area of the cable. The total area in circular mils is obtained by multiplying the circular mils of one strand by the number of strands in the cable.

4.3 American Wire Gauge (AWG)

AWG is the method of wire sizing used in North America. AWG is also known as Brown Sharpe Gage (B & SG). Wires are manufactured under this sizing system in North America. As apparent from Table 2, the wire diameter becomes smaller as the gage number becomes larger.

A wire gauge, as shown in Figure 3, is used to measure the wire sizes from 0 to 36 AWG. The wire must fit the slot not the circular hole past the slot, to obtain a proper size, when using this gauge.

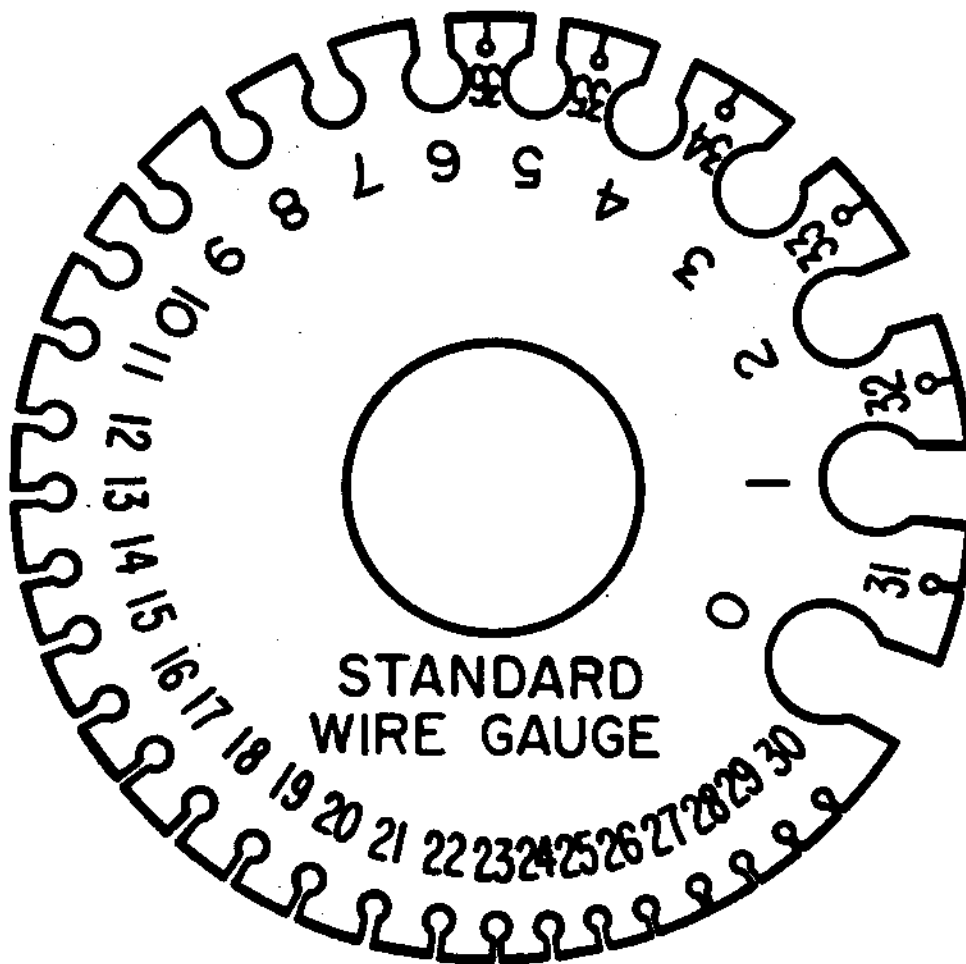

Figure 3 - AWG

TABLE 2 - Standard Annealed Solid Copper Wire
American wire gauge -- B & S

Gauge Number	Diameter (mils)	Cross Section		Ohms per 1000 ft		Ohms per mile 25°C (-77°F)	Pounds per 1000 ft
		Circular mils	Square inches	25°C (-77°F)	65°C (-149°F)		
0000	460.0	212,000.0	0.166	0.0500	0.0577	0.264	641.0
000	410.0	168,000.0	0.132	0.0630	0.0727	0.333	508.0
00	365.0	133,000.0	0.105	0.0795	0.0917	0.420	403.0
0	325.0	106,000.0	0.0829	0.100	0.116	0.528	319.0
1	289.0	83,700.0	0.0657	0.126	0.146	0.665	253.0
2	258.0	66,400.0	0.0521	0.159	0.184	0.839	201.0
3	229.0	52,600.0	0.0413	0.201	0.232	1.061	159.0
4	104.0	41,700.0	0.0328	0.253	0.292	1.335	126.0
5	182.0	33,100.0	0.0260	0.319	0.369	1.685	100.0
6	162.0	26,300.0	0.0206	0.403	0.465	2.13	79.5
7	144.0	20,800.0	0.0164	0.508	0.586	2.68	63.0
8	128.0	16,500.0	0.0130	0.641	0.739	3.38	50.0
9	114.0	13,100.0	0.0103	0.808	0.932	4.27	39.6
10	102.0	10,400.0	0.00815	1.02	1.18	5.38	31.4
11	91.0	8,230.0	0.00647	1.28	1.48	6.75	24.9
12	81.0	6,530.0	0.00513	1.62	1.87	8.55	19.8
13	72.0	5,180.0	0.00407	2.04	2.36	10.77	15.7
14	64.0	4,110.0	0.00323	2.58	2.97	13.62	12.4
15	57.0	3,260.0	0.00256	3.25	3.75	17.16	9.86
16	51.0	2,580.0	0.00203	4.09	4.73	21.6	7.82
17	45.0	2,050.0	0.00161	5.16	5.96	27.2	6.20
18	40.0	1,620.0	0.00128	6.51	7.51	34.4	4.92
19	36.0	1,290.0	0.00101	8.21	9.48	43.3	3.90
20	32.0	1,020.0	0.000802	10.4	11.9	54.9	3.09
21	28.5	810.0	0.000636	13.1	15.1	69.1	2.45
22	25.3	642.0	0.000505	16.5	19.0	87.1	1.94
23	22.6	509.0	0.000400	20.8	24.0	109.8	1.54
24	20.1	404.0	0.000317	26.2	30.2	138.3	1.22
25	17.9	320.0	0.000252	33.0	38.1	174.1	0.970
26	15.9	254.0	0.000200	41.6	48.0	220.0	0.769
27	14.2	202.0	0.000158	52.5	60.6	277.0	0.610
28	12.6	160.0	0.000126	66.2	76.4	350.0	0.484
29	11.3	127.0	0.0000995	83.4	96.3	440.0	0.384
30	10.0	101.0	0.0000789	105.0	121.0	554.0	0.304
31	8.9	79.7	0.0000626	133.0	153.0	702.0	0.241
32	8.0	63.2	0.0000496	167.0	193.0	882.0	0.191
33	7.1	50.1	0.0000394	211.0	243.0	1,114.0	0.152
34	6.3	39.8	0.0000312	266.0	307.0	1,404.0	0.120
35	5.6	31.5	0.0000248	335.0	387.0	1,769.0	0.0954
36	5.0	25.0	0.0000196	423.0	488.0	2,230.0	0.0757
37	4.5	19.8	0.0000156	533.0	616.0	2,810.0	0.0600
38	4.0	15.7	0.0000123	673.0	776.0	3,550.0	0.0476
39	3.5	12.5	0.0000098	848.0	979.0	4,480.0	0.0377
40	3.1	9.9	0.0000078	1,070.0	1,230.0	5,650.0	0.0299

5. Specific Resistance or Resistivity

Specific Resistance or Resistivity, is the resistance, in ohms, offered by one unit volume, of a substance, to the flow of electrical current. Resistivity is the reciprocal of conductivity, and vice versa. It is represented by the Greek letter ρ . The temperature at which the resistivity is measured must be specified.

6. Types of Conductors

A CONDUCTOR is a wire or combination of wires (not insulated from one another), suitable for carrying an electric current.

A STRANDED CONDUCTOR is a conductor composed of a group of bare wires twisted together.

A CABLE is either a stranded conductor, single-conductor, or a combination of conductors insulated from one another (multiple-conductor cable). The term cable is a general one; In practice, it is usually applied only to the larger sizes of conductors. A small cable is more often called a stranded wire or cord. Cables may be bare or insulated. The insulated cables may be sheathed (covered) with lead, or protective armour.

Another common conductor is the BUS BAR. A high voltage bus bar is frequently just a hollow aluminum or copper tube, as is found on the main generator output. A low voltage bus may consist of flat straps or rectangular bars. Bus bars are commonly used, bare, but they can be covered with an insulating material, if the specific application requires insulation.

Figures 3 and 4 illustrate various configurations of wire, cable, and bus bar. Shown also, are typical sizes and applications.





<u>Type</u>	<u>Illustration</u>	<u>Application</u>
Solid round		Bare or insulated wire for power work; insulated for magnet wire
Solid grooved		Trolley contact wire
Solid, square		Magnet wire and windings for electrical equipment
Solid, rectangular		Magnet wire and windings for electrical equipment, bus bars
Tubular		Bus bars, IPB

Figure 3: Configurations of Electrical Conductors

<u>Type</u>	<u>Illustration</u>	<u>Application</u>
Standard, concentric-stranded		Bare or insulated cables
Bunch Stranded		Flexible cords and fixture wire
Annular concentric-stranded with rope core		Varnished-cambriac-insulated and solid type paper-insulated single-conductor cables.
Stranded (All Aluminum)		Bus bars
Annular aluminum, stranded with steel core (ASCR)		Bus bars

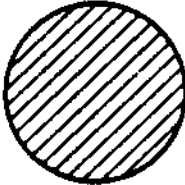
Figure 4: Configurations of Electrical Conductors

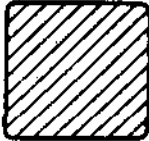
7. Selection of Conductor Size

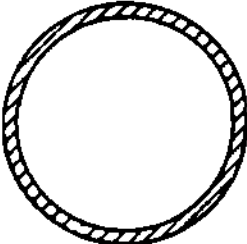
Selection of conductor size refers mainly to the area of cross-section of the conductor. The following considerations are made in this process.

- (a) Current carrying capacity of the conductor (normally referred to as the ampacity of the conductor). Each size conductor is rated to carry a certain maximum current, safely. If this current rating is exceeded, then the conductor will overheat. To overcome this problem, a sufficiently large conductor size is used, with a rating higher, than the current expected in the circuit.
- (b) Voltage drop allowable in the conductor. All conductors have an inherent resistance R . When a current of I amperes flows through it, a voltage drop of V volts occurs across the conductor. This has two effects:
 - (i) Voltage at the load is reduced by the amount of internal voltage drop in the cable.
 - (ii) As the load current varies, internal voltage drop will also vary. This results in poor voltage regulation at the load end.

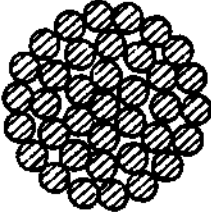
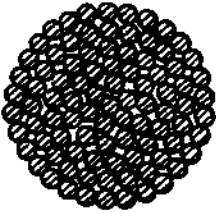
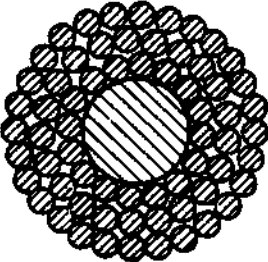
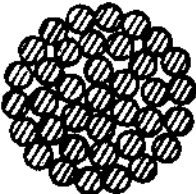
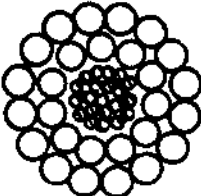
To reduce the internal voltage drop in the cable, it is necessary to reduce the resistance of the conductor.

8. Connecting Aluminum Conductors

Aluminum oxidizes almost instantly. The aluminum oxide layer formed on a conductor surface is hard, and it is a very poor conductor of electricity. When connecting aluminum conductors, the following special precautions must be taken:

- (a) Non-oxidizing lubricant must be used.
- (b) A special connector must be used. It breaks the oxide film and provides a good metal-to-metal contact.
- (c) A special connector must be used for ACSR conductors. This connector is shown in Figure 5, below.

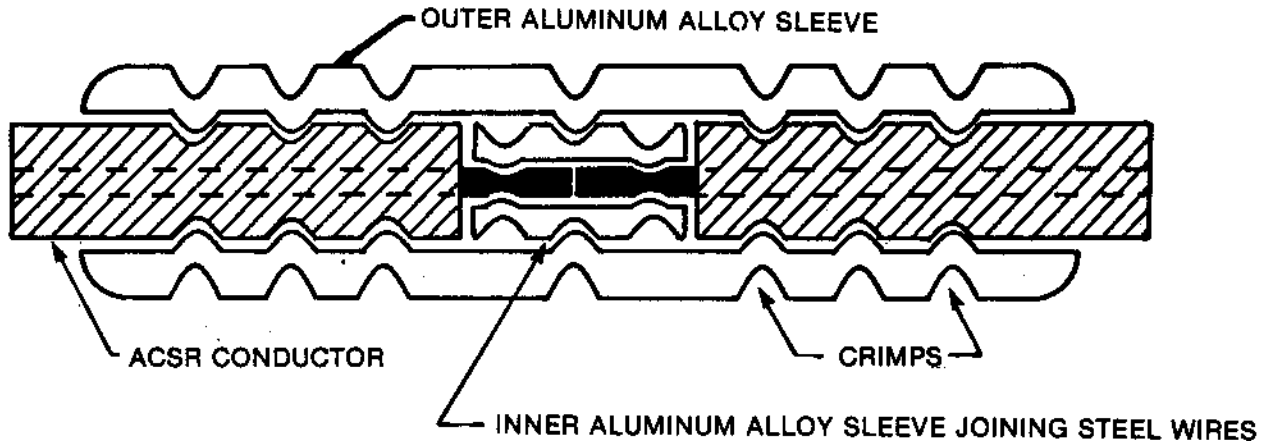

Figure 5: Special connector for joining ACSR conductors

Note, in the figure above, that aluminum sleeves are used to join the ACSR conductors together. The illustration shows only a few crimps in the sleeve. However, in actual practice many more crimps would be made to ensure that there is sufficient contact area between the ACSR conductor and the aluminum alloy sleeve.

9. Conductors and Cables in a Power Plant

In power plants, power conductors and cables are used for:

- (a) Taking power from the electrical generator to the main transformer. (These conductors are known as the Isolated Phase Bus).
- (b) Taking power from the main transformer to the Hydro Grid. (This is done via overhead ACSR conductors or aluminum conductors for short distances).
- (c) Distributing power to the distribution panels (by means of bus bars).
- (d) Taking power from the distribution panels to the various motors, lighting and other loads. (This is done via cables).

Figure 6 shows all of the above components in a power plant. A brief discussion of each will be given on the pages that follow.

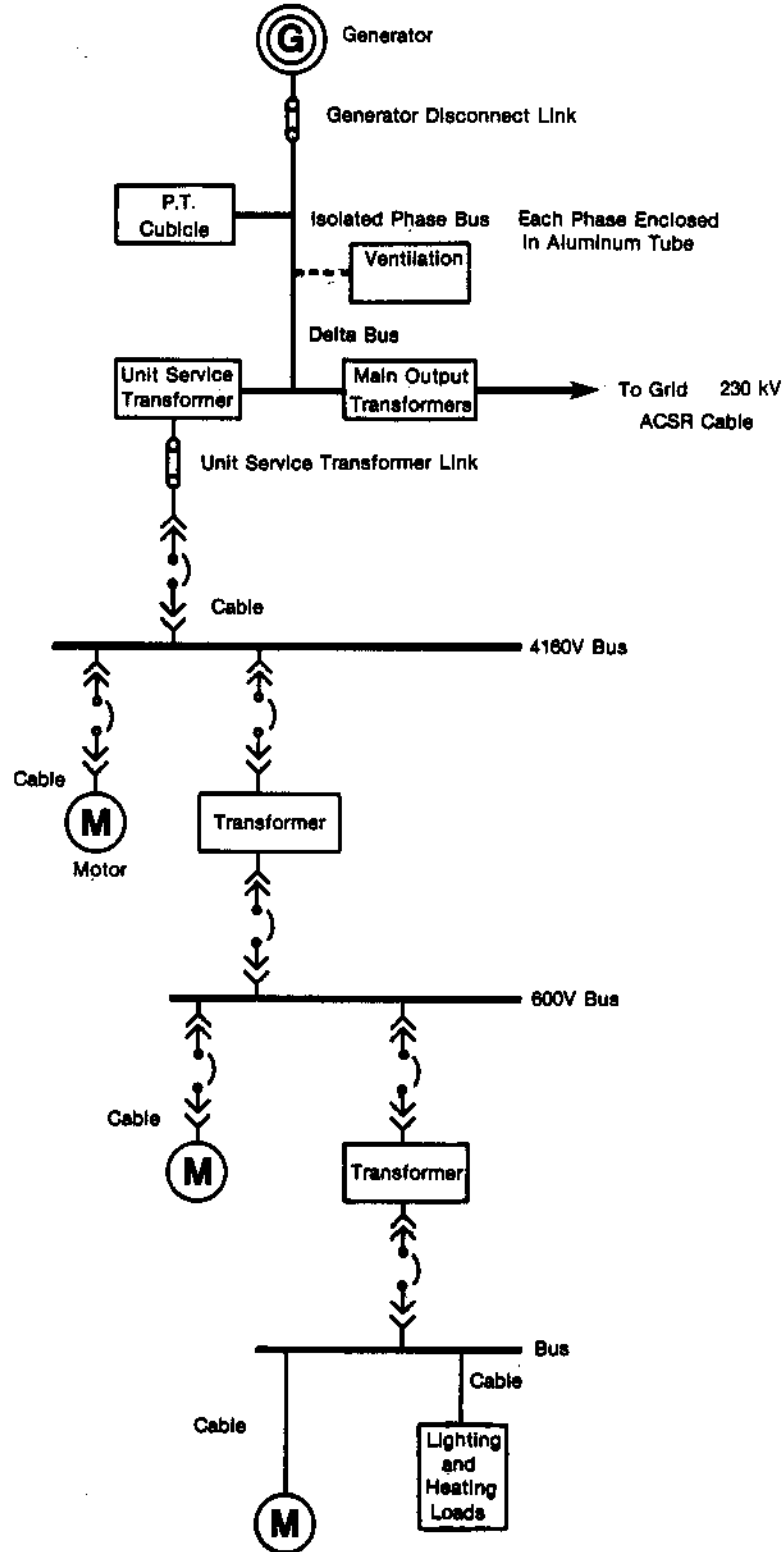
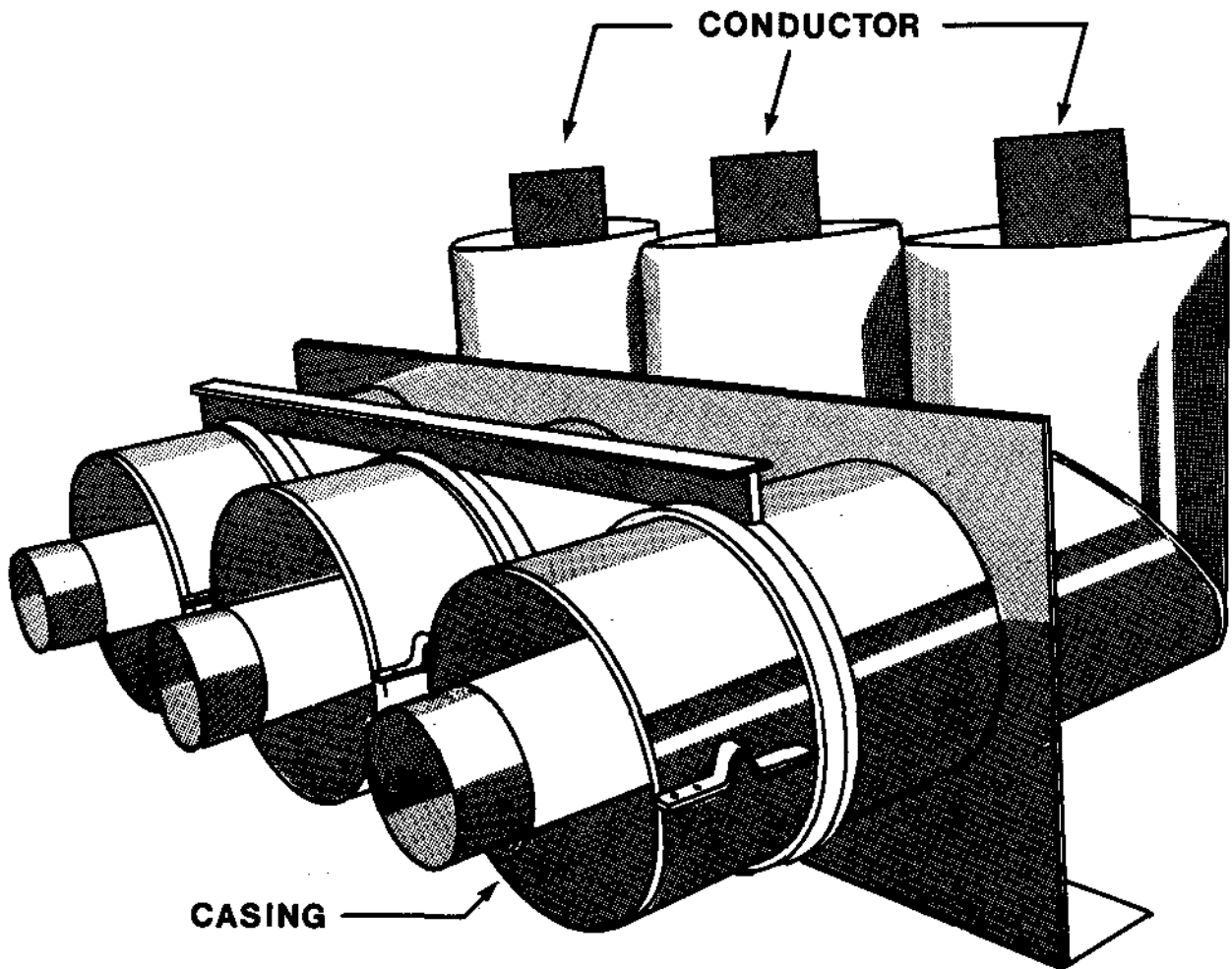

Figure 6: Buses, Conductors, and Cables in a Power Plant

9.1 Isolated Phase Bus (IPB)

The IPB takes the power from the generator to the main transformer. This conductor system carries the largest magnitude of current in the plant. At Pickering "A", the current can be as high as 16,500 amperes, and at Bruce "A", the current can be as high as 30,000 amperes. Since very large conductors are required to carry this amount of current, economics dictates the use of aluminum.

The IPB conductor is tubular and it is placed in a circular or rectangular casing to provide forced air cooling and environmental protection. Figures 7(A) and 7(B) show sections of the IPB. Cooling is necessary to remove large I^2R heat developed and this is provided by forced air circulation.



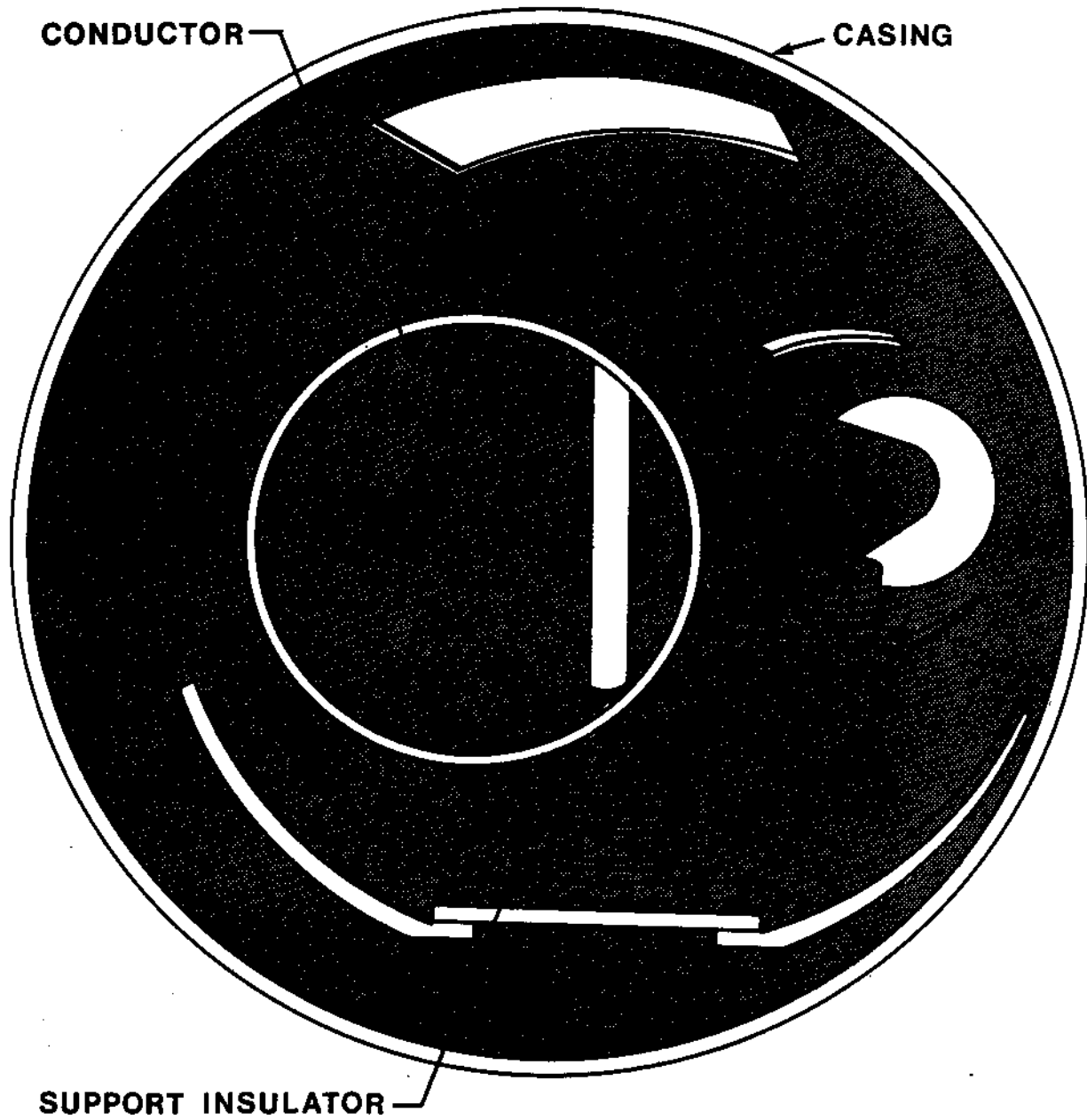

Figure 7(B): Isolated Phase Bus mounted on support insulators in the cooling duct. (Only one conductor is shown)

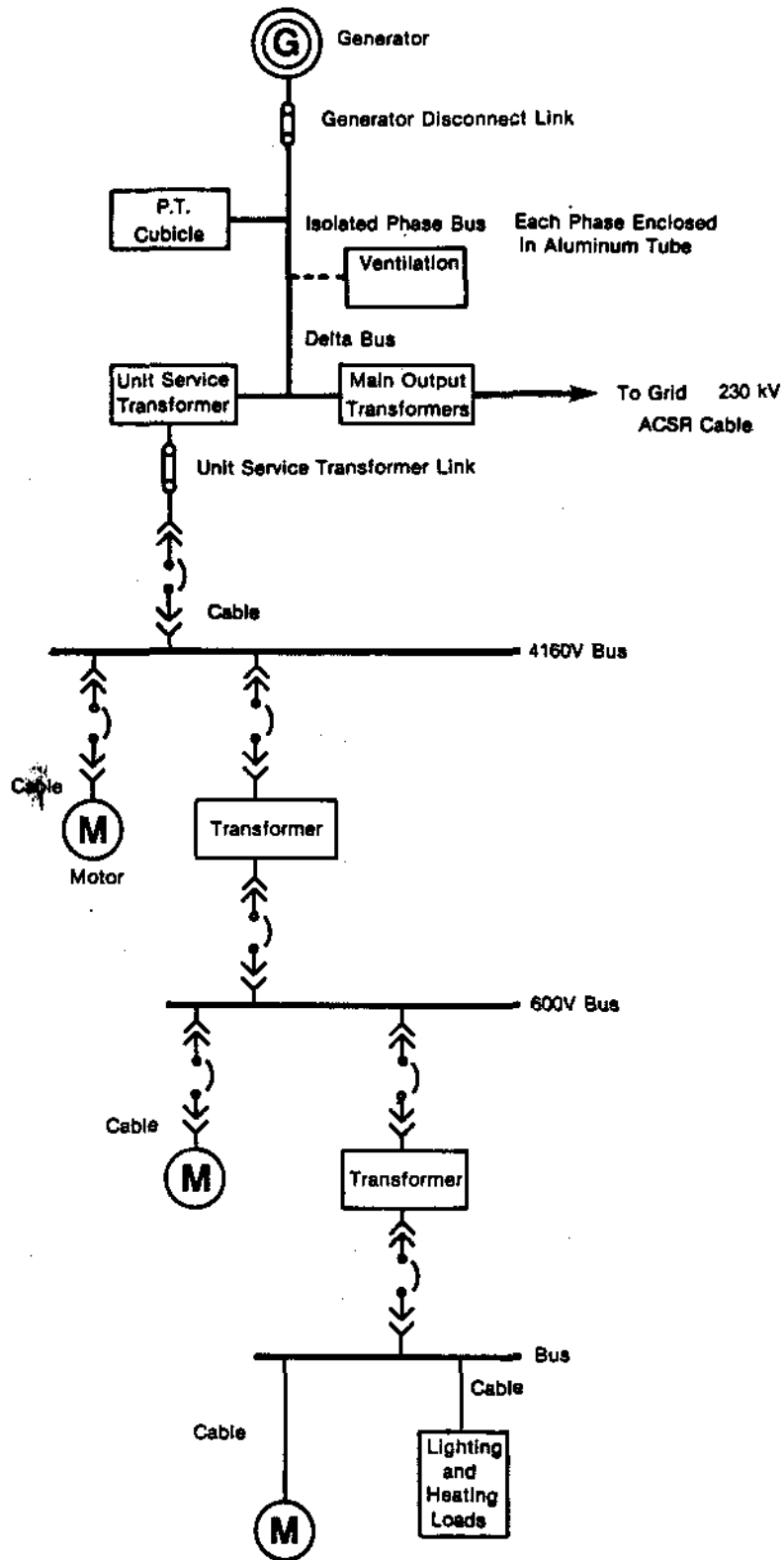

Figure 8: Conductors and Cables in a Power Plant

9.2 Generator Transformers-to-Switchyard Connection

The output of the main transformer is at 230 kV or 500 kV. As a result, current is much smaller here than in the IPB. To carry this smaller current, small size conductors are used. Conductors used are normally ACSR types. Stranded aluminum cable may also be used for short distances.

9.3 Power Distribution at the Panel

A bus is a conductor which serves as a common connection to two or more circuits. Power into the panel is brought by a cable and fed to a bus. A bus can feed many circuits connected to it, as shown in Figure 9, below.

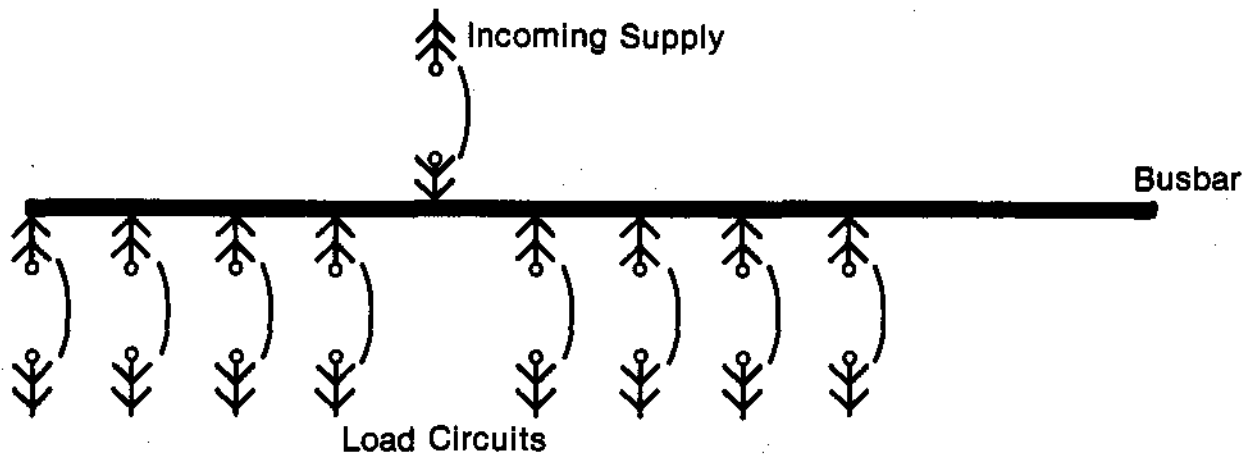

Figure 9: Single line diagram showing a bus bar with an incoming supply and load circuits.

9.3.1 Types of Bus Bars

Bus bars are divided into the following categories:

(a) Indoor Bus Bars

This type of bus bar is used at 600 V, 4160 V and 13800 V, in nuclear generating stations. They can be either:

- (i) Insulated.
- (ii) Non-insulated.

(b) Outdoor Bus Bars

They can be:

- (i) tubular types. The tube can be either aluminum or copper.
- (ii) Flexible type; constructed from ACSR. This type of bus bar is used in 115 kV, 230 kV and 500 kV applications. It connects to and from the main transformer terminals, and the disconnect switches to the transmission line.

The flexible type of outdoor bus bar is supported from overhead structures, using strain-relief type insulators and the tubular type is supported from pedestal type insulators. Flexible connectors are used between the tubular bus bars to allow for expansion and contraction of the joints.

10.0 Care of Cables

In a power plant if the cables are properly cared for, they will give trouble-free service for the life of the station. Cable failure is usually attributable to one of the following:

(a) Heat (Refer to PI 30.21-2, Section 4.1.3)

Cable insulation is designed to withstand a maximum rated temperature. Any increase above this rating will permanently damage the insulation. To prevent this condition:

- (i) Adequate ventilation must be provided when the cables are carrying current.
- (ii) They must not be installed on hot surfaces.
- (iii) Temperature rating of the insulation used, must be selected to suit the application.

(b) Cold

Insulation is also rated for a minimum sub-zero temperature. If it is subjected to colder temperatures than what it is rated for, the insulation will become brittle and will likely develop cracks. To prevent this from happening:

- (i) Cables installed in areas where sub-zero temperatures are expected, must be rated to withstand such temperatures.
- (ii) Handle the cable with care.

(c) Fire

Some cable insulation materials contain fire retardants, but many types do not. To prevent fires, keep flammable products away from the cable areas.

(d) Moisture

Moisture will destroy some insulation materials, such as paper. On the other hand, moisture will reduce the insulation properties of all types of insulators, which

can lead to insulation failure. The outer sheath of the cables is designed to be waterproof. If damage to the outer sheath occurs, moisture will penetrate the insulation.

(e) Physical Damage

Physical damage to cables occurs by objects hitting or striking the cables. Physical damage can occur by improper installation, such as installing cables over sharp edges.

(f) Radiation

The chemical and physical properties of insulating materials are affected by radiation. Plastic type insulating materials are affected most severely by radiation, particularly the wiring harnesses on fuelling machines.

(c) IPB

(d) Large Generators and Transformers

(e) Bus Bars

4. Define the following units (Section 4):

(a) Square MIL

(b) Circular MIL

(c) AWG

(b) What metal is used for the IPB?

(c) What is the shape of the IPB?

(d) How and why is additional cooling provided to the IPB?

9. With regards to bus bars, answer the following (Section 9.3, 9.3.1):

(a) What is a bus bar?

(b) What metals are used for bus bars?

(c) What two types of indoor bus bars are there?

(d) What two types of outdoor bus bars are there?

10. List six factors which can damage a cable and must be considered when discussing cable care (Section 10).

S. Rizvi
R. Coulas