

CHAPTER 9

CONTAMINATION CONTROL

INTRODUCTION

Contamination is radioactive material where it isn't supposed to be. It can be in solid, liquid or gaseous form.

Although the systems at Point Lepreau are designed to contain the radioactive materials they process, there are many ways in which these materials can escape to cause a **contamination hazard**. For example, faulty design, equipment failures, chronic leaks, operator errors and maintenance work can all cause contamination hazards. We must know how to deal with contamination to avoid unnecessary internal and external radiation exposure.

This chapter is about contamination control. It covers a wide range of activities; namely identifying the different types of contamination and assessing the hazard, preventing the contamination from spreading, selecting appropriate protective measures and cleaning it up. We will deal with these topics one at a time, starting with surface contamination.

SURFACE CONTAMINATION

If radioactive material has been deposited on surfaces (such as walls, floors, benches), it is called **surface contamination**. It may be loosely deposited, much like ordinary dust, or it may be quite firmly fixed by chemical action. This distinction is important, and we classify surface contamination on the basis of how easily it can be removed:

1. Loose Contamination (Easily Removed)

This is surface contamination that can easily be removed with simple decontamination methods. For example, if the surface is cleaned up by wiping it with a damp rag, we are dealing with loose contamination.

2. Fixed Contamination (Hard to Remove)

Surface contamination that is quite firmly attached to the surface and cannot be removed by normal housekeeping methods is called fixed contamination.

SOURCES OF SURFACE CONTAMINATION

The surface contamination found at PLGS is largely beta/gamma emitting fission and activation products. It can be produced and spread in quite a variety of ways. Some examples are given below:

1. Volatile fission products (i.e., vapours or gases) escaping from the PHT system will decay to particulates and deposit on surfaces. Widespread surface contamination can result (e.g., almost the whole Reactor Building could become contaminated).
2. Liquid leaks from seals, packing, joints, etc., will cause **liquid contamination** of the surfaces it drips or pours on. Once the liquid is removed (by wiping, drainage or evaporation), surface contamination will remain.
3. Radionuclides will plate out on the inner surface of pipes, valves, etc. Zr-95 and Nb-95 are our biggest offenders.
4. Maintenance work calls for handling of contaminated parts and equipment. Without special precautions, we'll end up with contaminated hands, face, hair, clothing, tools, floors and surrounding objects. Inhalation and even ingestion of contamination is likely.
5. Machining or grinding of contaminated or radioactive parts will produce radioactive dust; this will settle out as surface contamination.
6. Tritium in the form of water vapour can condense or be absorbed on surfaces to create a form of surface contamination. Even if the tritium in the air is then removed by ventilation systems, the tritium that is held up in the walls and floors will be released to contaminate the air again. (This is one of the reasons why the Reactor Building walls are painted with non-porous epoxy paint.)
7. Carelessness in monitoring yourself or any items you bring out of the active areas can cause widespread contamination.

HAZARDS OF SURFACE CONTAMINATION

Loose Contamination

Loose contamination is a more serious hazard than fixed contamination, because it can lead to an internal exposure. There are two ways in which loose contamination can enter the body. One is by transfer to exposed skin (i.e., hands and head) from which it may find its way into the mouth. The other is by inhalation as a result of **resuspension**. This means that the work activity and traffic in the area has stirred up the loose contamination so that some of it becomes airborne and can be inhaled.

You will appreciate that there is a need to restrict food handling in areas that can become contaminated with loose contamination. If work areas do become contaminated, the loose contamination should be cleaned up as soon as possible, so that it is prevented from spreading.

Although almost all contamination is beta-gamma emitting, there is the possibility of alpha contamination in any fuel handling areas. The Spent Fuel Bay and Decontamination Centre are equipped with Herfurth Hand & Shoe Monitors set up for alpha as well as β, γ monitoring (as discussed in the third paragraph of page 138).

Fixed Contamination

If the contamination is fixed, it cannot be re-suspended or transferred to your skin, and therefore the hazard is an external one only. Unless the level of contamination is very severe, the gamma dose rate will be small and external exposure will be significant only in contact with, or very close to, the contaminated surfaces. The beta dose rate can be quite high at contact. A value of 1 mSv/h at contact for a contamination level of 300 - 500 Bq/cm² is fairly representative. The beta dose rate decreases rapidly with distance (90% of the betas are absorbed in one metre of air): so in normal work the main hazard is to the hands which are in contact with or close to contaminated equipment.

CONTAMINATION CONTROL LIMITS

Contamination can be measured. So we need numbers to describe the measurements. They are expressed in terms of **Contamination Control Limits or CCLs**.

$$1 \text{ CCL} = 50 \text{ kBq/m}^2 = 5 \text{ Bq/cm}^2.$$

How did we arrive at this number? Basically, contamination levels below 1 CCL aren't much of a problem, but above 1 CCL we want to impose some controls. 1 CCL of contamination gives about 15 µSv/h to the underlying skin. Activity at the CCL level is low enough to present a minimal radiation hazard, but yet high enough to be detectable with portable contamination meters.

Table 9.1 lists these CCLs. The limits are for fixed contamination. They do not apply to loose contamination. Why? Because if loose contamination is found it must be cleaned up immediately before it has a chance to be tracked all over the place, or it must be contained by setting up a Rubber Area (more on this later).

We have located Hand & Shoe monitors and semi-portable friskers throughout the station at exits from areas where there is a potential for loose contamination. The semi-portable friskers are set to alarm for contamination levels of 1 CCL on either surface of your hands (palm or back) or on the soles of your shoes. The Herfurth Hand & Shoe Monitors and Full-Body Monitors are more sensitive, and so they are set to alarm at a lower level of 0.5 CCL. Since the monitors can't tell whether they are measuring fixed or loose β,γ contamination, the alarm level applies to the total contamination.

However, the intent is that **no** contamination leaves the station. In practice, this means that if you even suspect there might be contamination on your hands, you should wash them before you monitor. You must also check any equipment you take out for fixed and loose contamination by the methods described later on.

TABLE 9.1. FIXED CONTAMINATION CONTROL LIMITS (β,γ)

Body Surfaces, Personal Clothing, Materials removed from the Station	1 CCL
Respirators after cleaning	1 CCL
Protective Clothing after cleaning	5 CCL
Plastic suits after cleaning	50 CCL

If you alarm a Full-Body Monitor, check the display and use the frisker to discover the location and level of contamination. Call Work Control, and try to establish the source of the contamination. You may leave the station with contamination levels below 1 CCL on your body or clothing provided decontamination has been tried and the source is known.

If all the activity on your hands were loose mixed fission products at 1 CCL, and if all of this activity were transferred to your mouth and ingested, and if you did this once every day, you would be unlikely to exceed the annual dose limits for all practical fission product mixes. You must admit that this is a pretty far-fetched set of circumstances.

For respirators the limit is the same; no loose contamination is permitted, because the inhalation pathway is generally more restrictive than the ingestion pathway. The limit for protective clothing is five times greater than for respirators, because even if residual traces of loose contamination remain after cleaning, this loose contamination is much less likely to be inhaled than would be the case for respirators. Finally, for plastic suits after washing we use a limit of 50 CCLs.

The cleaning techniques we use for respirators and protective clothing will remove any loose contamination, so that when we monitor them, we will be measuring fixed contamination only.

MEASURING SURFACE CONTAMINATION

There are two methods used for monitoring surface contamination. One is the **Direct Method**, which measures the amount of fixed and loose contamination, and the other is the **Indirect** or **Smear Method**, which measures loose contamination only. Since the levels of contamination that we are trying to measure are quite low, sensitive instruments are required. For beta-gamma contamination measurements, we use "pancake" Geiger detectors. They have a very thin mica window (0.01 mm), which most beta particles are able to penetrate (but not tritium betas).

Fig. 9.1 shows the pancake detectors that we use with the Portable Contamination Meter shown on page 140. Their efficiency is typically 20% for detecting beta particles emitted from a surface about 1 cm away. This high efficiency is the result of using the very thin window — the drawback is that because the window is so thin, the tubes are quite fragile and must be handled with care. The purpose of the wire screens that you can see in Figure 9.1 is to protect the thin mica window.



Fig. 9.1. Pancake Geiger Detectors

The counting efficiency depends on how close to the contaminated surface you hold the detector. Fig. 9.2 shows the different count rates from a pancake detector held at various distances from a 500 Bq technetium-99 source. This source has the same area as the detector (15 cm^2) and emits low energy beta particles of $E_{\text{max}} = 0.29 \text{ MeV}$. You can see that unless you get really close to the contaminated surface, you're wasting your time.

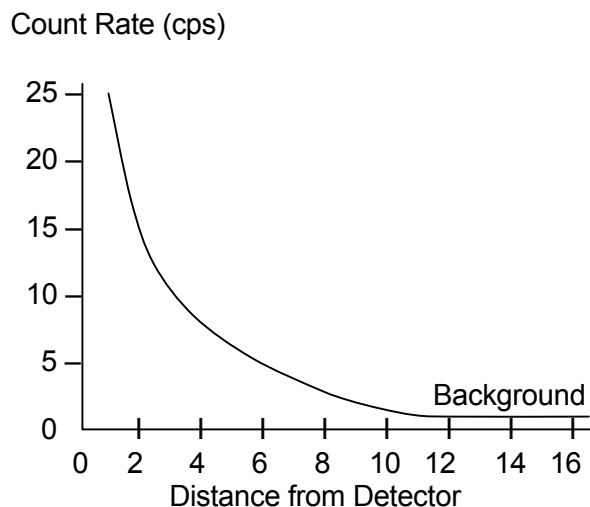

Fig. 9.2. Count Rate vs Distance

The Direct Method

Use this method to measure surface contamination directly:

1. Select an instrument with one of the probes shown in Fig. 9.1. Do the pre-operational checks. If the instrument has a speaker, switch it on; it'll help you find contamination.
2. Select a slow response time and measure the background count rate while holding the probe well away from the surface you are going to monitor. If the background is above 50 cps, you can't use this procedure to find contamination (it's like listening for a fart in the Boiler Room).
3. Select a fast response time, and taking care not to contaminate the probe by touching the surface, move the detector slowly across the surface at a distance of about 1 cm. If you move the detector faster than 2 to 3 cm/sec, you are wasting your time, because the instrument won't register the contamination before you have passed by it.
4. If the count rate increases above the background reading, select a slow response time (so that the fluctuations in the count rate will be smoothed out) and hold the probe above the detected activity for a long enough time (about 10 to 20 seconds) to obtain a steady, accurate reading.
5. Subtract the background count rate from this reading and compare this result to the count for a surface uniformly contaminated to 1 CCL. The number of cps per CCL will be different for instruments with different efficiencies or probe areas. At Point Lepreau, contamination meters are labelled with the number of cps per CCL.

Fig. 9.3 shows Gerry Black monitoring his hands for contamination with a semi-portable contamination meter. This combination is known as a **Frisker**; you can use it to frisk yourself for contamination at various locations throughout the plant. As I said before, good frisking technique requires that you move the detector **slowly** over the surface being monitored, and **close to it**. **Anything else is a complete waste of time.** A good contamination survey takes time, but, hey, you're still getting paid.



Fig. 9.3 Using the RM-14 Frisker



Fig. 9.4. Using the $\alpha/\beta,\gamma$ Contamination Monitor to Check a Book

Disadvantages of the Direct Method

1. It isn't possible to make a direct measurement of surface contamination when a high gamma background is present. It completely swamps any increased count rate from contamination. We have found that a gamma background of 1 $\mu\text{Sv/h}$ gives about 5 cps with a pancake detector. If the background is too high, all you can do is move the equipment you are trying to monitor to a low background area. If you can't move it, tough.
2. A direct measurement can't tell you if the contamination is fixed or loose, and you need to know this. If the contamination is fixed, it can't spread. If it is loose, we are much more concerned about it. In fact, you must clean it up right away to stop it getting tracked all over the place.

The Indirect (Smear) Method

This is used to detect loose contamination. The measurement is made on **Smears**, which are small discs of filter paper. You rub them over the surface to pick up some of the loose contamination that may be present. You then count the activity collected on the filter paper with a suitable detector. (You use the same detector as for the direct measurements.) You would use this method for checking tools, instruments and other small objects. What you do is:

1. Obtain smears and envelopes from a Smear Counting Station.
2. Wearing a pair of disposable or cotton gloves, hold the smear on the edge with your thumb and index finger. Rub it over the surface with light pressure as shown here.
3. Swipe an area of about 300 cm^2 (i.e. about half the size of this page) in an "S" shape.
4. Put the smears in separate envelopes. Number or otherwise identify the smears so that you can keep track of where any particular smear was taken.
5. Take them to a **Smear Counting Station**. At Point Lepreau, we have chosen to use scalers rather than ratemeters for counting smears (the ones shown in Fig. 6.19, page 146).
6. Check that the smear holder is empty and measure the background count accumulated in 60 seconds.
7. Insert the smear into the shielded smear holder (dirty side up), and restart the scaler to measure the count accumulated in 60 seconds.
8. The difference in counts is due to activity picked up on the smear.



Fig. 9.5. Taking a Smear

9. Don't forget to take the smear out of the smear holder and drop it into the active waste container at the smear counting station.

We really don't care how the activity on the smear relates to the activity on the surface. What we care about is if you find any activity above background on the smear, we know that the surface contains loose contamination.

The box at the right is an attempt to prove that 900 counts above background in 60 seconds corresponds to 1 CCL.

Advantages of Smears

1. They measure loose contamination only, not fixed plus loose.
2. They are not plagued by high background problems, because the smear counting stations are in low background areas. In addition, the smear holder is shielded by blocks of lead to reduce the background even further to typically less than 1 cps.

Disadvantages of Smears

1. They disintegrate on rough surfaces.
2. The smear method gives much cruder results than the direct method, because the pick-up of activity depends on how hard you press, how smooth the surface is, and whether it is dry or damp. For example, the pick-up from stainless steel should be much better than 10%, but from wood you pick up very little and on carpets you can forget it. This uncertainty is not a problem in practice, because usually we just want to know whether loose contamination is present or not. And the smear method will certainly tell you that.
3. If you monitor wet surfaces for loose contamination, the smears should be dried before they are counted. Water on the smear will absorb a lot of beta particles, so that they can't reach the detector. This will cause a serious underestimate of the loose contamination.

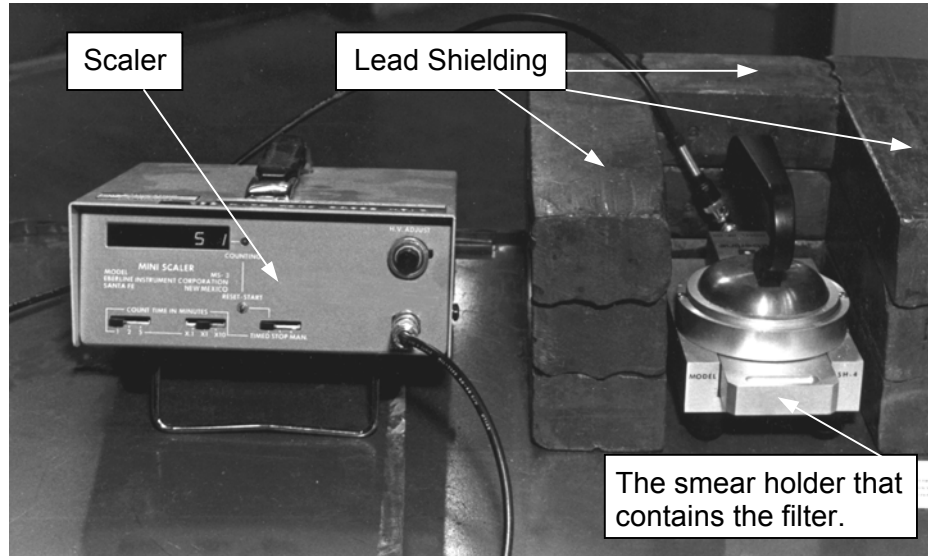

Fig. 9.6. Smear Counting Station

We assume that the smear picks up about 10% of the loose activity on the surface. If the surface holds 1 CCL = 50 kBq/m² or 5 Bq/cm² of loose contamination, you should pick up 0.5 B/cm² x 300 cm² = 150 Bq. The detector is 20% efficient for β particles, so it will register 30 cps above background, or 900 counts in 60 seconds.

4. You should check smears from highly contaminated areas with a low-range gamma survey meter (What do you mean? Of course you brought one.) If the meter reads on scale, record the gamma field and dispose of the smear in an active waste container. Such smears are far too hot to count in the smear counter and they will certainly contaminate it as well, screwing it up for the next guy, and you won't get any useful information anyway.

Indirect Method - Masslinn Mop

We use this to look for loose contamination on large areas, like floors, where the use of zillions of smears would be ridiculous.

The **Masslinn Mop** is a foam-covered, flat plastic mop head swivel-mounted to a broom handle. A clean Masslinn dust cloth is wrapped around the mop head, and then large sections of floor (typically 3 m² or so) are mopped with individual dust cloths. All cloths are labelled, and taken to a low background area where they are frisked for contamination.

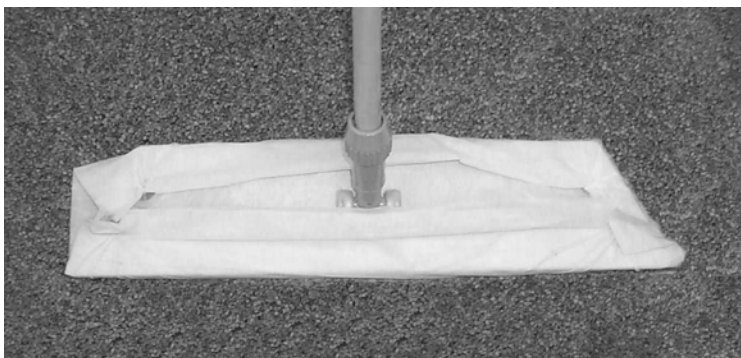

Fig. 9.7. Masslinn Mop

This is a very quick method of finding loose contamination. For surveying areas where you would not expect loose contamination, e.g., the Change Room or the Zone 2 Coffee Shop, you could smear the whole area with one cloth. If you haven't picked up any contamination, you know that the entire area is clean. On the other hand, if you find something, you have to go back and divide the area into sectors and proceed as described above. Fig. 9.7 shows a Masslinn Mop. It is nothing other than a humongous smear.

Surface Contamination Surveys

Contamination surveys are used to determine whether areas such as halls, corridors, the Control Room and the Change Room are contaminated. These areas are checked for fixed contamination and loose contamination. Comparison with previous surveys tells us whether or not contamination levels are changing. A smear is taken of the known contamination areas to find out if any contamination is migrating to the surface.

As part of the area contamination survey, things that are heavily used, such as doorways, door-knobs, hallways, handrails, and ledges that collect dust, are the best places to look for loose contamination. Exits from the Spent Fuel Bays, the Reactor Building and Rubber Areas are also good places to survey regularly.

A contamination survey is done when equipment is to be removed from a contaminated area, when equipment has contained radioactive material, and before equipment is released from the station. The survey can be performed at the site, but background radiation levels and contamination may make it necessary to take the equipment to a different location before surveying it. If necessary, the equipment can be bagged and taken to the Decontamination Centre, and it can be decontaminated there. Loose contamination is measured by smearing portions of the accessible surfaces of the piece of equipment.

Any loose contamination should be cleaned up. If this is impracticable, the area containing it should be isolated by making it a **Rubber Area**. This is a temporary contamination control area that will be described later.

Dosimetry for Surface Contamination

The TLD badge and the PAD worn on the chest are not in a position where they can indicate the dose to the hands, which normally receive the maximum dose from contaminated surfaces. The beta dose rate increases very rapidly as you get very close to the source. Therefore, when you work with high levels of surface contamination, you should wear extremity TLDs. You'll be introduced to them in the Applications Course.

AIRBORNE CONTAMINATION

So far, we have discussed contamination on surfaces. Now we'll go on to discuss contamination in the air, because the air in the Reactor Building and in many areas of the Service Building can become contaminated with airborne radioactive materials. This contamination consists of various fission and activation products that enter the air in gaseous, vapour or particulate form. There are four types of airborne contamination in CANDU plants, namely particulates, noble gases, radioiodines and tritium. Their sources, properties and hazards were described in Chapter 8.

We'll briefly review what we've already learned, and then describe how we detect and measure each of the hazards (the methods are different for all four of them, since nothing is ever easy).

PARTICULATES

Particulate activity is an internal hazard, because it can be inhaled. Transportable particulate material taken into the respiratory system will enter the blood stream and be carried to all parts of the body. Non-transportable particulates will stay in the lungs with a biological half-life of about a year. They are gradually eliminated by coming back up the respiratory tract and disappearing down the GI tract.

**The DAC for unidentified
particulates is 200 Bq/m³.**

MEASUREMENT OF PARTICULATES

An activity of 200 Bq/m^2 is much too small to be measured directly. Instead, we collect the dust from a large volume of air by passing the air through a filter paper which traps all the dust particulates. The activity of the dust collected on the filter can then be measured using a Geiger detector with ratemeter or scaler.

In some locations at Point Lepreau, the air could become contaminated with particulate activity. Can you give examples of where and when this might happen? For such cases, it is desirable to monitor the air continuously. Instruments that do this are called **Continuous Air Monitors**. These instruments really can do little more than determine if activity is present or not. To measure how much activity is actually present in the air, we need to use a **Spot Sampler**. We'll describe an example of each instrument below, and you will understand why we need both of them.

Continuous Air Monitor (CAM)

The Continuous Air Monitor operates on the principle of a pump drawing air continuously from the work area through a small glass fibre filter. Radioactive particulates in the air collect on the filter, where the activity is measured by a detector placed close to the filter. A pancake Geiger is used as the detector, and this is connected to a ratemeter and a recorder. The detector is normally mounted in a shielded castle to reduce the background. Fig. 9.8 shows the set-up.

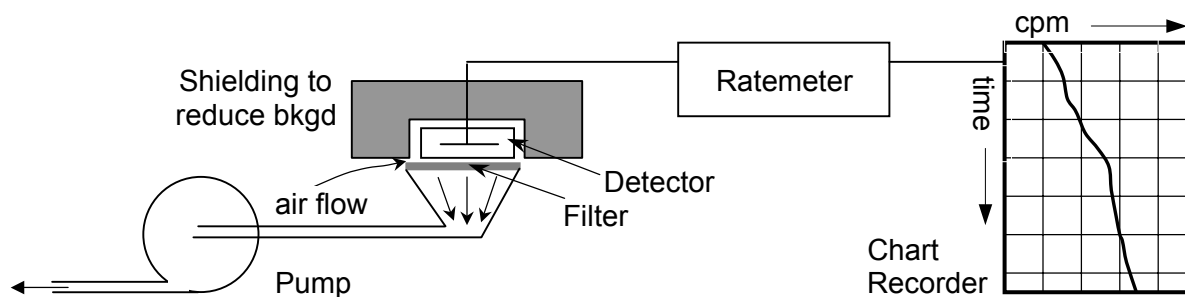

Fig. 9.8. Principle of Operation of the CAM

One of our CAMs is shown in Fig. 9.9. CAMs do not give a quantitative reading of particulate airborne concentration. Rather, as the radioactive particulates accumulate on the filter with time, the reading of the ratemeter increases. The higher the concentration of particulates in the air, the faster will be the rate of accumulation and the faster the increase in the ratemeter reading. An example of the type of recording that you might expect from air contaminated by long-lived fission products is shown in Fig. 9.10.

It is important to understand that the recorder reading does not indicate the activity in the air. The trace (rising or steady) merely tells us whether activity is present or not. The important feature is that we are alerted to a change in the activity in the air by a change in the slope of the trace.

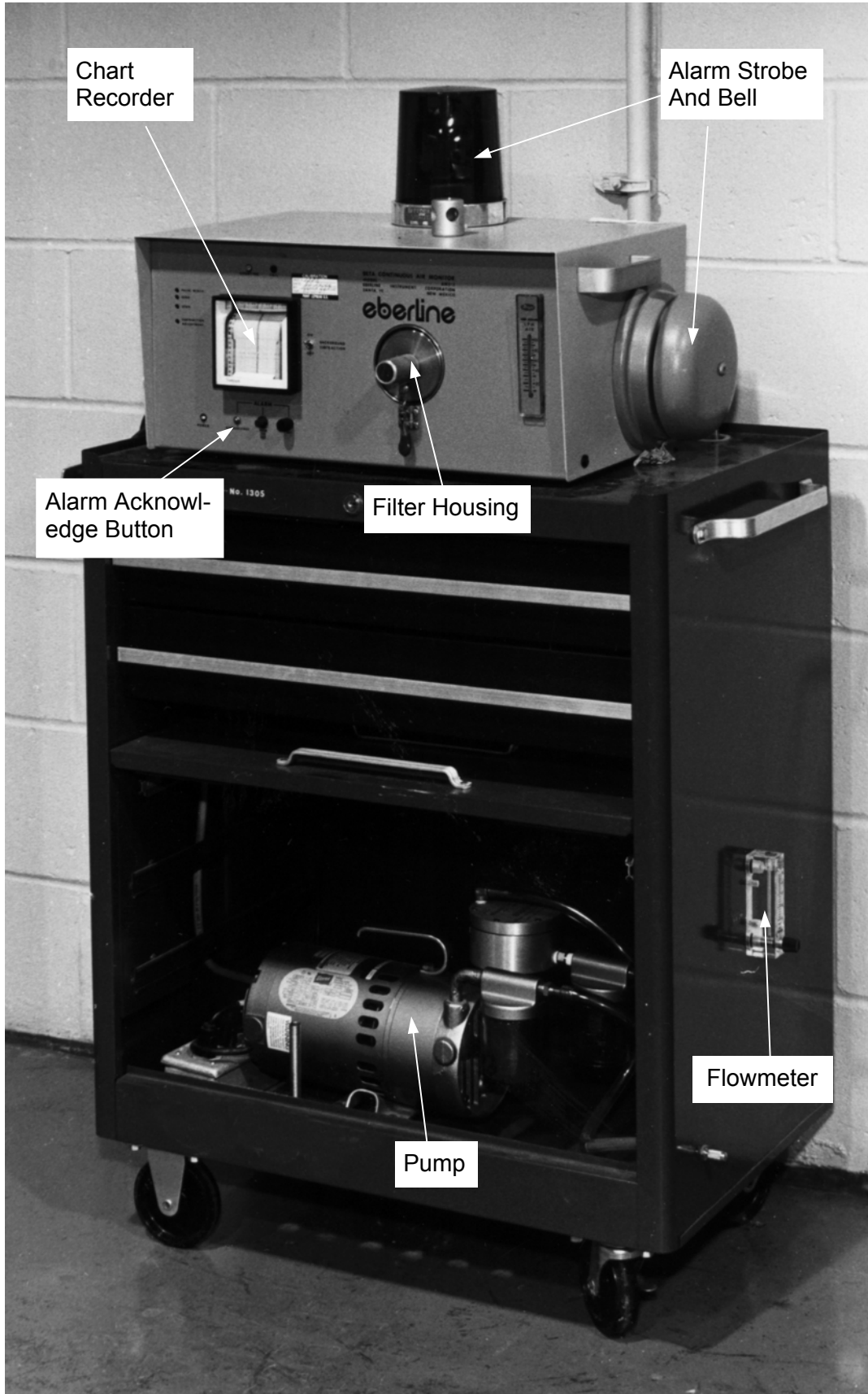

Fig. 9.9. Eberline Continuous Air Monitor (CAM)

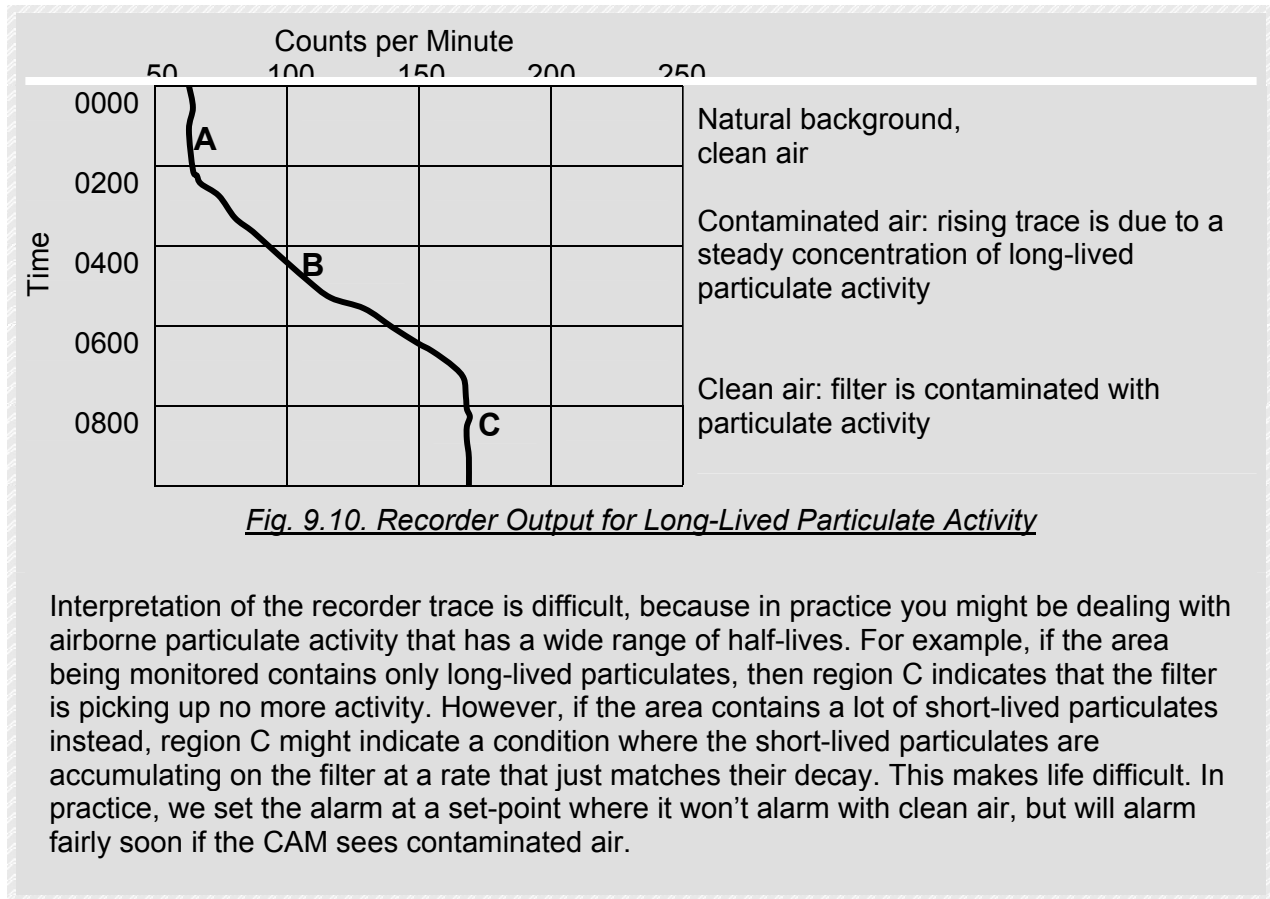

Fig. 9.10. Recorder Output for Long-Lived Particulate Activity

Interpretation of the recorder trace is difficult, because in practice you might be dealing with airborne particulate activity that has a wide range of half-lives. For example, if the area being monitored contains only long-lived particulates, then region C indicates that the filter is picking up no more activity. However, if the area contains a lot of short-lived particulates instead, region C might indicate a condition where the short-lived particulates are accumulating on the filter at a rate that just matches their decay. This makes life difficult. In practice, we set the alarm at a set-point where it won't alarm with clean air, but will alarm fairly soon if the CAM sees contaminated air.

If the CAM alarms while you are in the area, silence the bell by pushing the “Acknowledge” button (the red light will continue to flash). Leave the area and make sure that everyone else does.

Now you must use a spot sampler to get a measurement of what the airborne concentration is. It is the only way to tell for sure what's going on.

Spot Sampler

Fig. 9.11 shows a Spot Sampler. It is nothing but an air pump and a filter housing.

To take an air sample, you put a filter paper in it and switch it on. A large volume of air (450 L in our case) is drawn through it in a short period of time (5 minutes). You then remove the filter paper and take it to the nearest smear counting station, where you measure the activity collected on it. By using the graph shown in Fig. 9.12, you can easily work out the committed dose rate of the sampled air (in $\mu\text{Sv/h}$ for unidentified particulates). If you really must know how the graph is derived, see the box on the next page.

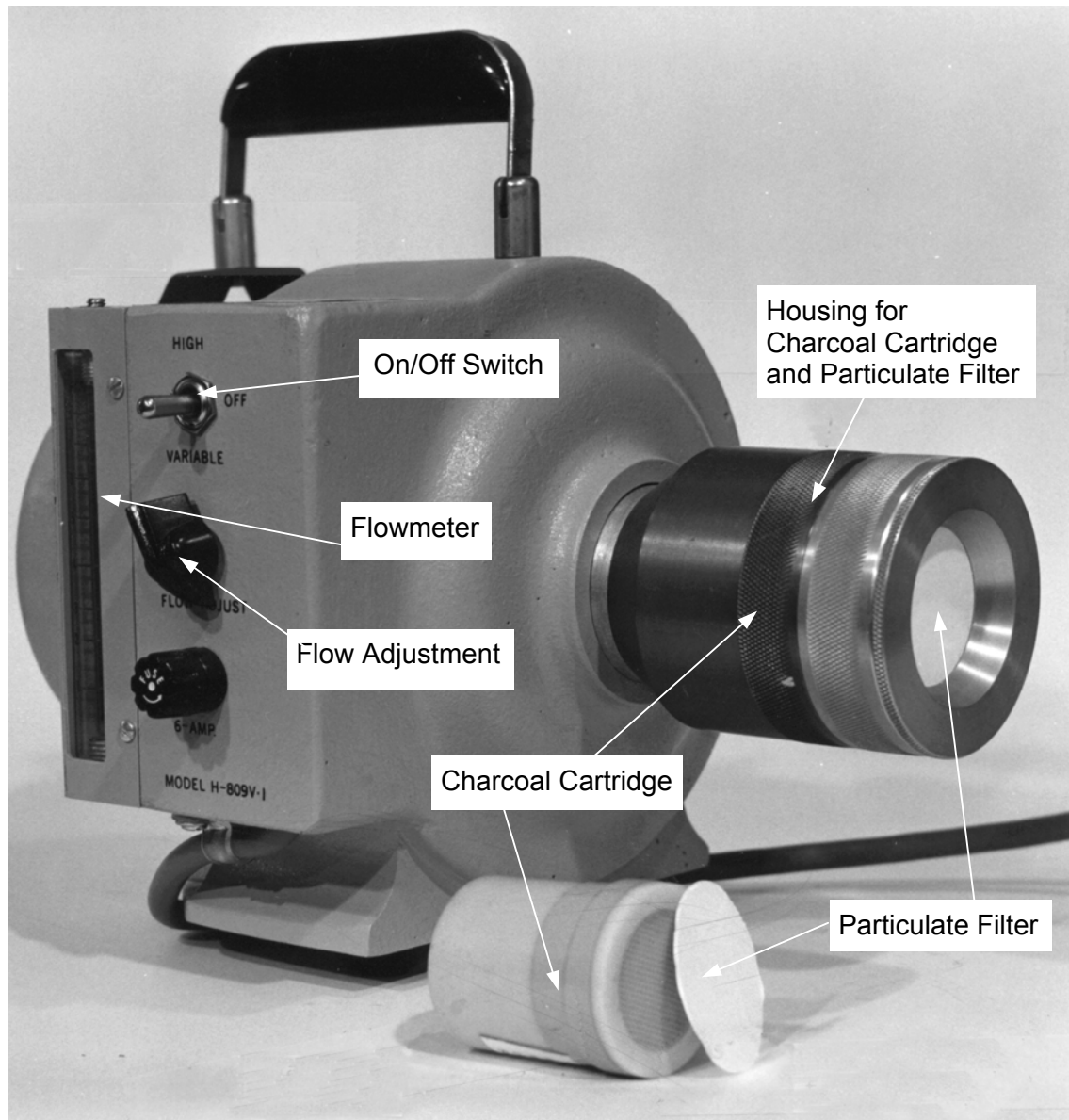

Fig. 9.11. Spot Sampler

What count rate above background corresponds to 1DAC of unidentified particulates?

Sample time = 5 minutes. Air flow is 1.5 L/s. So the volume that flows through the filter is $1.5 \text{ L/s} \times 300 \text{ s} = 450 \text{ L}$ or 0.45 m^3 .

We assume filter paper is 100 % efficient. In an atmosphere of 1 DAC it will pick up $200 \text{ Bq/m}^3 \times 0.45 \text{ m}^3 = 90 \text{ Bq}$.

Smear Counter efficiency = 20%. It will register a count rate of $90 \text{ Bq} \times 0.2 \text{ cps/Bq} = 18 \text{ cps}$. It is set to count for 1 minute, so should indicate $18 \text{ cps} \times 60 \text{ s} = 1080 \text{ counts}$ above background.

So 1080 counts/min above background corresponds to 1 DAC. This represents a committed dose rate of $10 \mu\text{Sv/h}$.

In practice, we don't expect you to do these mind-numbing sums every time you take an air sample. A graph like the one below is posted at each Smear Counting Station that translates the net counts per minute from the filter paper to committed dose rate in $\mu\text{Sv/h}$. But you have to use the standard sampling time of 5 minutes with an air flow of 1.5 L/s.

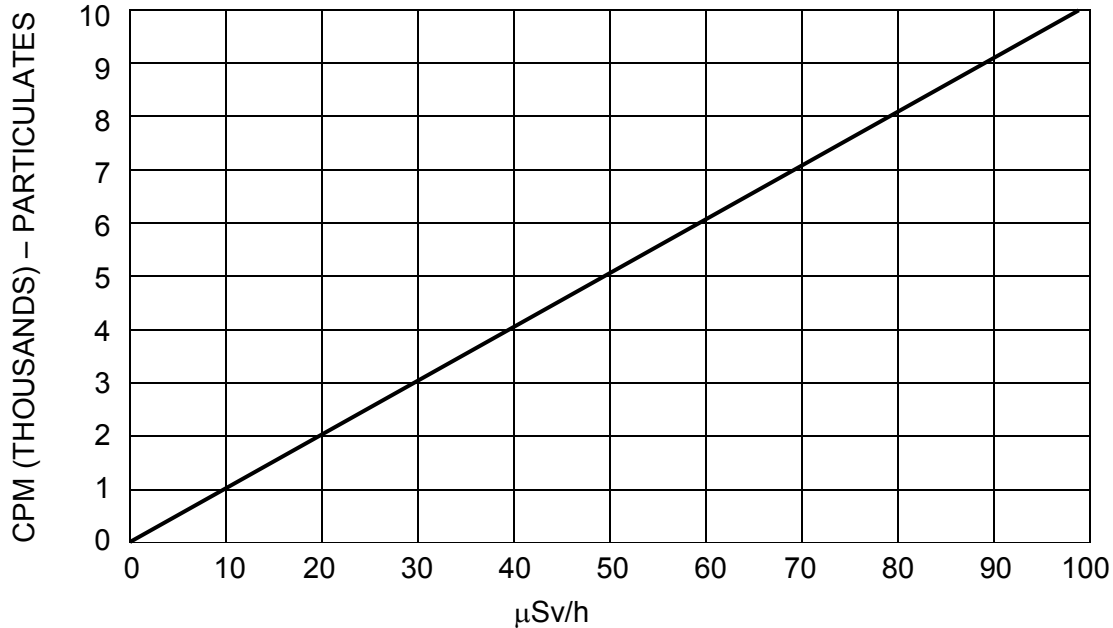

Fig. 9.12. CPM versus Committed Dose Rate for Unidentified Particulates

For example, you have taken an air sample in the Boiler Room. You count the background in the Smear Counter to be 56 cpm. You then count the particulate filter and get 4060 counts in one minute. You use the graph above to obtain how many $\mu\text{Sv/h}$ of particulate activity?

If we wanted to know which particulate we had collected, we would need a gamma spectrometry analysis done to find out how many Bq of which radionuclides were present. This can be done in the Chemistry Lab and the correct committed dose rate for the mixture obtained. If we don't want to go to all this trouble, and often we won't, we use the graph. In the example above, you'd get 40 $\mu\text{Sv/h}$.

So what do you do now to protect yourself from the particulates? You might want to wear a respirator. We have given you some guidance.

Respirators SHOULD be worn if airborne contamination exceeds 10 $\mu\text{Sv/h}$, or if the anticipated committed dose exceeds 50 $\mu\text{Sv/h}$.

Respirators MUST be worn if airborne contamination exceeds 50 $\mu\text{Sv/h}$.

For example, an occasional exposure — without protection — to 10 $\mu\text{Sv/h}$ for about half a shift may be acceptable, depending on the circumstances. The intent of this rule is to let you enter the Reactor Building for short periods of time without needing a respirator. Still, if you routinely enter such areas and work there for a couple of hours every day, you should wear a respirator to keep your dose ALARA. More on respirators on page 310.

NOBLE GASES

In Chapter 8 (page 230) we said that noble gases are an external hazard only. Since the body does not react chemically with them, they are exhaled right after they are inhaled. If you are working in a noble gas cloud, the external dose you will receive is about 1000 times greater than the internal dose. Because of this, we are only concerned about the external beta and gamma dose rates.

If, in doing an area gamma survey, you detect a radiation field that shows little variation, regardless of where you are in the room, then the radiation may well be due to radioactive noble gases. A beta survey of the area would bear this out, and should be done. You will be covered with short-lived particulate contamination if you have been in an area containing noble gases, because that's the decay product of noble gases. Therefore, you must monitor yourself for contamination. If it is short-lived particulates, the contamination will decrease with a 20-minute half-life or so. You can then either shower to remove the contamination, or just work elsewhere for an hour or so, and it will disappear on its own.

RADIOIODINE

The target tissue for radioiodine exposure is the thyroid gland. The external beta and gamma dose from radioiodine present in the air is quite negligible when compared to the committed dose to the thyroid that would result from breathing this air for the same length of time.

Measurement Of Radioiodine

We have a simple approach to radioiodine monitoring. Every time a particulate spot sample is taken, an activated charcoal filter is installed downstream of the particulate air filter (as shown in Fig. 9.11). This charcoal filter has a high efficiency for radioiodine (it also traps noble gases to some extent), but will not be able to collect any particulates, because they have already been removed from the air sample flow by the paper particulate filter.

We have already described how the activity collected on the particulate filter is measured. Once you've done that, you then use the same set-up to measure the activity collected in the charcoal cartridge.

The efficiency of the pancake Geiger detectors for the gamma photons emitted by radioiodine is much less than the efficiency for the beta particles emitted by activity collected on the particulate filters. Laboratory measurements we made showed us that the efficiency for I-131 is only 0.37%.

The reason for this is that every beta particle entering the pancake Geiger tube will produce ionisation and hence a pulse, but gamma photons will normally pass right through the tube without interacting. The beta particles from I-131 will be absorbed in the charcoal cartridge. So we can register only those gamma photons that interact and produce ionisation. This won't get us many cpm for 1 DAC or 10 $\mu\text{Sv/h}$ of I-131. Those of you who have nothing better to do can grind through the arguments in the Techie box on page 282 to show that only 40 cpm corresponds to a committed dose rate of 10 $\mu\text{Sv/h}$ of I-131. And the rest of you can take my word for it.

This number assumes that all the activity trapped in the charcoal cartridge is due to I-131. In practice, other radioiodine isotopes might be present as well as some noble gases. In this case, by assuming them all to be I-131, you will have overestimated the real committed dose rate, and that's OK because it's on the cautious side.

Similar to particulates, you'll find a graph at the smear counting station relating net counts to committed dose rate of I-131. If you want an accurate assessment of the activity in the charcoal cartridge, you should take it to the Chemistry Lab. The Liquid Plumbers will do a radio-nuclide analysis on their gamma spectrometer and then quote you the correct committed dose rate for the radio-iodines in the air sample. They should be able to give you an answer within 10 to 15 minutes. But then everybody should believe in something.

If you need to take a radioiodine sample in an atmosphere that you suspect contains noble gases, you can use this neat trick:

Take your sample, remove the Spot Sampler to a clean area, and run it for five minutes or so. This will purge all the noble gases out of the filters. After that, you'll get a good count for radioiodine.

The respirator rules are exactly the same as those given on page 283.

TRITIUM

As you must know by now, tritium emits only beta particles of very low energy. These beta particles cannot even penetrate the outer dead layer of the skin, and tritium is therefore an internal hazard only. When it is in the form of TDO or THO vapour, it can readily enter the body by inhalation or absorption through the skin. Uptakes of tritium via inhalation and skin absorption will be in the ratio of about 2 to 1.

Tritium enters the body fluids where it exchanges with ordinary water. The physical half-life of tritium is 12.3 years, and its effective half-life in the body is about 10 days. Although it is rarely done or necessary, the effective half-life (and hence the committed dose) can be reduced by increasing the rate of water intake. Beer works just as well.

Tritium is the major radiation hazard in the station. In Chapter 8, page 247, we said, "Air that is saturated with moderator water at 35°C can give 3,000 mSv/h of tritium to an unprotected worker (see Fig. 8.3). *That is 50 mSv per minute*". The PHT hazards are lower. Tritium levels in rooms containing PHT systems can reach 2 - 3 mSv/h immediately after D₂O spills.

MEASUREMENT OF TRITIUM

The measurement of tritium is difficult because the energy of the beta particles is too low for them to be able to penetrate the walls of any detector. Therefore, any instrument for tritium-in-air measurements has to be designed to draw the air right into the detector.

We have a permanently installed system for monitoring tritium concentrations in various areas. It is the **Alarming Area Tritium Monitor** or **AATM**. We have two types of portable instruments, the **Portable Tritium-in-Air Monitor** and the **Bubbler**. The AATM system does for tritium what the AAGM system does for gamma, and the portable instruments measure the committed dose rate from tritium. We'll describe the AATM System first.

Alarming Area Tritium Monitor

As you might guess, the purpose of the AATM is to warn you of sudden increases in ambient tritium levels. It does the same thing for tritium that the AAGM system does for gamma, except that we haven't yet managed to interface it with the Control Room.

The detector unit has two ion chambers. The sampled air flows through one chamber to produce an ionisation current from the tritium beta decay occurring in the chamber, and from gamma photons interacting in the chamber. The second chamber is sealed and produces an ionisation current only from gamma interactions in that chamber. The two currents are subtracted to give a net current due to tritium only.

The gamma background subtract feature is better than in the portable Tritium-in-Air Monitor (see page 134), because the chambers are bigger. But still, we can only install them in low gamma background areas.

We have two types of AATM; with and without *noble gas compensation*. Noble gases will give very high (false) readings, because their beta particles have much more energy than the tritium beta particles. AATMs that serve the Reactor Building have noble gas compensation. In this case the air flow is designed to pass through the first chamber, then through a dryer to extract the tritium, and finally through the second chamber. The first chamber measures tritium + noble gases + gamma; the second chamber measures noble gases + gamma. The difference in the two ionisation currents is due to tritium alone.

The AATM system is very similar to the AAGM system described on page 197. The four major components are:

1. *Tritium Monitor/Control Unit (RT) in the room being monitored.*
This unit contains the ion chambers, sample pump, flowmeter, electronics, alarm lamps, and a digital meter reading from 0 – 20,000 $\mu\text{Sv/h}$.
2. *Radiation Indicator (RI) outside each door of the room being monitored.*
The RI has a digital display of 0 – 20,000 $\mu\text{Sv/h}$, a red HIGH ALARM lamp, and a NORMAL green lamp to indicate correct operation.

3. *Radiation Annunciator (RA) inside the room being monitored.*
A horn and red strobe lamp indicate HIGH ALARM, and a bell and amber strobe indicate MALFUNCTION ALARM. There is also a switch to select ARM or MUTE. When you select MUTE, it silences the bell or horn, but not the visual alarms.
4. *Sample Panel*
The Sample Panel consisting of up to six sample-input lines and the necessary valving, pressure regulators, and flowmeters.

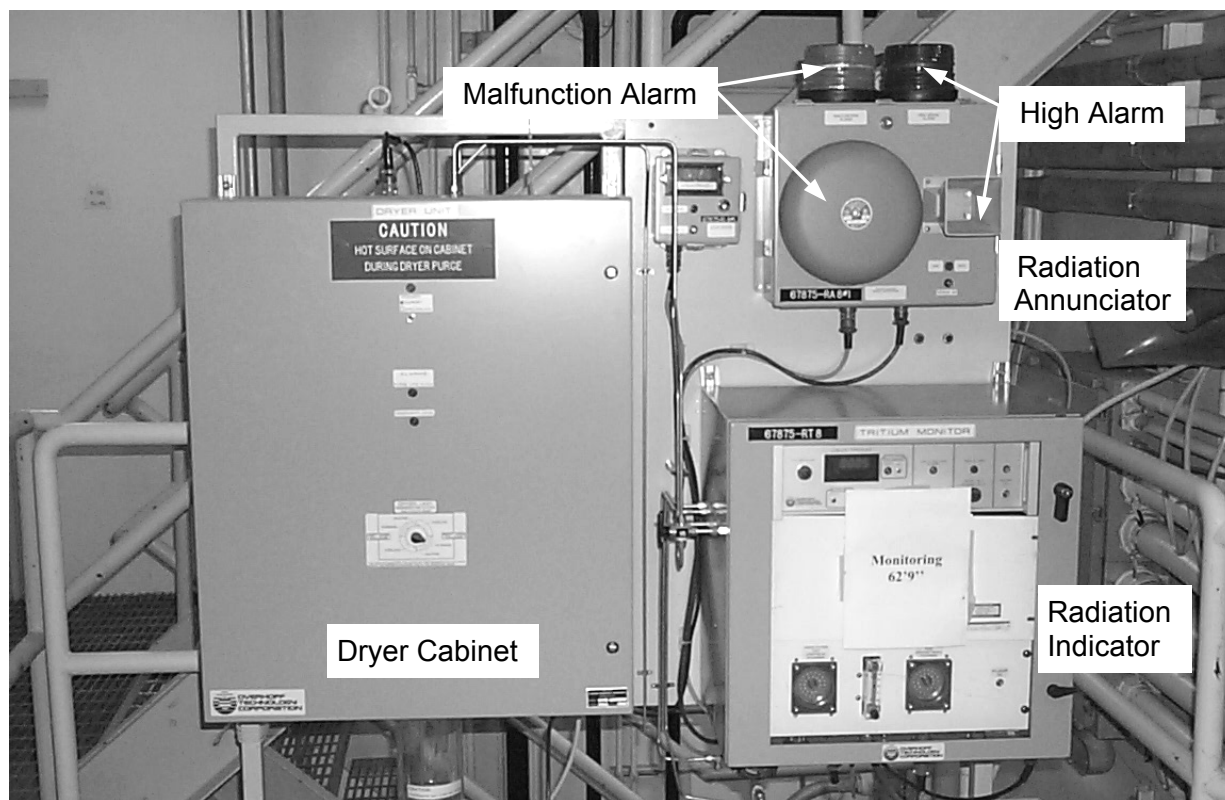

*Fig. 9.13. AATM with Dryer for Noble Gas Compensation
(This one is in the R/B monitoring the East Stairwell at 62'9" elevation.)*

Actions you must take if an AATM alarms

The HIGH ALARM set-points are set by Health Physics and posted on the RT. Typically, the alarm set-point will be 25 $\mu\text{Sv/h}$ in the Service Building, and 50 $\mu\text{Sv/h}$ in the Reactor Building. The actions you take for a HIGH ALARM are very similar to those for the AAGM:

1. Leave the area immediately.
2. Make sure that everyone else has left.
3. Inform the Control Room.
4. Do not re-enter the room until your uptake has been determined by Health Physics.
5. Silence the horn with the MUTE button on the RA.
6. Signpost the entrances of the area to warn others.

If the MALFUNCTION ALARM comes in:

1. Leave the area immediately.
2. Inform the Control Room.
3. Use a portable Tritium Monitor to measure tritium levels in the area.
4. Silence the bell with the MUTE button on the RA.
5. If you must work in this area, take routine bubbler samples and frequent measurements with the Scintrex Portable Tritium Monitor (see below).

Portable Tritium-in-Air Monitor

This was described on page 134 and shown in Fig. 6.6. It works on exactly the same principle as the AATM without noble gas compensation.

A Canadian company called *Scintrex* makes our Tritium Monitors. So people usually refer to this instrument as a “Scintrex”. Who are we to be different?

The Scintrex only works well if the gamma background is negligible. If it isn't, you'll get weird readings (like “– 01.5”). But you can use one of two tricks to get around this problem, namely you take a “grab sample” or a “remote sample”.

As mentioned on page 135, this instrument is sensitive to noble gases as well as tritium. A drawback, but we have taken advantage of it to locate noble gas leaks from the PHT system.

Although the Scintrex has a supposed range of 0.1 to 200 mSv/h, it is really a high-range instrument. It is not very reliable in tritium levels below 1 mSv/h.

The Scintrex does respond well to sudden large increases in the tritium level, such as you might get from a D₂O leak or spill in the area.

If you need an accurate measurement of low levels of tritium, you must use a Tritium Bubbler.

This isn't as convenient as a Scintrex —just goes to show that, like most other things, the quality of the result depends on the effort you put in.

Grab Sampling:

1. *Switch the pump on and place the Scintrex in the area you want to monitor.*
2. *Leave the area, and let the pump run for about a minute or so. Then come back and switch the pump off.*
3. *Go to an area with a low gamma background, switch the display on and note the reading. The Scintrex will read the tritiated air trapped in the chamber without background interference.*

Remote Sampling:

1. *Connect the necessary length of ¼” I.D. Tygon tubing to the pump inlet of the Scintrex, and run the other end of the tubing into the room/area you want to monitor.*
2. *Turn the pump on, allow a couple of minutes to purge, and observe the reading.*

Tritium Bubbler

The bubbler method is simple, accurate and not affected by gamma background or noble gases at all. The technique consists of bubbling tritiated air through clean water, which will trap the tritiated water vapour, and then analysing the tritium content of the water. One of our bubblers is shown below. It consists of a pump, a timer, a flow gauge and a removable water jar containing 100 mL of clean water. When you plug the bubbler cord into a 110 V outlet, the pump bubbles the sample air through the water. You adjust the flow to 1 L/min, and after 5 minutes the timer automatically shuts the pump off.

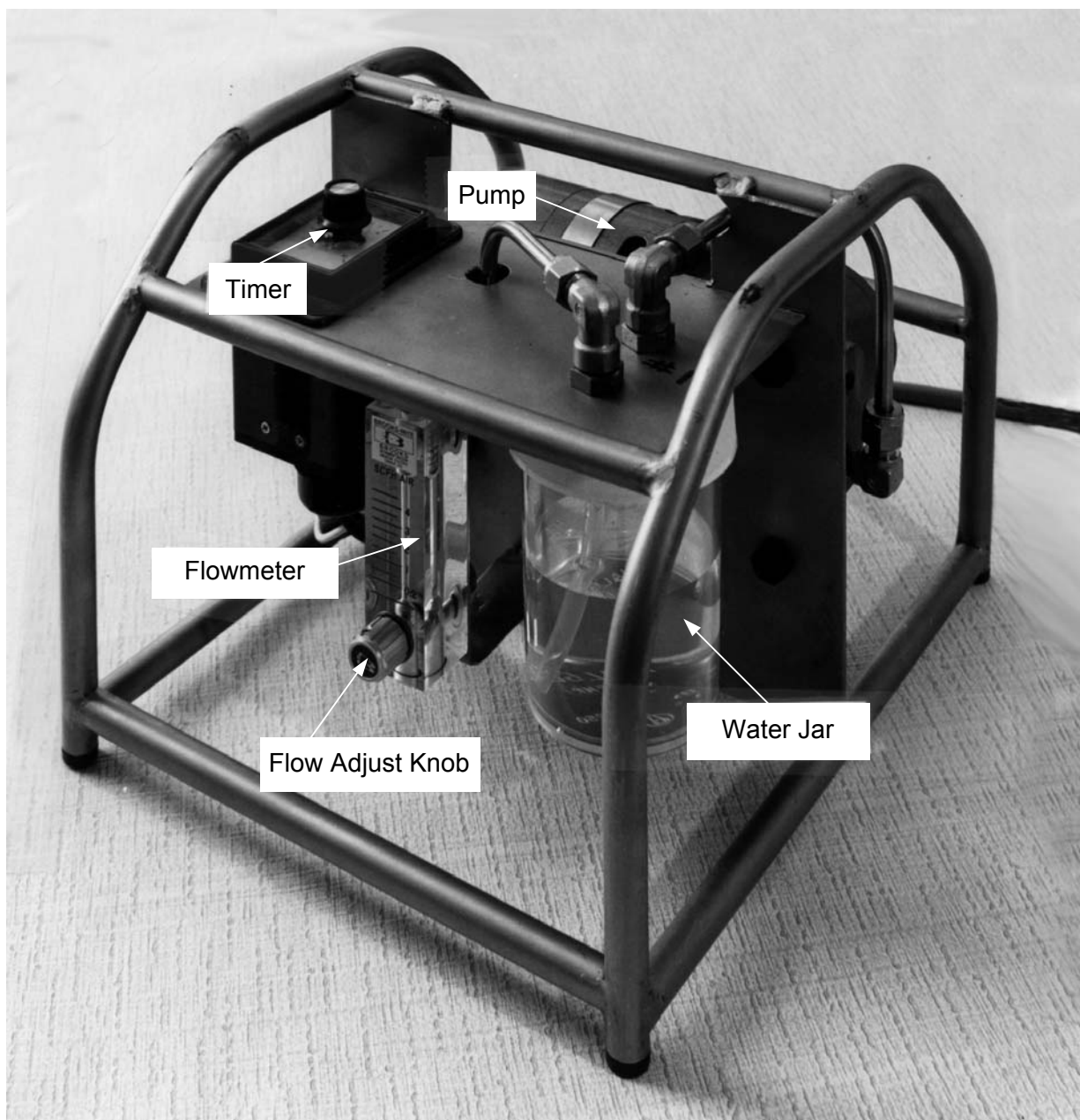

Fig. 9.14. Tritium Bubbler

The tritiated water vapour that was contained in the 5 L of air is now trapped in the 100 mL of water. You take the sample to the Chemistry Lab, where you analyse the tritium content of the water with a Liquid Scintillation Counter (LSC).

In our Applications Course, you will learn how to prepare a bubbler sample for counting in the LSC, and how to use the counter to get the results in $\mu\text{Sv/h}$. Again, to save wear and tear on your brain cells, a graph relating cpm on the LSC to the committed dose-rate from tritium is posted near the LSC.

If you are taking several samples, you must make sure that you use a clean jar each time. You pick up these jars (pre-filled to 100 mL) from any PESL.

And don't stand around in high radiation fields or high tritium levels waiting for the bubbler to finish. That's the timer's job.

If you find tritium levels above $10 \mu\text{Sv}$, you have to signpost the area. Now is a good time to review pages 204 to 206, because I'm going to have a cup of coffee instead of writing it all down again.

CONTAMINATION CONTROL

Contamination may be spread from one area to another by various means. For example, if you are working in a contaminated area, it is quite easy for you to track loose contamination from your clothing, shoes and tools all over the place. This is obviously bad, and to prevent it, various methods of contamination control have been developed. They are all based on one principle, namely **containment**. Whenever contamination is discovered, the important things are to contain it and then clean it up. The rest of this chapter is devoted to containment and cleanup.

ZONING

Zoning is the classification of an area according to its potential for a contamination hazard. In a good station design, the geographical layout of the zones is kept simple to minimise the number of zone interchanges, and hence the amount of traffic between zones. The purpose of zoning is to help prevent the spread of contamination. We have tried to set the rules for movement between zones to give us the maximum flexibility for work while minimising the chances of spreading contamination.

For the Techies amongst you, here is how you relate cpm from the LSC to $\mu\text{Sv/h}$ of tritium in the air sampled by the bubbler.

Assume that you used a bubbler to sample air containing 1 DAC of tritium.

$$1 \text{ DAC} = 3\text{E}5 \text{ Bq/m}^3 = 300 \text{ Bq/L} \quad (1000 \text{ L} = 1 \text{ m}^3)$$

5 L of sample air contains $5 \text{ L} \times 300 \text{ Bq/L} = 1500 \text{ Bq}$. These 1500 Bq are now in the 100 mL of water, i.e., the concentration in the water is 15 Bq/mL . You mix one mL of this water with 10 mL of liquid scintillator fluid and count it for one minute.

If the LSC were 100% efficient, it would indicate 15 counts per second or 900 cpm. Actually, its efficiency is approximately 40%, so it would read $0.40 \times 900 \text{ cpm} = 360 \text{ cpm}$. In other words, with this technique, 360 cpm in the LSC corresponds to $10 \mu\text{Sv/h}$ of airborne tritium.

At Point Lepreau we have three zones:

- Zone 3:** These areas contain radioactive systems and materials that may cause contamination. Examples of Zone 3 areas are the entire Reactor Building, Upgrader Tower, Service Building Basement, Decontamination Centre, Fuel Handling Maintenance Shop, Chemistry Lab, Spent Fuel Bays, areas containing SFB Ventilation, R/B Ventilation, and D₂O Vapour Recovery Rooms,
- Zone 2:** These areas contain no radioactive systems, and are normally free of contamination. They have the potential for contamination as a result of people traffic and ventilation flows. Examples of Zone 2 areas are the entire Turbine Building, the remainder of the Service Building, the Solid Radwaste Management Facility and the Spent Fuel Dry Storage Facility, and the Mechanical Office Complex.
- Zone 1:** A clean zone where absolutely no contamination is permitted. It is comparatively isolated from other zones so that work in Zone 1 doesn't require any knowledge of radiation protection at all. No Radiation Area Clothing is allowed in Zone 1. Examples are the Admin Building, STOIC Building, Construction Stores, and all yard areas inside the inner security fence.

At Point Lepreau, Zone 2 areas have blue walls, and all Zone 3 areas in the Service Building have green walls. The Reactor Building is painted with a special paint that only comes in white. But since the entire R/B is Zone 3, you shouldn't have any trouble remembering which zone you are in. The zoning layout is shown on pages 292 and 293.

When you move from Zone 3 to Zone 2, or Zone 2 to Zone 1, **you must monitor at the zone boundaries.** Hand & Shoe Monitors are provided at the high traffic boundaries and friskers at the rest. A contamination check takes only seconds, but a cleanup job of contamination you have tracked around may take you hours. All equipment that is taken into Zone 1 has to be monitored and be free of contamination.

Since Zones 2 and 3 may contain loose contamination, no food or drink is allowed in these areas (this includes candy, soft drinks, etc.). This means you must leave your lunch in Zone 1, and return there to eat it. The only exception to this policy is that coffee and other beverages may be obtained and consumed in the controlled coffee areas in Zone 2. The purpose of these restrictions is to prevent the ingestion of contamination. There are other habits that could cause contamination to enter your body (e.g., chewing your fingernails, picking your nose, etc.). But these habits could shorten your fingers or make your head cave in, so be nice to yourself.

Unzoned Areas

What's this? Well, there are some areas of the site that would have caused a lot of grief if we had designated them to be Zone 1 or Zone 2. So they are called **Unzoned Areas**. Some examples of these areas are the DU Warehouse, Service Maintenance Shop, Chlorine Building, CCW Pump-house, High Pressure ECC Building, Secondary Control Room, Switchyard, and all yard areas inside the inner security fence.

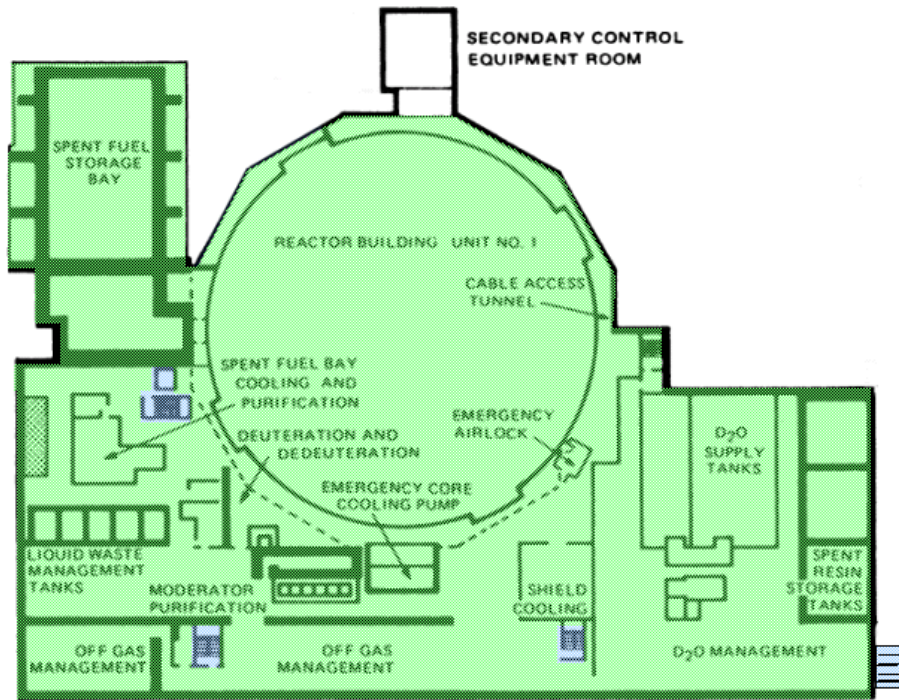

Elevation 25 ft = 7.6 m

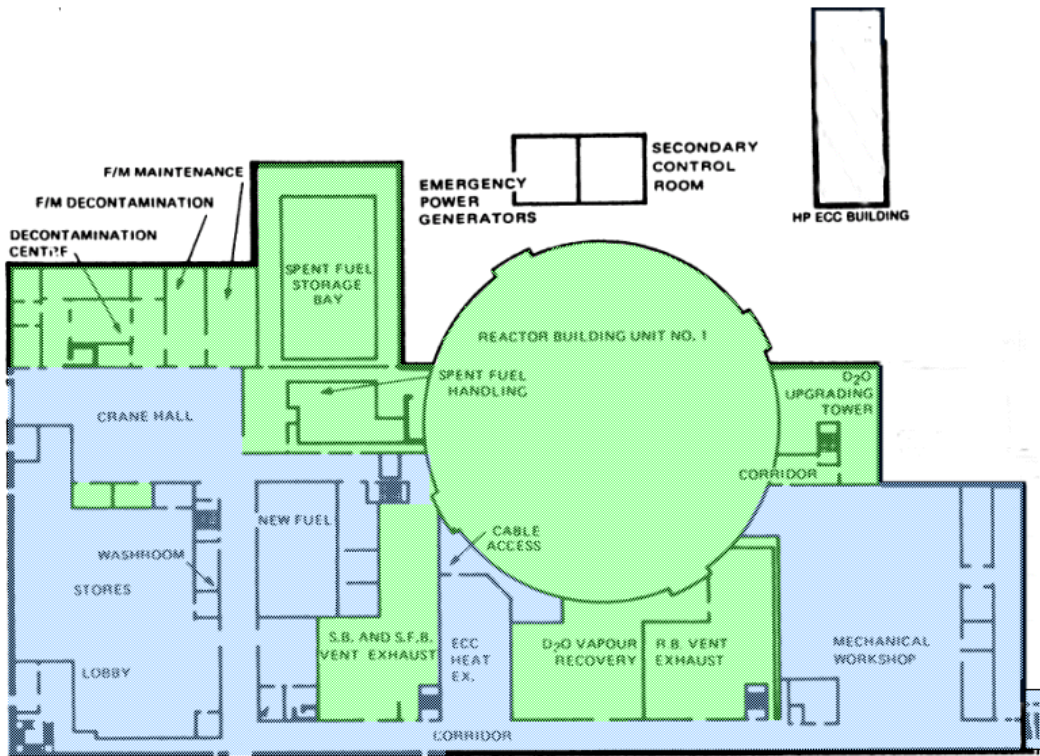

Elevation 45 ft 13.7 m

Unzoned

Zone 2

Zone 3

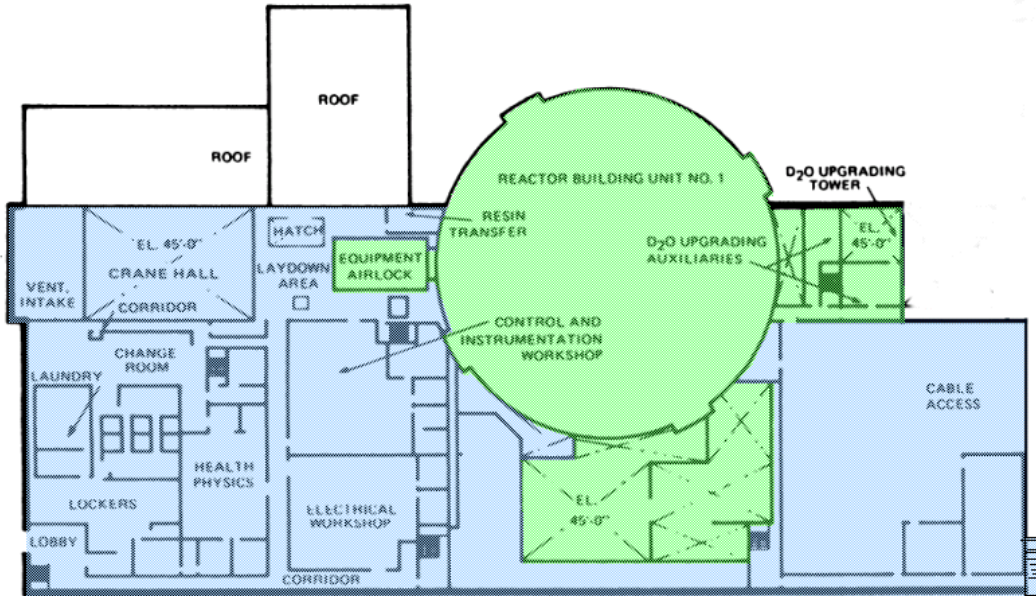

Elevation 62'9" = 19.1 m

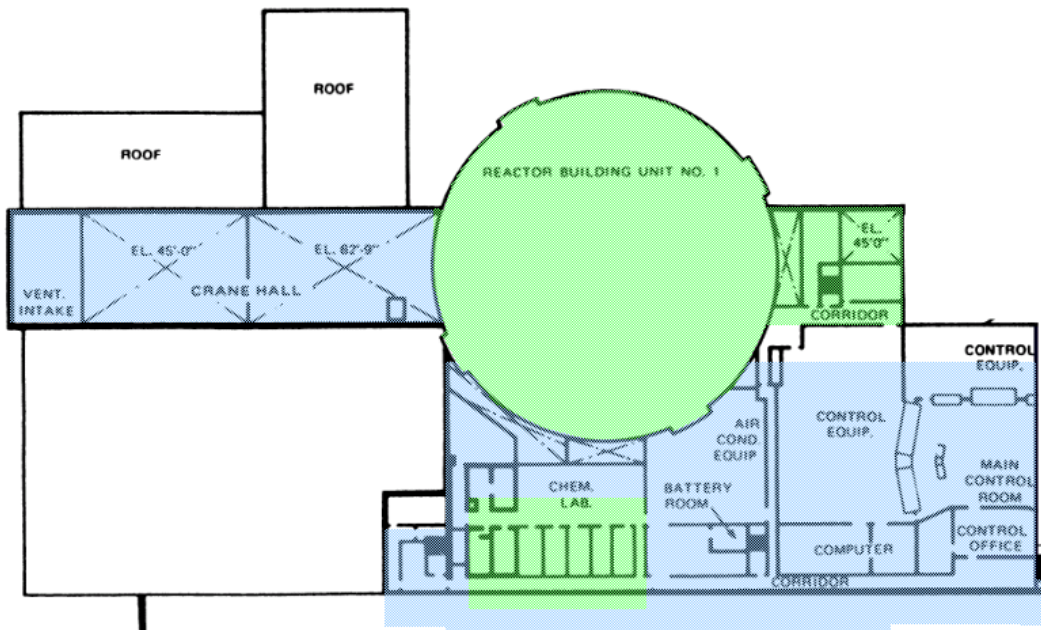

Elevation 75 ft = 22.6 m

Fig. 9.15. Zoning Layout at Point Lepreau

Basically, you will be doing it right if you consider Unzoned Areas as Zone 1 areas in which you are allowed to wear **clean** Radiation Area Clothing (Browns). If you are in Browns, you can wear them to all Unzoned Areas provided you monitor yourself (and any equipment you are taking with you) and find no contamination. You can leave via any ground level exit in the Service or Turbine Buildings, or through tunnels. Monitors are at or near these exits.

There is one exception to this policy: the Hanson Stream Pumphouse. It is considered a Zone 1 area, because it is off-site. To go there, you need street clothes.

The Solid Radwaste Management Facility (SRWMF), although situated outside the station security fence, is a Zone 2 area. It has its own security fence. Clean Radiation Area Clothing may be worn to the SRWMF. When one of the structures in the SRWMF is open, the inside of that structure is considered to be Zone 3. You must monitor before leaving the area, and extra monitoring should be done inside to ensure that contamination is not spread around. No loose contamination is permitted. You have to wear your TLD badge at all times in the SRWMF.

The same applies to the Dry Fuel Storage Canister Site. It is adjacent to the SRWMF and also has its own security fence. All areas inside the fence are Zone 2.

RELEASE PERMITS

The purpose of Release Permits is to document that all necessary contamination checks have been made on material released from the station. We have two types of Release Permit, **Unconditional** and **Conditional**.

Unconditional Release Permit

This is used to document that appropriate contamination checks were done on material or equipment removed from the station by unqualified people (i.e., those with Red or Orange badges).

Conditional Release Permit

This is used to alert Health Physics that material leaving Zone 2 or an Unzoned Area

1. is radioactive (i.e., activated or has fixed contamination),
2. or is suspected of being internally contaminated,
3. or originally came from or was used in Zone 3.

What Are the Rules?

Any material or equipment that is going to be moved from Zone 2 to Zone 1 or Unzoned Areas must be monitored for contamination. If you are Yellow or Green qualified, you do this yourself. If you find no contamination, you can proceed and you don't need a permit of any kind. If you are Orange or Red, you must get a Yellow or Green person to do the monitoring for you. In this

STEP	OPERATION
8	If Radioactive Material Shipping Documents are required, the Security Guard will check that the carrier has them in his or her possession.
9	The guards will perform contamination checks on a random basis or when instructed to do so by Health Physics. The Security Guard will ensure that an Unconditional Release Permit signed by a Green or Yellow qualified person accompanies all material transferred by Red or Orange qualified persons, and that a Conditional Release Permit has been signed by the Radiation Control Supervisor, a Health Physicist, or a person authorized by the Senior Health Physicist.
10	The Security Guard will complete the "Security" section of the Release Permit and route it as indicated on the form.
<p>NOTES:</p> <p>(1) The Chemistry Department shall approve the release of all liquid wastes before they exit the inner security fence. This is in addition to Health Physics approval of liquids containing any detectable activity.</p> <p>(2) Vehicles which have been used by persons in Browns and sent off-site (i.e., repairs) or returning to the pool outside the inner security fence must be frisked for contamination (cab interior) before being returned. The Yellow or Green qualified person who carries out the contamination check of the vehicle must complete an Unconditional Release Permit and give it to Security.</p> <p>(3) The tires of all vehicles must be checked for contamination before leaving the Service Building and Turbine Building.</p> <p>(4) Hand tools (not power tools) that have been used in Zone 3 and are transferred to Zone 1, unzoned areas, or the Hanson Stream Pumphouse must be individually frisked by a Green or Yellow qualified person and declared activity free prior to transfer (0 Bq/kg in the Clearance Monitor) and frisked before leaving Zone 2. Orange qualified individuals will require an Unconditional Release Permit.</p>	

Fig. 9.16. Procedure DP-6: Use of Release Permits

STEP	OPERATION
1	Yellow or Green qualified personnel who have to transfer material from within the SRWMF or station inner security fence to Zone 1 or unzoned areas outside the inner security fence, must make a direct contamination measurement of the material in a low background area. If the person transferring the material to Zone 1 or unzoned areas is unqualified (i.e., Red or Orange Badge), then he or she must ensure that a Yellow or Green qualified person does the contamination checks and completes an Unconditional Release Permit.
2	If the qualified person (Yellow or Green) detects any measurable activity on the material, then he or she must determine whether it is fixed or loose, i.e., take some smears. If the contamination is loose, then the material must be decontaminated. If the contamination is fixed or the material has been in Zone 3, proceed to step 6.
3	From the use of the material in the station, the qualified person should determine the likelihood of hidden internal contamination (including tritium which cannot be detected by a frisker). If it is possible that the material may be internally contaminated, go to step 6.
4	If the material to be transferred is in liquid form and its exact origin unknown, the liquid must be analyzed for radioactivity in the Chemistry Lab before it can be released from the station. If the liquid contains radioactivity, go to step 6.
5	If the material is contamination free it may now be released from the station. No paperwork is required (other than pass out slips, if necessary) providing that the person transferring the material off-site is Yellow or Green qualified. However, in the case of an unqualified person transferring the material, an Unconditional Release Permit signed by the Yellow/Green individual doing the contamination checks is mandatory.
6	Material that is activated, has fixed surface contamination, is suspected of containing internal contamination or has been used in Zone 3 must be released under a Conditional Release Permit.
7	If the material is being sent off-site, give the permit to the vehicle driver to hand to the Security Guard at the gate. If you are carrying the item out, hand the permit to the guard yourself. If the material is only being transferred to Zone 1, send the permit to Security.

case, an Unconditional Release Permit signed by that person must accompany the material being transferred. Even then, this only applies to material that isn't expected to be contaminated externally or internally (i.e., it hasn't been in Zone 3 or used in an active system). The completed permits are given to Security.

If the material is known or suspected of being contaminated, or has been in Zone 3, you need a Conditional Release Permit. This is signed by a Health Physicist, the Radiation Control Supervisor, or any person authorised by the Senior Health Physicist. Samples taken from the SRWMF for analysis in the station don't need a Conditional Release Permit if they enter the station via Security Gate #2 (the truck gate). We consider this to be a Zone 2 to Zone 2 transfer.

Orange people can monitor such things as stationery, mail, and personal items like clothing and purses. If they detect contamination, they must obtain help from a Green or Yellow person.

The entire story is given in Radiation Protection Procedure DP-6, reproduced here on page 295. The correct use of Release Permits is important. Please use DP-6 to make sure that you can do the problems at the end of this chapter.

RUBBER AREAS

Whenever loose contamination cannot be cleaned up right away, or when work activity is expected to generate loose contamination, a **Rubber Area** should be set up. Its purpose is to confine loose contamination.

You set up a Rubber Area by roping off the area and covering the floor with a temporary surface. We use a special canvas, which retains loose contamination very well. Access is allowed at only one entry point, where a **Rubber Station** is established. This consists of a step-over barrier and storage racks for clean and used shoe covers, gloves and disposable coveralls. Fig. 9.17 shows a rubber station at the entrance to a Rubber Area.

We have two types of shoe covers: rubber overshoes (called **rubbers**) and booties. Both types can be used in Rubber Areas to make a fashion statement. Rubbers are useful in wet locations. Shoe covers are washed in the Zone 3 laundry and re-used.

Movement across a rubber station must be carried out with great care to avoid spreading contamination. The detailed procedures will be taught in the Applications course — for the time being, it is sufficient to say that shoe covers must be removed in such a way that no contamination reaches the clean side of the barrier. You must monitor yourself for contamination after crossing the barrier.

Because of the high probability of contamination, everyone must wear protective clothing within a Rubber Area, i.e., Browns as a minimum and often disposable coveralls as well. A Rubber Area is only intended to be a **temporary** extension of the zoning system. Once it has served its purpose, the Rubber Area should be decontaminated and the rubber station equipment removed. You are not allowed to enter a Rubber Area in unprotected street clothing.



Fig. 9.17. Rubber Station at Entrance to Rubber Area

RUBBER CHANGE AREA

If the level of loose contamination in a Rubber Area exceeds 20 CCL (300 cps on a smear), you should set up a **Rubber Change Area (RCA)**. This is a Rubber Area inside a Rubber Area. An RCA **must** be set up for more than 70 CCL of loose contamination (1000 cps on a pancake frisker; this is the top of its range).

To enter an RCA, you would normally wear disposable coveralls over your Browns. You need two sets of footwear, so that you can take one pair off when returning to the Rubber Area. The best way to do this is to wear rubbers over Tyvek booties when entering the RCA, because then it is relatively easy to remove the rubbers. If you wear two sets of rubbers, you are a masochist.

You also need two pairs of gloves. The smart thing to do is to use cotton gloves under rubber gloves. This gives you good protection, reduces sweating of your hands, and makes it easy to change the outer rubber gloves. You should change gloves often because if they have picked up contamination, you avoid high extremity exposure, and you will also reduce the chances of cross-contamination.

When you leave the RCA, you remove the disposable coveralls, outer pair of gloves, and rubbers. You then go to the Rubber Area exit, where you remove the booties and the second pair of gloves. You will learn how to do all this in the Applications course.

CHANGE ROOMS

It is our policy to provide a complete change of clothing for everyone who routinely works in Zones 2 and 3. If you are entering Zone 3 for inspection purposes, it is up to you whether you wear protective clothing or not. It is there if you want it. Generally, I would recommend it, because NB Power will not compensate you for contaminated personal clothing.

The purposes of a change room are:

1. To store and separate street clothes from the work clothes worn in Zones 2 and 3 (i.e., we want to separate clean clothes from potentially contaminated clothes).
2. To provide separate "clean" and "active" dressing areas.
3. To provide showers, for cleanliness and decontamination.
4. To provide contamination monitoring facilities.

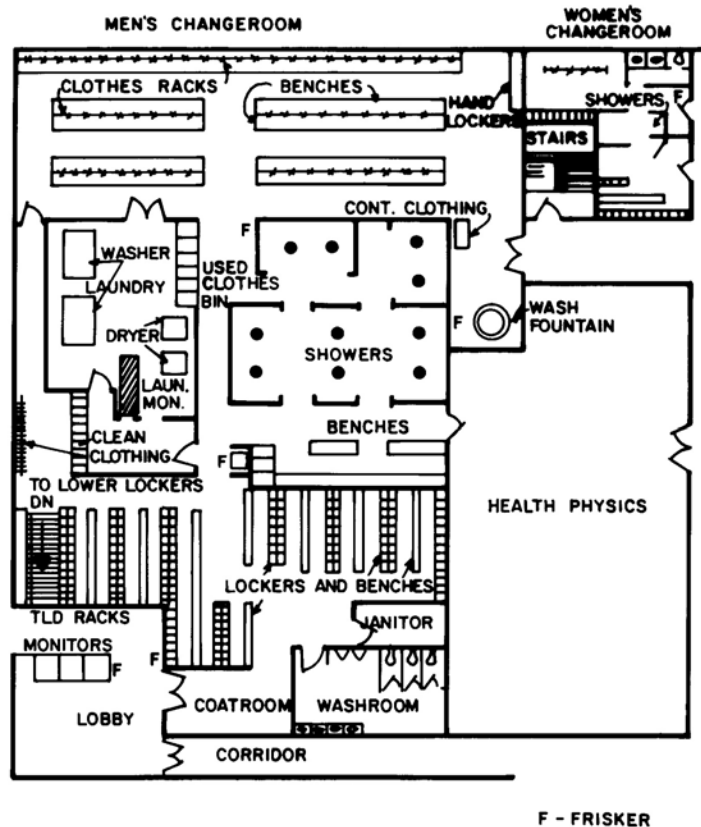

Fig. 9.18. Change Room Layout at Point Lepreau

WHAT YOU DO IF YOU ARE CONTAMINATED

It happens to the best of us. Perhaps someone carelessly contaminated a handrail while wearing gloves, and you later touched the rail with your bare hands: at the interzonal monitor, lights flash and buzzers buzz. Or perhaps your shoes picked up some contamination that happened to be lying on the floor you walked over. Well, what now?

Remember the following procedure and use common sense:

- (a) before you do anything else, contain the contamination by putting on disposable booties or cotton gloves (available at all interzonal monitors).
- (b) inform the Work Control Area.
- (c)

you must decontaminate yourself —
— but without spreading contamination on your way to the Change Room (for hands) or the Decontamination Centre (for boots).

- (d) a contamination survey must be done to find the location and extent of the contamination.
- (e) the contaminated area must be isolated to prevent uncontrolled traffic through it.
- (f) the contaminated area must be cleaned up.



Fig. 9.19. The Men's Change Room

VENTILATION SYSTEMS

So far we have described how we minimise the spread of contamination by applying procedural controls. The design of the station also plays an important role, particularly the design of the ventilation systems.

In a conventional plant (i.e., non-nuclear), the ventilation system provides acceptably fresh air to people in the plant and is often used for heating and cooling. In addition to this, the ventilation system in a nuclear plant also has to do the following:

- 1) supply clean, uncontaminated air to people in the station,
- 2) prevent the spread of contamination throughout the plant,
- 3) clean up the air in a room or enclosure after it has been contaminated.

It is not essential for you to know how the ventilation systems at Point Lepreau work, but

**It is vital that you keep all doors shut,
or the systems won't work as intended.**

We have had several licence violations related to this very issue. For the keen types amongst you, I have put the design aspects of the ventilation systems in the Techie boxes in the next three pages.

CLOSED CYCLE VENTILATION

One method, which prevents spreading of airborne contamination and at the same time also supplies clean air for station staff, is to have separate ventilation systems for clean (i.e., contamination-free) and dirty areas. This approach is used in the Service Building at Point Lepreau; the ventilation system for the Control Room, for instance, is entirely separate from that used for the Spent Fuel Storage Bay.

Care must be taken in the design and operation of these systems to ensure that air does not flow or leak from a closed contaminated area (such as the Spent Fuel Storage Bay) to adjacent areas. Running the contaminated area at a slightly lower atmospheric pressure than the surrounding area can do this. The usual method of achieving this is by adjusting ventilation dampers in such a way that more air is exhausted than is supplied through the intake. (The difference is made up by in-leakage through penetrations in the walls, such as doors, pipe runs, and cabling runs). If you keep the doors shut, the contaminated area will be at a slightly lower pressure than the rooms surrounding it.

The exhaust flow from contaminated areas is normally passed through air-cleaning units, whose design depends on what type of airborne contamination is expected.

PARALLEL VENTILATION

In parallel ventilation systems, a common source feeds each room with fresh air, which is then exhausted to a common stack.

During commissioning, the inlet and exhaust dampers in the ducts were adjusted to provide the proper air flow for each room. It is therefore very important not to play with these damper settings after the system has been set up. As before, the system cannot possibly operate correctly if doors access hatches and what have we are left open. Further more, the doors at Point Lepreau also perform the function of fire doors — but only if they are closed!

The designers tried to provide a greater airflow through those rooms (such as the Decontamination Centre) where there is a larger chance of airborne contamination. Such rooms might have a designed air flow of as much as four or five complete air changes per hour, whereas other rooms less likely to be contaminated might have less than one air change per hour.

A fairly high flow rate through a room will ensure that if airborne contamination has been released, it will not persist for too long. This of course assumes that the source of the contamination is removed. If it isn't, then even by having a very large number of air changes per hour won't do any good.

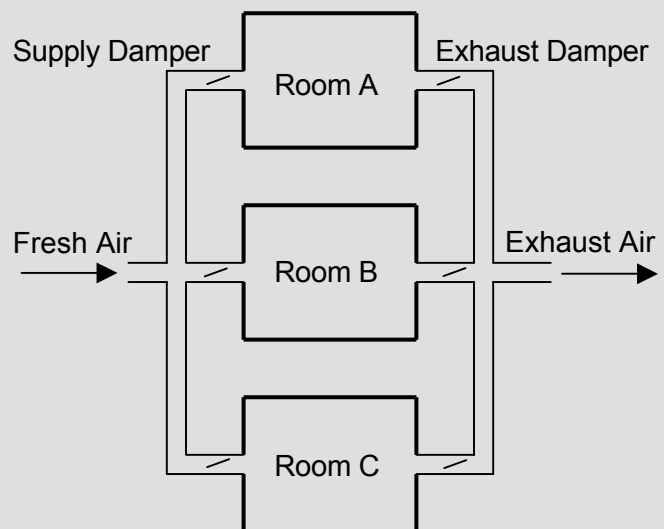

Fig. 9.20. Parallel Ventilation System

SERIES VENTILATION

The two types of ventilation design described above (quickly now, what were they?) provide excellent contamination control; however, in large plants it is very expensive to use these two principles only. Conditioned air exhausted from clean areas can be used to ventilate less clean (i.e., more likely to be contaminated) areas of the plant. This is the principle of ventilation used in the Reactor Building at Point Lepreau.

It is also used in the Service Building. For example, air flows from Room S-105 (Zone 2 corridor) to S-143 (Zone 3 Spent Fuel Bay Ventilation Exhaust Room), then via the central contaminated exhaust to the stack.

Again I can't emphasise too often that unless you keep the doors closed, such systems cannot work as intended. Indeed, it is not hard to imagine conditions caused by open doors or faulty damper settings that would result in air flowing from Zone 3 to Zone 2 rather than vice versa. Dampers are not to be adjusted without the Shift Supervisor's OK.

HEAVY WATER VAPOUR RECOVERY SYSTEMS

Heavy water costs a lot of money. At the time I write this, it costs about \$300/kg or 10 times as much as kitchen Scotch. (It used to be 16 times as much; thank your Provincial Government.) So, it is essential that heavy water vapour in the air be recovered rather than exhausted up the stack. Areas in the Reactor Building likely to contain D_2O vapour are not fed by the normal Reactor Building ventilation system, but instead have their own closed cycle system. The air exhausted from such rooms is passed through a dryer, which removes 90% or more of the water vapour before the air returns to the room.

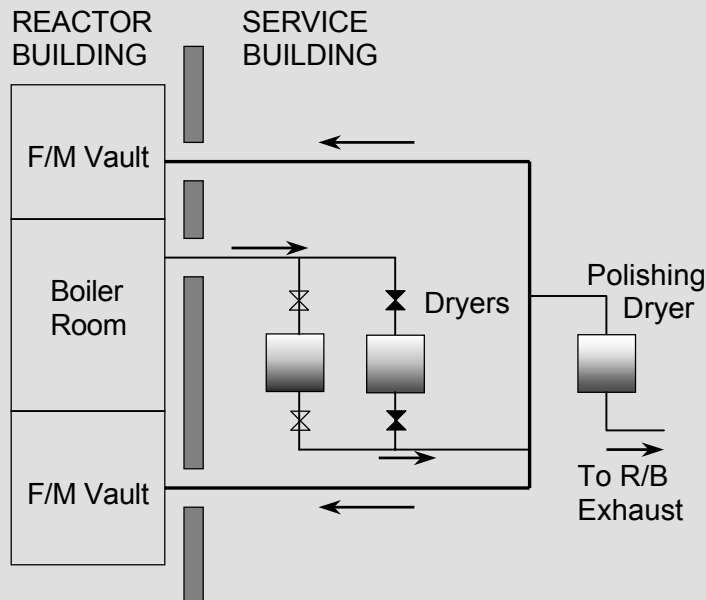

Fig. 9.21. D_2O Vapour Recovery System

Our dryers contain a material called molecular sieve (small cylindrical beads a few mm^3 in size), which traps water vapour in the air passed through the dryer. Before the sieve is saturated, it is regenerated by heating it. This drives off the trapped water vapour, which is blown through chillers to condense it. This condensed water is then fed to the D_2O collection system.

Figure 9.21 shows a simplified diagram of the D_2O vapour recovery system for the Boiler Room. Air from the Boiler Room passes through one dryer, while, at the same time, the other one is being regenerated. (Every several hours,

they reverse roles automatically). The small dryer shown is known as a "polishing" dryer. Its purpose is to exhaust a small flow from the system in order to hold the Boiler Room atmosphere at a slightly negative pressure compared to its surroundings. At the same time, it further dries this air to minimise D₂O losses and the quantity of tritium discharged to the environment via the stack. Apart from recovering heavy water in the air, dryers will reduce the ambient airborne tritium levels in the rooms they serve. For example, air at a dew point of -10°C holds only about 1/20th of the water vapour that air at a dew point of +30°C can hold. Consequently, the tritium level will be reduced in the same ratio.

Dryer systems installed to serve the heat transport system areas will ensure a quick and uniform spread of noble gas releases throughout all Reactor Building rooms served by them. However, they will absorb airborne particulates to some extent. When the dryers are opened up for maintenance, beware of airborne and surface contamination.

Local Ventilation Systems

These are used to prevent the spread of localised releases to the rest of the atmosphere. They can be provided by the building design or set up as needed, and are effective for D₂O sampling and handling areas, decontamination and some maintenance work.

Fume Hoods

Figure 9.22 shows a fume hood used for decontaminating small items. The front window can be raised to provide working space and to permit items to be moved to and from the fume hood. A fume hood normally has its own exhaust fan which draws air in through the opening at the front at a speed of 0.5 to 1 m/s.

Too low a flow may permit leakage out of the hood, and too high a flow blows all the crap around inside it. The exhaust flow from the hood is filtered and then passed to the main building exhaust.

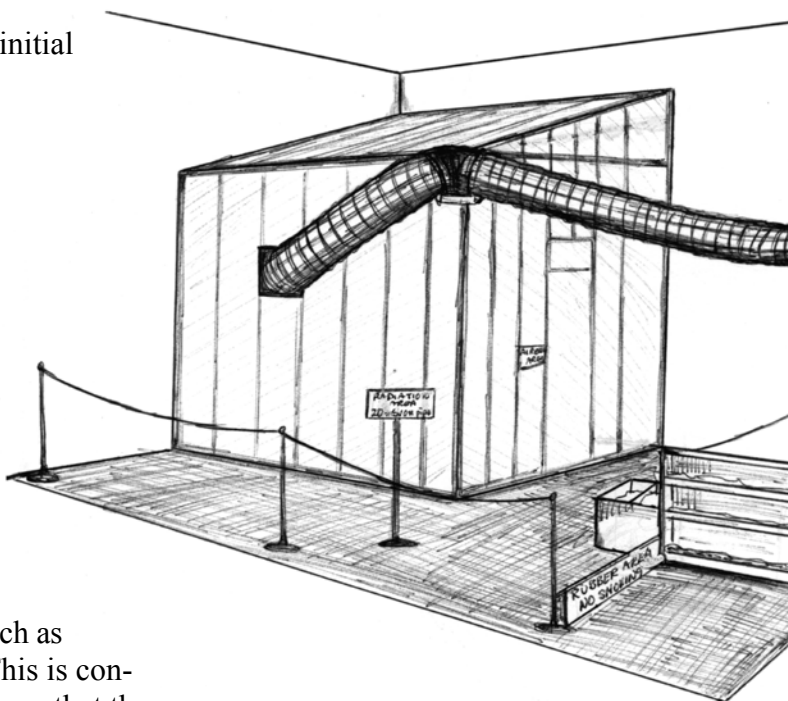

Fig. 9.22. Fume Hoods in the Decontamination Centre

Temporary Local Ventilation

Sometimes a contamination source arises that was not foreseen in the initial plant design. Or, we may not have wanted to install permanent local ventilation in areas where operations causing airborne contamination occur only rarely.

In these cases we often erect plastic tents at the site. There are many ways of doing this — one of them is shown here. (It's hard to take photos of transparent plastic sheeting, hence the drawing.)



Tents require an air exhaust duct such as "elephant trunking" shown here. This is connected to ventilation exhaust ducts, so that the suction is provided by the system exhaust fans. We also have a "super-sucker" to help the fans, because the ventilation exhaust flows are not as high as they should be.

Fig. 9.23. Temporary Plastic Tent

PROTECTIVE CLOTHING

Protective clothing provides the wearer protection from loose contamination, and limits the spread of contamination when the proper procedures are followed.

Protective clothing should be worn whenever work is done in an area where radioactive contamination may exist. Since the contamination can be found in many forms (loose particulates, liquids, and vapours), we have quite a variety of protective clothing. It ranges in complexity from ordinary coveralls to vapour-proof plastic suits that have their own air supply fed from breathing air headers located through out the station.

Active Area Clothing ("Browns")

As a daily routine, most workers in Zones 2 and 3 change from street clothing into active area work clothes. This is done in the Change Room (we've been there on page 298 and 299). Our active area clothing, known as "Browns", consists of brown cotton coveralls, under wear, socks and active area safety shoes. We also have blue flameproof coveralls for welders, and brown parkas and thermal underwear for winter use. No personal clothing at all is worn with Browns.

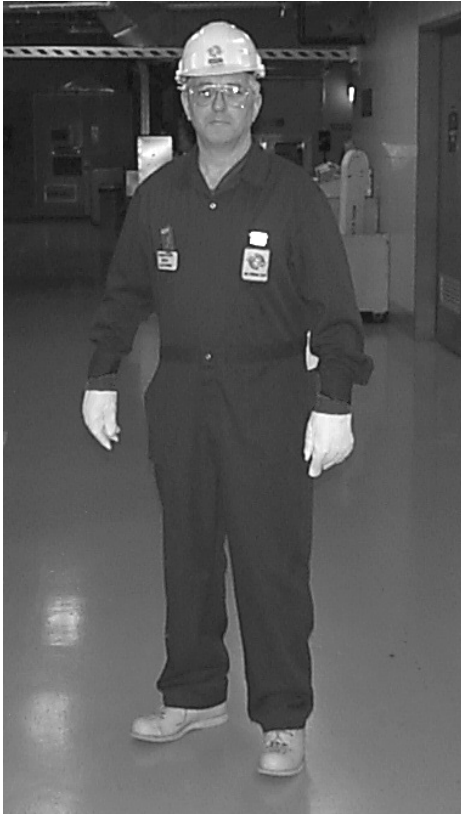

Fig. 9.24. Dressed in Browns

This picture shows a gentleman (well... actually it's Gerry) resplendently clad in Browns. For accessories, like all smart Radiation Workers, he has selected yellow underwear, yellow socks, active area safety shoes, TLD badge, PAD, safety glasses, and hard hat. Ladies wear the same, except that their physiological niceties have been recognised with more suitable underwear.

This clothing will protect most of your skin from contact with loose contamination. The spread of loose contamination via Browns is limited by confining this clothing to the site, and excluding it from Zone 1. In addition, you must remove any protective clothing worn with Browns before you leave the actual work location or Rubber Area where you are doing your thing.

When you return to the Change Room, if you suspect that your Browns may be contaminated, frisk them. If the clothing is contaminated, put it in the "contaminated" carts provided. If it is clean, hang it on the hooks assigned to you and reuse it for the rest of the shift. At the end of your shift, zip up the Browns, and put all the clothing into the appropriate bins for laundering. You are not allowed to mix active area underwear with your street clothes (i.e., during lunch breaks). This would defeat the purpose of keeping personal and active area clothing segregated.

Finally, running TLDs and PADs through the wash tends to ruin them, so please remove them from the Browns before you leave the Change Room.

If your hands are contaminated, you can scrub them in the wash fountain in the Change Room. If your shoes are contaminated, clean them in the Decontamination Centre. If any other part of you is contaminated, you must shower and use the frisker near the showers before dressing in your street clothes.

Lab Coats

Lab coats are provided to protect your street clothes from chemicals and other nasties. They shall not be used for protection against radioactive contamination. It is intended that lab coats be worn in the Chemistry Lab, Health Physics Lab, Stores, photocopier areas, etc. Brown lab coats are provided for areas inside the inner security fence. They shall not be worn in Zone 3, except for the Chemistry Lab. Green lab coats are available for use in Zone 1.

Disposable Coveralls

Disposable coveralls are shown in Fig. 9.25. They are generally known as *Dispos* (pronounced as "dispose"). They are used for extra protection against high levels of loose, dry contamination.

You wear Dispos over Browns in Rubber Areas or Rubber Change Areas if you expect high levels of contamination. Disposable booties may be worn with the coveralls but shoe covers (usually rubbers) shall be worn over the booties. In addition, disposable booties are provided at interzonal monitors to cover your shoes if they are contaminated. Take care when walking in disposable booties, as they are quite slippery.

Dispos shall not be used as a substitute for Browns. Occasionally, you must enter areas on very short notice, and you need protection for personal clothing. You can wear Dispos over personal clothing:

1. To protect clothes from radioactive contamination in a Rubber Area for brief inspections, not work,
2. To protect your clothes from a dirty environment like oil, grease, or insulation fines. (This non-standard use of Dispos needs the approval of the Radiation Control Supervisor or the Shiftie.)



Fig. 9.25. Dispos

Gloves

You must wear the right gloves when you work with contamination. We have quite a selection, ranging from cotton gloves to shielded gauntlets. The choice will depend on the work and the conditions.

Cotton Gloves are used for low levels of dry contamination. They are comfortable, your hands don't get clammy, and you get some beta shielding as well. We keep some at the interzonal monitors, so that you can contain contamination detected on your hands. We also have a slightly heavier-duty version treated with a light vinyl coating. Some people prefer them because they tend to fit better.

Rubber Gloves are for wet conditions and for use with plastic suits. They are ordinary household rubber gloves. Rubber gloves should be checked for defects before you put them on (one way of doing this is to slightly inflate them and then squeeze them to check that they don't leak). Used rubber gloves are laundered, tested, and put back in general service, but we always use new ones for plastic suits.

Surgical Rubber Gloves are worn for delicate work where a sense of touch is needed. You must be careful not to damage these thin gloves. Don't use them for grunt work.

Shielded Gauntlets loaded with lead are available from Stores for work in high beta fields.

Footwear

Safety shoes or boots with distinctive markings are worn with Browns. You will be issued your own Radiation Area safety shoes, which you will keep on your assigned rack in the Change Room.

In addition, we have rubbers, re-usable booties and disposable booties. Here are the standard items worn at Point Lepreau: from left to right you can see disposable booties, Radiation area safety shoes, and rubbers.



Fig. 9.26. Footwear

Plastic Suits

A plastic suit is not the latest fad for people with kinky sartorial requirements. It is a yellow PVC coverall worn with a hood and supplied with air to provide cooling and breathing air, as shown in Figure 9.27. Plastic suits are the only protective clothing suitable for use in tritiated atmospheres. Whenever we say plastic suit, we mean plastic suit plus disposable hood. This combination is also called "plastics". Plastics are also worn in areas with high levels of loose, airborne particulate or radioiodine contamination.

Tritium enters the body through inhalation and by absorption through the skin. If you wear a tritium respirator, you will protect yourself against inhalation, but do nothing about the skin absorption.

Booties are permanently attached to the suit. Gloves are attached by means of cuff rings; they can also be taped on. When you wear the suit with a disposable hood, you are completely isolated from the environment surrounding the suit.

The compressed breathing air supply maintains the suit at a positive pressure. Air is fed from air headers we have throughout the station via an airline to the suit. Within the suit, the air is distributed by a system of ducts to the head, trunk, arms, and legs, and exits down through the hood. The air provides breathing air, flushes out contamination that has penetrated the suit and keeps the wearer cool.

The airline supply also houses the wires needed to connect to the Plastic Suit Communication System. The earphones and the mike are attached to the hard hat, and the communications cable is connected to a receptacle inside the suit. You should wear the communication gear, because Control Room P.A. messages and emergency alarm signals are fed into it. You'll learn how to do all this in the Applications Course.

The degree of protection a plastic suit can provide in a tritium atmosphere is described by the **Protection Factor (PF)**. The PF is a measure of how much higher the tritium concentration is outside the suit compared to inside the suit. The PF for a plastic suit applies only to tritium:



Fig. 9.27. "Plastics"

$$PF = \frac{\text{Tritium Uptake without Protection}}{\text{Tritium Uptake with Protection}}$$

You can turn this expression around and say that

$$\text{Tritium Uptake with Protection} = \frac{\text{Tritium Uptake without Protection}}{PF}$$

As an example of the use of PFs, consider a situation where you must work for 2 hours in a tritiated atmosphere of 2 mSv/h.

If you wear no protection, your committed dose will be $2 \text{ mSv/h} \times 2 \text{ h} = 4 \text{ mSv}$.

If you wear plastics with a PF of 100, your committed dose will be $(2 \text{ mSv/h} \times 2 \text{ h})/100 = 0.04 \text{ mSv}$.

In other words, your committed dose is only 1/100th of what it would have been with no protection.

In this exercise, we assumed a PF of 100. This is the standard figure we use for dose estimates. The actual protection factor can vary quite a bit, depending on how the suit is used. If you're careful when undressing, you can do quite a bit better than 100.

Plastic suits are kept at the Protective Equipment Storage Locations (PESL). We have four sizes: Small, Medium, Large, and Jumbo. You'll discover by trial and error which fits you best. If in doubt, select the next larger size, because if you use a suit that is too small, you may tear the seams. As far as I know, only Wayne Avery wears the small size! The disposable hoods are all the same size. They are designed to attach to the special hard hats for suits, and they are also kept at the PESLs.

So what are the rules? You have to know this:

Plastics MUST be worn:

1. for airborne contamination $> 500 \mu\text{Sv/h}$,
2. for any work with Moderator D_2O ,
3. when recovering PHT D_2O spills $> 1 \text{ L}$ (about 1 m^2 on the floor),
4. for anticipated committed dose $> 500 \mu\text{Sv}$.

Plastics rely on an airline to provide breathing air. This means that PLASTICS SHALL NOT BE WORN IN IDLH*) ATMOSPHERES.

*) IDLH means "Immediately Dangerous to Life and Health". This rules out the use of plastics in Confined Spaces, chlorine atmospheres, and similar threatening environments.

Wearing the Suit:

- a) The suit must be worn with the hood, gloves and air supply.
- b) The hood is not to be removed at any time.
- c) The air supply is to be available and connected continuously from the time the tritiated atmosphere is entered until the area is vacated.
- d) If the suit is ripped, you lose protection. You should change the suit, or at least tape the rip if it is impractical to leave the area.

The single most important thing to remember whenever you wear an air-supplied plastic suit is to establish and maintain the air supply. You must not do anything that decreases the integrity of the suit. Do not lift the hood, work without gloves, cut, rip or otherwise change the suit. The air-supplied suit is a complete protection system. If you change the components or operating procedure, the system will not give the desired protection, and in many cases it will give you **no protection**.

Also available at the PESLs are large yellow rubber booties and blue plastic cover suits. They are used to protect the suit when you may come in contact with D_2O , or the nature of the work involves access to a confined work area that may cause abrasions to the suit (i.e., boiler primary head entry).

Protection factors as high as 1000 have been measured under ideal conditions. In practice, you should be able to achieve PFs of at least 100. The more careful you are, the higher the PF will be. Plastic suits are our best defence against tritium: if you are in doubt as to whether you should wear one or not, do the smart thing and wear it.

When a plastic suit has been worn in a contaminated area, take care not to spread any contamination that may have become attached to the suit. You may pick up a significant tritium exposure during the undressing procedure. Get out of your suit carefully but quickly, put the suit and airline in a plastic storage bag, and then check yourself for contamination. Leave the undressing area. You will practise dressing and undressing in the Applications course.

The plastic suit has been designed so that a safety harness can be worn under it. The D-ring of the harness is accessed through a back pocket of the suit, but you will need help to attach the safety lanyard to the D-ring.

Finally, you need to be aware of the conventional safety hazard of wearing plastics:

1. Work in hot areas may cause some symptoms of heat stress. We recommend a time limit of two hours for work above $25^{\circ}C$ – this time limit is mandatory above $30^{\circ}C$. A rest period of half an hour is necessary after two hours in plastics.
2. Be careful to avoid slipping and tripping, especially with air hoses all around you.
3. In plastics you have poor manoeuvrability and limited vision.

RESPIRATORY PROTECTION

During your work at Point Lepreau, you may have occasion to enter areas of airborne contamination. You must wear respiratory equipment for protection against high intakes of airborne contamination. The protective equipment we have available for your use is described below, as well as its limitations.

Respiratory protective devices vary in design, application, and the degree of protection they provide. As well as assessing the airborne hazard, you must know the limitations of the available equipment so that you can select the appropriate type for the conditions you have identified.

There are three types of respiratory protective devices at Point Lepreau. They are:

1. Air-Purifying Respirators

Air-purifying respirators provide a filtering action to the air as it is drawn through the device under lung power.

2. Air-Supplied Equipment

Air-supplied equipment is supplied with clean air from a separate source. The air source is the Breathing Air System.

3. Self-Contained Breathing Apparatus (SCBA)

Self-contained breathing apparatus is a type of air-supplied equipment. The difference is that the user carries his air supply around with him in the form of compressed-air cylinders strapped to his back.

Each of these classes has its advantages and disadvantages. Before you can choose which equipment to use, you must know the degree of protection each provides for the various airborne hazards.

Protection Factors

The Protection Factor (PF) of a respirator is a measure of the amount of protection it will provide against a specific hazard. It is defined as

$$PF = \frac{\text{Uptake without Respirator}}{\text{Uptake with Respirator}}$$

What's the difference between this definition and the one given on page 308 for plastics? The plastics PF applies to tritium only, but the respirator PF applies to any airborne hazard. A word of warning here. The PF of a particular respirator will not be the same for all the airborne hazards that you are likely to meet. For example, normal air-purifying respirators do not give any protection at all against tritium, although they are very effective against particulates.

Air-Purifying Respirators

Air-purifying respirators have been around ever since the days when the Romans used them in lead and gypsum mines. Of course, their design and efficiency have been improved enormously, but the basic concept has remained unchanged. (You needn't worry unless you find one with the expiry date written in Roman numerals.)

Air-purifying respirators, often called cartridge respirators, remove contaminants from inhaled air. This is done by mechanical filtration of particles as well as chemical removal of specific vapours and gases. The respirators used for radiation work at Point Lepreau contain a filter cartridge known as a TEDA(H) cartridge. It includes an absolute filter to remove particulates and an activated charcoal filter to remove radioiodine. Activated charcoal means charcoal impregnated with a chemical called TEDA*) to improve the removal efficiency for radioiodine.

Air-purifying respirators at Point Lepreau all operate in the negative pressure mode. This means that negative pressure is created inside the respirator when you inhale, and this causes the air to be sucked in through the filter cartridge. When air is inhaled, then, any defects in the mask or a poor seal to the face will allow contaminants to leak into the respirator.

The two types of respirator masks we have at Point Lepreau are **full-face** and **half-face**.

Figure 9.28 shows the full-face respirator. The mask is light, and has a full face-piece unit with an interchangeable inlet receptacle. It has a hairnet type head harness. With a suitable inlet connector, it can be used in all three modes, i.e., air-purifying, air-supplied and SCBA. This mask is stocked in one size only at Point Lepreau.

The PF for a full-face respirator with TEDA cartridge is 50 for radioiodine and particulates. It provides no protection for tritium, i.e., PF = 1.

A half-face respirator is shown in Figure 9.29. The mask is a half-size face-piece unit with a two-strap head harness. It is available in two designs:



Fig. 9.28. Full-Face Respirator

*) For those of you who thrive on useless information, TEDA stands for "triethylenediamine". The H in TEDA(H) stands for high efficiency.

one with two cartridge receptacles, and the other with a connection for an airline hose. Both designs are available in three sizes.

The PF for a half-face respirator with TEDA cartridge is 50 for radioiodine and particulates. Again, there is no protection for tritium.

You will be tested for respirator fit. Then you'll know whether to use a small, medium, or large. You test your respirator before use by covering the cartridges with your hands, and inhaling. If the respirator collapses on to your face, you're OK.



Fig. 9.29. Half-Face Respirator

Tritium Respirators

The TEDA cartridges will not protect you against tritium. So we use a special tritium cartridge that contains damp charcoal to remove the tritium. These cartridges fit a special tritium half-face respirator that comes in small, medium, and large (Fig. 9.30). The cartridges (one pair per package) are kept at the PESLs along with all the other respiratory gear. They provide protection against tritium for one shift in the Reactor Building, and for four hours continuous use in the Service Building. (The R/B air is much drier, so the cartridges last longer before they saturate.)

The PF of tritium respirators is 3, because although the inhalation route is virtually eliminated, tritiated water vapour will still diffuse through the skin. This means that the intake is reduced to one third.

What if you need protection against tritium and particulates or radioiodine as well? We've got you covered. Fig. 9.31 is a picture of a combined TEDA plus tritium cartridge. These screw into the tritium respirator. They aren't used that often, because most people would use an air-supplied respirator instead.

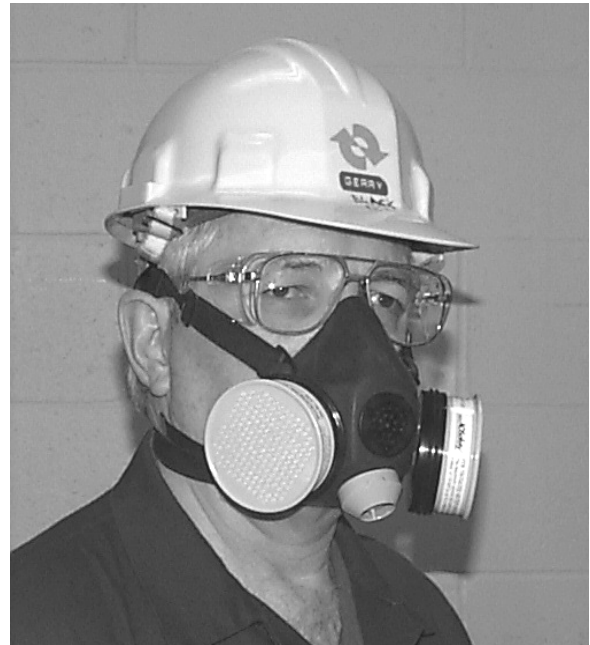

Fig. 9.30. Tritium Respirator



Fig. 9.31. TEDA + Tritium Cartridge

The major limitation of all our air-purifying respirators is that they only remove certain contaminants from the air. They must **never** be used in atmospheres that are deficient in oxygen (fire-fighting, for example). In general, air-purifying respirators are used if mobility is needed. Otherwise, it is usually better to wear an air-supplied respirator or hood.

Air-Supplied Respirators

These may seem like a modern invention, but they were first developed in the 18th century and were in commercial use by the 19th.

Air-supplied respirators, called air masks, use pressurised air from an external source supplied to the face-piece. The source of air is the same Breathing Air System that feeds the plastic suits. An airline connected between the air mask and an air header supplies continuous air flow to the face-piece. This maintains the face-piece at a positive pressure, and keeps the contaminants out when you inhale.

Both full-face and half-face masks may be used with airlines; both require modifications to the inlet receptacle. If you wear glasses or have a beard, you must wear the disposable hood and Ram's Horn combo shown below. That gives you the same PF as an air mask.



Fig. 9.32. Rick MacDonald modelling the Ram's Horn (at left) with Disposable Hood (at right)

The Ram's Horn is positioned high on your neck to give good air flow in the hood, and to stop the visor from fogging. As with the plastic suit, the hood is mounted on the hard hat with a chin-strap to stop the hood blowing off your head.

You should wrap a length of duct tape around your waist to hold the shirt portion of the hood close to the body. Most of the air then leaves the hood via the sleeves and stops contamination getting in there. The PF for the disposable hood and Ram's Horn combination is 100 or better for particulates and radioiodine, and 3 for tritium.

We recommend that you wear the communications headsets otherwise you won't hear messages, because the Ram's Horn is pretty loud (around 80 dB).

One problem with air masks or air-supplied hoods is that you are restricted to an area dictated by the length of the airline (about 15 m — even young workers can be plagued by a receding airline). Also, should the air supply fail (loss of system air, kinked airline, and header disconnection), you will have no protection. For this reason, you must **never** use an air mask in IDLH atmospheres.

Self-Contained Breathing Apparatus

For dangerous atmospheres we use SCBA respirators fed from their own supply of air. They are the only form of respiratory protection approved for fire-fighting at Point Lepreau.

In a SCBA, exhaled breath is exhausted from the face-piece through a check valve to the ambient atmosphere and is replaced by stored air. The Scott Air Pak (don't blame me, that's how they spell it) is an open circuit SCBA. It is of the "pressure demand" type; this means that a very slight positive pressure is maintained inside the face-piece to provide a high degree of protection. This is the only type of SCBA we have at PLGS.

The advantages of SCBAs are that they provide mobility and excellent protection. The disadvantages are that the air supply is limited (about 30 minutes for a Scott Air Pak) and they can be awkward to wear in confined spaces. Also, they are quite heavy — just ask Roger Steed. Figure 9.33 shows Frank Whitenect wearing SCBA.



Fig. 9.33. SCBA

Suggested Protection Factors

For air-purifying respirators intended to protect against particulates, gases and vapours other than tritium, we suggest PFs of 10 for half-face masks and 50 for full-face masks. Whether a full or half-face mask gives a better seal depends entirely on the shape of your face. This is why we "fit test" employees to find out which masks fits them best.

For air-supplied respirators a range of protection factors might apply, depending on how you adjust the air flow. If the air flow is only enough for providing inhalation needs, it is of no more benefit than an air-purifying type. If the air flow is sufficient to keep the face-piece at a positive pressure, it is difficult for contaminants to enter (even with a less than perfect seal), and the PFs should be 100 or more.

"Pressure Demand" air packs give PFs equal to 10,000 or better for particulates and radioiodines, but for tritium you are still limited to a PF of 3.

TABLE 9.2. PROTECTION FACTORS

Respirator Type	Tritium	Particulates	Gases and Vapours
<i>Air-Purifying</i>			
Dust Mask	NP*	5	NP
Half-Face (TEDA)	NP	10	10
Full-Face (TEDA)	NP	50	50
Tritium Cartridge	3	NP	NP
<i>Air Supplied</i>			
Plastic Suit	100+	100+	100+
Disp. Hood	3	100+	100+
Half-Face	3	10 to 100+	10 to 100+
Full-Face	3	50 to 100+	50 to 100+
SCBA	3	10,000	10,000
*) NP means No Protection; 100+ means a PF up to 1000 may be obtainable under ideal conditions.			

I said before that our plastic suit can deliver a PF of 1000 under ideal conditions. If you use it properly, you should not do worse than 100 in practical use. Plastics protection against particulates and radioiodine should be higher than for tritium, because for them the skin absorption route does not exist. For the sake of simplicity, we assume that the same PF of at least 100 applies throughout.

Now you have to remember this:

Respirators SHOULD be worn if airborne contamination exceeds 10 $\mu\text{Sv/h}$, or if the anticipated committed dose exceeds 50 $\mu\text{Sv/h}$.

Respirators MUST be worn if airborne contamination exceeds 50 $\mu\text{Sv/h}$.

Respiratory Hazards

The respiratory hazards found at Point Lepreau can be classified as radiation hazards (i.e., air-borne contamination) or conventional hazards. Mixtures of both may also occur. Each hazard has certain properties you need to consider when selecting suitable protection.

RADIATION HAZARDS

Tritiated Water Vapour
Radioiodine Vapour
Radioactive Particulates
Radioactive Noble Gases

CONVENTIONAL HAZARDS

Oxygen Deficiency
Chlorine Gas
Hydrocarbon Vapours
Smoke and Toxic Gases
Dusts and Welding Fumes

Tritium

The best protection you will achieve with air-supplied or tritium cartridge respirators is only a factor of 3. The only way to reduce the skin absorption is by wearing plastics. You must wear plastics for work in atmospheres containing more than 500 $\mu\text{Sv/h}$, for work involving moderator water, for PHT spills greater than 1 L, and for anticipated doses greater than 500 μSv .

Radioiodine

Radioiodine passes through conventional filters. TEDA impregnated charcoal filters are needed to remove it.

Particulates

All respirators, except the tritium cartridge respirator, used for radiation work at Point Lepreau give reasonable protection against inhalation of particulates. However, for work in high concentrations of particulates, e.g., in the Spent Fuel Discharge Bay after the discharge of defective fuel, it is best to wear a plastic suit. This will give good respiratory protection, while at the same time preventing skin and hair contamination. The same applies for radioiodine.

Noble Gases

Noble gases are not an internal hazard, because any noble gases you inhale will be exhaled again. It is possible for trace amounts to dissolve in the blood, but such noble gas concentrations in the blood give only a negligible dose. The internal exposure from dissolved noble gases amounts to about one thousandth of the external exposure. So no respiratory protection is needed.

Oxygen Deficiency

Oxygen deficient atmospheres are a life-threatening hazard. The **only** protection that may be worn is Self-Contained Breathing Apparatus.

Chlorine Gas

Chlorine gas is a life-threatening hazard. It can also react with both body perspiration and moisture in the air to form a corrosive acid. At 1 ppm you must wear a SCBA, and in emergency concentrations of 1% or more (e.g., during a chlorine leak), a special chemical suit must also be worn to prevent skin contact.

Smoke and Toxic Gases

Both of these hazards are life threatening. SCBA is the **only** appropriate form of respiratory protection. At Point Lepreau you are likely to encounter these hazards only when fire-fighting. Do not enter atmospheres dangerous to life or health unless you are wearing a functional SCBA.

Hydrocarbon Vapours, Dusts and Welding Fumes

The TEDA cartridge has a high efficiency filter and is therefore effective in removing dusts, fumes and mists from the air. The cartridge is not as good at removing hydrocarbon vapours, although it will provide some protection against low concentrations of organic vapours. Canisters that have been specifically designed to give protection against organic vapours are available from Radiation Control. These canisters are used with the full-face mask.

If there is any doubt about the ability of the normal TEDA cartridges to remove a particular contaminant from the air, and if the contaminant is not IDLH, use an air-supplied respirator or hood. Better still, if you have any questions or problems regarding the selection or use of respiratory equipment, ask the lads in Radiation Control for advice. They know their stuff.

Respirator Fit Testing

A respirator fit test checks that you receive an effective and comfortable fit when wearing respirators. This test is done for all of you who need to wear respirators at Point Lepreau. The test consists of wearing respirators hooked up to a special monitor. While wearing each respirator, you do a short series of exercises. Face-piece leakage during these exercises is recorded.

In this way, you'll find out which respirator provides the most comfortable fit and what PF you achieve when you are wearing it. Respirator fit can be affected by:

- a) A change in body weight of six kg or more.
- b) Dental surgery involving the removal of three or more teeth.
- c) Growth of hair or stubble near the respirator seal.
- d) Any change in facial conditions.

Respirator Maintenance

After use, respiratory equipment is washed, monitored, inspected, repaired or serviced as necessary, disinfected, put in clean plastic bags, and is restocked at the PESLs. Service Maintenance does this job, and they do it well.

TABLE 9.3. SUMMARY OF RESPIRATORY PROTECTION

<i>Respirator Type</i>	<i>Protects Against</i>	<i>Limitations</i>	<i>Comments</i>
Air-Purifying	Low levels of tritium, particulates, radioiodines, dusts & fumes, hydrocarbon vapours.	Not to be used in IDLH atmospheres, not to be worn with beards.	You must select the correct cartridge for each hazard.
Air-Supplied Respirator or Hood	Same as above.	Non-IDLH.	Limited mobility.
Plastics	Higher levels of above.	Non-IDLH	Limited mobility, potential for heat stress.
SCBA	Life-threatening hazards (IDLH).	30 minute air supply, not to be worn with beards or glasses.	Used for emergencies and training only.

Note: TEDA(H) cartridges provide no protection against tritium atmospheres. Tritium cartridge and air-supplied respirators, as well as SCBA, have a protection factor of 3 for tritium.

DECONTAMINATION

During Point Lepreau's operation, it is inevitable that many items of equipment, and also tools, work areas, clothing, and even people will become contaminated — that is, a layer of radioactive material becomes attached to surfaces. This surface contamination must be removed. Decontamination serves two purposes:

1. It eliminates the health hazard of internal and external radiation. Loose contamination must be cleaned up.
2. It salvages equipment that, because of the surface contamination on it, would otherwise be sent to active waste rather than for repair.

In the remainder of this chapter, we will discuss the decontamination methods that you can use and the principles of protection that you will follow in using these methods.

Decontamination Methods

The methods for removal of radioactive contamination are similar to methods used to remove ordinary dirt, but the required degree of cleanliness is much greater. Small amounts of contamination, which would be completely negligible from an ordinary cleanliness aspect, may still present a radiation hazard.

Apart from this distinction, the processes used in decontamination are the same as those used for industrial cleaning. Namely, soil or contamination is removed by chemicals such as detergents, or by physically removing the contaminated surface (e.g., by abrasives).

Contamination on the surface of an object may be attached either loosely or firmly, hence the terms loose and fixed. The contamination may be attached chemically or it may be mechanically trapped in cracks or small holes. The cleaning process must break the union or bond between the surface and the contamination. The contaminant must then be removed from the surface and prevented from re-attaching itself to it.

Chemical Decontamination

The best method for most decontamination operations is to clean with water to which one or more suitable chemical cleaning agents have been added.

Detergents

The cleaning agents must be capable of removing the contamination from the contaminated surface and then holding it in solution without letting it re-attach itself. Various chemical compounds are available for special purposes, but generally speaking, commercial detergents work just as well and are usually a lot cheaper, too.

Chemical Solvents

Chemical solvents are normally used only after efforts with detergent solutions have failed. Varsol, trichloroethylene (used in dry-cleaning), and paint removers have all been used successfully. The problem is that they are often toxic and flammable.

Acids

Application of acids to surfaces is an excellent way of removing contamination, but it has limited usefulness because of the damage that may result due to the corrosive action of the acids. Use acids with caution.

Alkalis

Alkalis such as caustic soda solutions are occasionally used as decontamination agents. These are particularly useful for washing rubber articles such as gloves or rubbers.

Physical Decontamination

So far we have talked of chemical methods of decontamination. Although the chemical solution (e.g., detergent solution) may be scrubbed or wiped over the surfaces, the decontamination action is really provided by the chemicals. There are decontamination methods in which the outer layer of the contaminated surface is removed by physical force. Such methods are effective; but they are somewhat crude and destructive, and it may not be possible to use them on delicate objects. Some techniques are:

1. Scrubbing with abrasive powder like Ajax or with steel wool.
2. Sandblasting.
3. Cleaning with high-pressure steam jets or ice chips.
4. Vacuum cleaning.
5. Ultrasonic cleaning.

These methods have particular applications. A method useful for certain objects may be unsuitable for others. It is beyond the scope of this course to go into the fine details of these methods — this is covered in the Decontamination Procedures. However, here are a few clues.

Scrubbing and Sand-Blasting

Remember that if you are removing contamination, the waste suds or sand will be contaminated and must be treated as radioactive waste.

Steam Cleaning and Ice Chips

Steam cleaning is usually used on large decontamination jobs. One advantage is that the residue (condensed steam) has a much smaller volume than would be left if high pressure hot water had been used instead. Therefore it is easier to dispose of as active waste.

We also have an ice-blast machine (mentioned on page 179). It requires large volumes of high-pressure air. The ice impacts like a sand blaster and then a melting and washing effect follows. The contaminated melted water has to be collected, so the ice blaster is usually used in a room whose walls can be easily decontaminated. We use it for primary-side PHT boiler cleaning, fuel handling equipment, and pump impellers.

Vacuum Cleaning

In principle, this is the same method as is used to clean a carpet. However, once more a word of warning: the dust in the dust bag will be radioactive. It may be very highly radioactive (hundreds of mGy/h) after removing high level surface contamination. Be careful when using vacuum cleaners; they may create radiation and airborne hazards.

Ultrasonic Cleaning

This involves the use of a special cleaning tank and ultrasonic (i.e., very high frequency) sound. The sound waves bombard the surface of dirty equipment and tear the dirt from it. The cleaning tank is filled with a suitable decontamination solution, to prevent re-deposition of the contamination on the equipment.

All these techniques are useful but the most common ones you will use are the good old standbys — washing with detergent by hand and scrubbing.

Some General Principles

1. Assess the hazard. Make direct (contamination meter) and indirect (smears) measurements. If your contamination meter goes off-scale, use a gamma survey meter and a beta survey meter to make sure that the equipment isn't "too hot to handle".
2. Follow the decontamination procedures. The station has adequate facilities for normal decontamination work. The procedures describe in detail the approved methods you'll use for most types of decontamination work.
3. Protect the area. Set up a Rubber Area as needed.
4. Protect yourself. Wear appropriate protective clothing and respiratory equipment.

5. Assess the dose. If you anticipate exposure to your hands, wear extremity TLDs.
6. Prevent the spread of contamination. Handle all waste as radioactive waste.
7. Wet decontamination methods are better than dry methods because they are less likely to cause an airborne hazard.
8. Try mild decontamination methods first before you resort to physical methods that may cause damage.
9. You should use chemical solvents only in approved areas. Be careful and use approved procedures.
10. Make measurements. You can gauge your success only with direct and indirect measurements.
11. Clean up when you are finished.

Decontamination Areas

There are five areas in Point Lepreau G.S. where regular decontamination is done. They are:

<i>Change Room</i>	decontamination of people
<i>Cotton Laundry</i>	decontamination of fabric clothing
<i>Plastics Laundry</i>	decontamination of plastic clothing and respirators
<i>Decontamination Centre</i>	decontamination of shoes, small equipment, tools, and D ₂ O drums
<i>Spent Fuel Reception Bay</i>	we might occasionally have to decontaminate a spent fuel flask or similar sized vessel: this would be done here.

Decontamination of Equipment

Equipment should normally be decontaminated soon after it is removed from the active area. If it is decided to delay decontamination (e.g., to allow decay), the item should be sealed in plastic, labelled conspicuously and stored in an appropriate location such as the Active Storage Room.

Small equipment and tools will be decontaminated in the Decontamination Centre, where proper facilities and fume hoods are provided.

Large equipment that is too difficult to move can be decontaminated in place. If high levels of contamination are present, a plastic tent should be assembled around the equipment and temporary ventilation should be provided using a portable filtration unit and flexible ducting. During decontamination, wear the appropriate protective clothing (e.g., dispos over Browns, rubber gloves, respirator, etc.).

Figure 9.34 shows the layout of the Decontamination Centre at Point Lepreau. It includes:

1. Sinks for washing, scrubbing, rinsing, etc.
2. Soaking tanks for steeping in detergent solutions.
3. Steam cleaning equipment.
4. Ultrasonic cleaning equipment.
5. Monitoring instruments.

In cases where surface contamination can't be removed from equipment by normal non-destructive decontamination methods, it may be necessary to remove the contaminated outer surface (provided, of course, that this doesn't make the equipment fubar).

The extent to which equipment must be decontaminated depends on the amount of handling it will receive and where it is to be used. If it is to be returned to an active system without much subsequent handling, it may be alright to decontaminate it to the point where it can be safely used in the system without undue handling precautions.

It is OK for tools to be decontaminated to the same level as protective clothing (5 CCLs fixed, no loose), provided that they are then painted yellow to ensure that they do not find their way into contamination-free zones.

Decontamination of Working Areas

What you do depends on what has happened. Generally, decontamination proceeds in stages: remove the gross contamination, and then remove the remaining activity to the degree necessary. Let's take the example of the floors in the Fuelling Machine Vaults. These are cleaned at the start of each annual outage and there are often hundreds of CCLs on the floor near the reactor face (mainly Zr-95 and Nb-95 from PHT water spilled from the Fuelling Machines).

Generally, the approach would be as follows:

1. Assemble all the necessary cleaning equipment outside the area. (e.g., carboys of water, mops, buckets, garbage bags, rubbers, gloves, dispos, Masslinn mops, etc.)
2. Set up rubber stations at vault entrances and signpost all access points.
3. Wash the floor directly beneath the reactor face where the activity is concentrated. Wet mopping with warm water is the quickest and most effective method of removing loose contamination from floors. Mop the area once or twice. Change mop heads and water often to avoid cross-contamination. Once the floor is dry, use a Masslinn mop to check the area that has been washed.

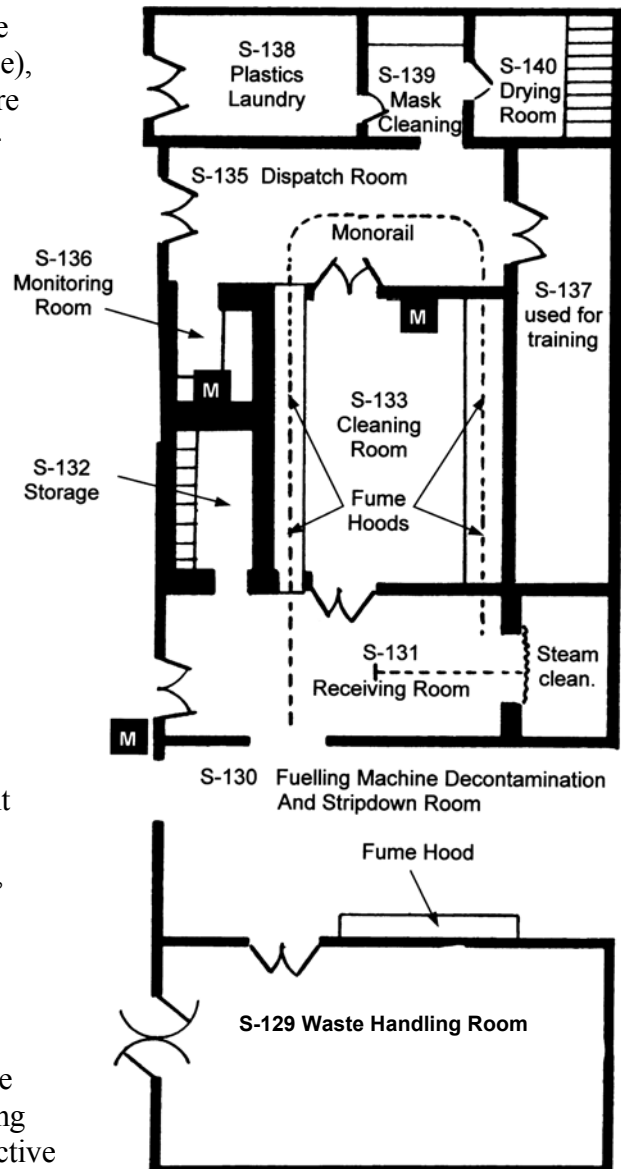

Fig. 9.34. Decontam Centre at PLGS

4. Less contaminated nearby areas may also be mopped with a Masslinn mop. Check the Masslinn cloths in a low background area.
5. If the floor cannot be completely cleaned, or if further maintenance activities may spread contamination (as is the case here), lay down canvas over the area and signpost accordingly.

You would then double-bag all active waste and contaminated items, and put the contaminated water into the active sump specified on the Work Plan.

Heavy Water Spills

Large spills of heavy water do happen. If you find one, back off if you are not wearing plastics, and then call the Control Room. Moderator D₂O can produce dose rates as high as **hundreds of mSv** right above the spill. Radiation protection Procedure DC-17 devotes six pages to work with Moderator/PHT water. This is very serious stuff and our biggest radiation risk by far.

If you are not in plastics already, you and those sent to help must get them on. The objective is to minimise dose during cleanup. This can't be done simply by minimising the time for the cleanup; adequate protection is essential. Do not participate in the cleanup if you may have received significant exposure during the spill. If you got wet during the initial spill, you should shower as soon as possible. The heavy water should then be recovered as soon as possible because, as you know, it is very expensive and will down-grade quickly. Also, tritium levels in the area will increase rapidly.

If the spill is large, you would use a "Vac-U-Max" (a nuclear-grade shop-vac), mops, and sponges. After you have finished, all absorbent material should be sealed in polythene bags for disposal. When all the heavy water has been collected, it will almost always be necessary to wash down the surface in order to remove residual activity, both tritium and beta-gamma. Finally, a contamination survey of the area would be done. We have an exercise in the Application Course, where you will practise cleaning up a spill.

Decontamination of Clothing

Personal clothing should never become contaminated except by accident. If your street clothes become contaminated, sticking masking tape over the affected area and then removing the tape is sometimes effective. If necessary, scrubbing the affected area with a detergent solution is usually successful. If not, we can run them through the laundry.

If that doesn't work, your clothes will join all the other garbage in active waste. The Shiftie would authorise the issue of a coverall so that you won't have to streak home. There will be no compensation for this, unless you can prove that an amazing set of coincidental circumstances absolved you from all blame. I wish you luck.

Protective clothing (i.e., Browns) for radioactive work becomes contaminated routinely. It is decontaminated in the laundry (next to the Change Room) designed for this purpose. The wash procedure is quite elaborate and may involve many wash cycles with different combinations of

cleaning agents. After drying, the clothing is monitored and if fixed contamination is below acceptable levels (5 CCLs), it is returned for use. Rubbers and plastic clothing are washed in a similar manner in the Plastics Laundry, but with different washers and drying procedures.

You should segregate protective clothing on the basis of the degree of contamination. Before you throw your clothing into the dirty clothing cribs, you should monitor it to see if it is basically clean or contaminated. We have bins for "clean" and "dirty" (i.e., contaminated) used clothing, so that we can launder them separately to reduce the chances of cross contamination in the wash. You'd do the same at home: you don't wash the greasy coveralls you wore when stripping down your engine together with your lady's negligee, do you? At least not more than once.

Decontamination of Skin

When you're doing radioactive work, you sometimes get contamination on your skin, especially on your hands. Sometimes, your face and hair also gets crapped up.

For hand contamination, a good wash with soap and warm water is generally all that's needed. (Hot water opens the pores and you might drive the stuff in deeper. Cold water closes them, and you might not get it out.) This should remove all loose contamination and reduce the residual contamination to below 1 CCL. If contamination is under your fingernails, a soft bristle brush should be used with soap and warm water. You should be careful not to scrub or rub the skin to the point where it reddens, because then there is a risk of the contamination entering your blood stream directly.

If soap and water don't do it for you, then you use a chemical hand cleanser you'll find in the Change Room. This skin cleanser contains small plastic granules to help loosen contamination. This step may be repeated once, but only if there is no evidence of skin damage from the decontamination. Remember to dry your skin completely before re-monitoring, since betas are easily absorbed in water.

If the contamination level is now below 5 CCLs, it is usually better to stop the decontamination rather than risk skin abrasion, severe removal of skin oils, and possibly entry of the contamination into your body. If you cannot reduce contamination below 5 CCLs, you should seek advice from Health Physics. Remember, it is important that you stop decontamination immediately if the skin starts reddening. It is much better to live with the contamination on your skin than risk getting it into your body.

If your skin is still contaminated at a level of between 1 and 5 CCLs, you need Shift Supervisor approval to leave the station. Over 5 CCLs needs approval from Health Physics.

For decontamination of the face and hair, showering once or twice is your best bet. Keep your mouth and eyes shut while doing this. If you have minor cuts or scratches you should be very sure that:

- (a) they are covered with surgical dressings, and
- (b) you do not work in areas where you are likely to contaminate yourself.

Wow! That's the end of this chapter. I hope I didn't type too fast for you?

SUMMARY

Contamination can occur in solid, liquid and gaseous forms. Good contamination control consists of monitoring, containment, and decontamination.

Contamination on surfaces is classified as fixed or loose; it is monitored directly with friskers, and indirectly with smears and Masslinn mops. Review the Contamination Control Limits on page 271. 1 CCL of fixed contamination corresponds to about 15 cps on a pancake frisker. Any loose contamination should be cleaned up immediately. If that isn't practicable, it must be contained within a Rubber Area or even a Rubber Change Area.

Airborne contamination can exist as particulates, noble gases, tritium or radioiodines. Particulates and radioiodines are measured with spot samplers; the DAC for unidentified particulates is 200 Bq/m^3 . Noble gases can be recognised by uniform beta and gamma fields in an area. Portable ion chamber monitors and bubblers are used to measure tritium.

Respirators protect you from airborne contamination, but only if you wear them. You should wear a respirator for committed dose rates greater than $10 \mu\text{Sv}$. You must wear one for committed dose rates greater than $50 \mu\text{Sv/h}$ or for committed doses greater than $50 \mu\text{Sv}$. Know the protection factors on page 315. The uses and limitations of respirators are summarised on page 318.

For tritium atmospheres of $500 \mu\text{Sv/h}$ or more, for anticipated doses greater than $500 \mu\text{Sv}$, for any work with moderator water, and for cleaning up PHT spills of more than 1 L, you must wear a plastic suit. With proper use, you should get a PF of 100 or better.

Rigid procedural controls help to prevent the spread of contamination. Examples are:

- (a) establishing permanent contamination control zones,*
- (b) establishing temporary contamination control zones called Rubber Areas with special protective clothing requirements,*
- (c) channelling workers in radiation area clothing (Browns) through special change rooms, and keeping this clothing separate from street clothes.*

The ventilation systems in the station are designed to prevent the spread of contamination (as well as providing clean air for us to breathe). Portable ventilation systems can be set up for localised dirty jobs.

Washing or scrubbing with warm water and detergent normally cleans contaminated surfaces. In extreme cases, steam cleaning or even stripping the surface may be necessary. Vacuum cleaners can be effective, but watch for external radiation hazards from the filters. When decontaminating a large area, it is usually best to start from the outside and work your way to the middle.

Fixed contamination on skin should be kept below 1 CCL. Stop decontamination immediately if your skin starts to redden. If the remaining contamination is above 1 CCL, consult the Shift Supervisor or Health Physics.

Courtesy of the Darwin Site:

The average cost of rehabilitating a seal after the Exxon Valdez oil spill in Alaska was \$80,000. At a special ceremony, two of the most expensively saved animals were released back into the wild amid cheers and applause from onlookers. A minute later they were both eaten by a killer whale.

PROBLEMS

1. Explain the difference between activation and contamination.
2. What is the maximum allowable level of **loose** beta-gamma contamination (in CCL):
 - (a) in the Zone 2 coffee room?
 - (b) on personal clothing?
 - (c) on the outside of a radioactive material shipping container?
 - (d) in Zone 2 outside a Rubber Area?
 - (e) on body surfaces?
3. What is the maximum permitted level of **fixed** beta-gamma contamination (in CCL):
 - (a) on personal clothing?
 - (b) on protective clothing?
 - (c) on respirators?
 - (d) on materials transferred to Zone 1 unconditionally?
 - (e) on body surfaces?
 - (f) on plastic suits?
4. The main disadvantage of the direct method of surface contamination measurement is that
 - (a) it can't be used on rough surfaces,
 - (b) it can't measure tritium,
 - (c) it can't detect loose contamination,
 - (d) it can't be used in high beta/gamma background areas,
 - (e) it suffers from dead time losses at very high count rates,
 - (f) it responds to very high airborne tritium concentrations.
5. You have been promoted to Assistant EI&C Maintainer. Your first mission is to adjust the alarm set point (cps) on our laundry monitor shown at right. You have to set it so that Browns contaminated to the permissible level for fixed contamination are just going to trigger the alarm. The detector is rectangular, 16 cm long and 8 cm wide. The lead shielding around the detector results in a steady background count rate of about 30 cps. The detector efficiency is around 15%. What should the alarm set point be?
6. How can the Herfurth Full-Body Monitors at the bridge to the Admin Building distinguish between fixed and loose contamination?
7. Why do we not monitor respirators and protective clothing for loose contamination?
8. How do you avoid contaminating your hands when taking smears?



Fig. 9.35. Laundry Monitor

9. You are doing a Masslinn Mop survey of the Zone 2 Coffee Shop floor. What kind of instrument would you use to check whether any loose contamination is picked up?
10. A photographer from Head Office is taking some pictures in the F/M Maintenance Area. When she is finished, you frisk her camera (a Pentax 6x7 belonging to NB Power), and you find traces of contamination on the base. You take a smear of the whole base area of 100 cm², and count the smear in a smear counter. Background count was 102 cpm and smear count was 258 cpm. Assuming that 10% of the loose contamination was picked up by the smear, work out whether the camera can leave the station or not.
11. You have to draw a sketch of some equipment that has been modified. It is located permanently in the Spent Fuel Discharge Bay, an area that is normally heavily contaminated with loose β,γ activity. It is a permanent Rubber Area. Explain how you would propose to get an uncontaminated diagram to Zone 1.
12. Why should you check hot smears with a gamma survey meter first? You do this, and get 20 $\mu\text{Sv/h}$. What now?
13. Can a CAM measure particulate concentration in the air it is monitoring?
14. What do you do if a CAM alarms in the area in which you are working?
15. Why do we not take air samples for noble gases?
16. You have taken an air sample in the Boiler Room in the Reactor Building. You count the background in the scaler to be 47 cpm. You then count the particulate filter and get 8063 counts in one minute. You use the graphs posted at the counting station (Fig. 9.12) to obtain how many $\mu\text{Sv/h}$ of particulate activity?
17. You then remove the particulate filter and recount the background. This time you get 49 cpm. You insert the charcoal cartridge, count for one minute and get 53 counts. You use the graphs posted at the counting station (shown at right) to obtain how many $\mu\text{Sv/h}$ of radioiodine activity?
18. If an AATM alarms on high radiation level in the area where you are working, you should do all of the following. Indicate the three actions you should take first:
- (a) leave the area (d) call the Control Room Operator
 (b) give a urine sample (e) check that everyone else has left
 (c) signpost the area (f) acknowledge the alarm

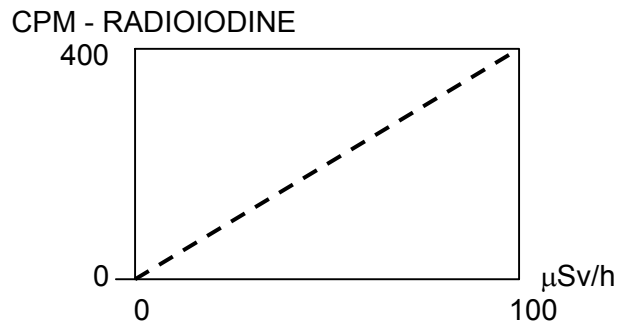

19. A leaking valve has been discovered in the PHT Auxiliaries Room where the general gamma field is about $150 \mu\text{Sv/h}$. You have been asked to do a tritium survey of the room for the repair job. The Scintrex read about 1 mSv/h at the entrance to the room. You took a bubbler sample near the valve and got $500 \mu\text{Sv/h}$.
- Which reading is likely to be correct?
 - Why?
 - What could you have done to improve the incorrect reading?
20. You used a bubbler to measure the tritium concentration in the Boiler Room air. You follow the procedure outlined on page 289 – 290, and you get an answer of $20 \mu\text{Sv/h}$. What would the true value have been if
- The bubbler ran for 10 minutes instead of 5?
 - If you used 200 mL of water instead of 100 mL?
 - If you used 2 mL of sample water instead of 1 mL?
 - If the efficiency of the counter were only half of what it is supposed to be?
 - We assume that the bubbler traps all of the tritium in the air bubbling through it. What would be an easy way of checking this?
21. The tritium concentration in a room with a heavy water leak does not depend on which one of the following:
- The concentration of tritium in the heavy water.
 - Whether the room is connected to the heavy water recovery dryers.
 - The temperature of the room.
 - The amount of ventilation air flowing through the room.
 - The heavy water leak rate.
 - Whether the walls of the room are painted with water-proof high gloss acrylic paint or water-based latex paint.
 - The size of the room.
22. Briefly explain the zoning system in use at Point Lepreau. Give two example locations for Zone 1, Zone 2, Zone 3, and Unzoned Areas. Explain the rules that apply to the use of Radiation Area Clothing and food/drink in each of these areas.
23. You are dressed in Browns and have been asked to take two pipe wrenches from the Mechanical Maintenance Shop to the Hanson Stream Pumphouse. Describe what you would need to do to comply with all the contamination control requirements.
24. Indicate whether a **Conditional Release Permit** (white), an **Unconditional Release Permit** (yellow), or **No Release Permit** is required by circling C, U, or N for the following conditions:
- Karl is red-qualified and wants to take some computer software on disk from the Radiation Control Office to Head Office.
 - Nancy wants to take a piece of boiler tube from the Station Manager's office to the President at Head Office.

- (c) Steve is orange-qualified and wants to take to the Fredericton HP Lab some tap water samples from the HP Lab at Lepreau.
 - (d) Keith is green-qualified and wants to take a completely clean and decontaminated valve seat from the Decontamination Centre to the STOIC Building for a Show & Tell.
 - (e) Michelle is yellow-qualified and wants to borrow a brand new pair of Radiation Area Coveralls to show at the annual New Brunswick Fashion Show in downtown Dipper Harbour.
 - (f) Allan is a yellow-qualified EI&C Maintainer who has repaired two flow gauges in the R/B and now wants to take his tools back to the EI&C shop.
25. (a) When should you set up a Rubber Area?
(b) When should you set up a Rubber Change Area?
(c) When must you set up a Rubber Change Area?
(d) Will a Rubber Change Area always be within a Rubber Area?
(e) Can you enter a Rubber Area in street clothing?
26. In April 1995, a mechanic set off the Full-Body Monitors at the bridge to the Admin Building. He had been working on ECC valves without wearing gloves. He was asked to wear surgeon's gloves for 20 minutes and then shower. After this no contamination remained. Can you explain why?
27. During the 1993 outage, a contractor employee caused the Portal Monitor to alarm on his way to the Admin Building. A whole-body count in the HP Lab indicated internal contamination (0.52 mSv), mainly from Co-60 and Zr-Nb-95. He had been working in the Boiler Cabinets with a respirator. Do you have any idea how he may have picked up this dose?
28. List (from head to toe) the protective clothing and equipment you would wear when entering a Rubber Area to do some work on a contaminated piece of equipment located there.
29. When monitoring yourself at the Equipment Airlock after leaving the Reactor Building, you find contamination on both feet. What three actions should you take?
30. (a) Under what two circumstances can you wear Dispos over Browns?
(b) Can you wear your Zone 1 safety shoes with Browns?
31. What can (and must) you do to ensure that the ventilation systems at PLGS work as intended?
32. What are the four conditions for which you must wear plastics?
33. Indicate the tritium Protection Factors that apply at PLGS to
- (a) air-supplied plastic suit and hood,
 - (b) tritium respirator with tritium cartridge,
 - (c) air-supplied hood with Ram's Horn
 - (d) plastic suit and hood without air supply.

34. Laurie and Phil cleaned up a moderator spill wearing plastics. A bubbler sample indicated an airborne concentration of 30 mSv/h in the area where they worked. The job took two hours. Bioassay results indicated that Laurie picked up 0.4 mSv and Phil picked up 0.6 mSv from this job.
- What Protection Factor did Laurie achieve?
 - What PF did Phil achieve?
 - Give two reasons that might explain why Phil picked up more dose.
35. You are going to work for two hours in an area that has 2.5 mSv/h of tritium and 1.5 mSv/h of gamma. You are going to wear plastics.
- What will be your total whole-body dose commitment?
 - What are three conventional safety hazards you are exposed to when wearing plastics?
36. You are going to work for 2 hours in an area that has 750 μ Sv/h tritium and 3 mSv/h gamma.
- You wear plastics for the job. What will be your total dose commitment?
 - You think that you could do the job in 20% less time if you wore a tritium respirator instead of plastics. What would your total dose commitment be now?
 - If the second option results in less dose than the first, is this the way to go?
- 37.
- Can you wear a full-face respirator with a beard or glasses?
 - Can you wear a half-face respirator with a beard or glasses?
 - What about if you just need a shave?
- 38.
- Under what condition should you wear a respirator?
 - Under what two conditions must you wear a respirator?
39. For what four circumstances must you wear plastics?
40. What is the only respiratory equipment suitable for IDLH atmospheres?
41. You are taking a copy of this book from the Decontamination Centre to Zone 1. When you frisk it, you find that the outside covers are contaminated. What now?
42. You are entering Zone 1 on your way home when the Full-Body Monitor alarms. The display indicates that your hands are contaminated, recording 100 counts (150 counts = 1 CCL). Can you leave if the contamination on your hands
- is fixed?
 - is loose?
 - If you have 2 CCLs of fixed contamination on your hands and all safe decontamination methods have been tried, whose permission is required before you may leave?
 - What about 7 CCLs?
43. When not in use, air lines should be disconnected from the air header. Why?

